

MASONRY DESIGN AND DETAILING

FIFTH EDITION

for Architects
and Contractors



CHRISTINE BEALL, NCARB, CCS

Now fully updated, here's today's only complete single-source guide to designing, specifying, and building in masonry!

MASONRY DESIGN AND DETAILING

FOR ARCHITECTS, ENGINEERS,
AND CONTRACTORS

Reflecting vital changes in the Uniform Building Code, the MSJC Code, and ASTM standards, as well as the latest insight into evolving materials, systems, and technology, the new Fourth Edition of *Masonry Design and Detailing* is written for practicing professionals who are seeking a current, hands-on guide to quality masonry that is neither an esoteric structural engineering manual nor an overly simplistic do-it-yourself book.

Every important aspect of masonry is illuminated in practical terms, including all types of wall systems, unit and mortar selection, component detailing, material specs, quality control testing, building code compliance, aesthetic variables, and installation requirements. The new *Fourth Edition* offers new information on:

- The "how" and "why" of wall cracking and moisture penetration—and how to avoid these problems
- Mortar and grout mixtures and their uses
- New flashing materials, new seismic anchors, interlocking CMU retaining wall systems, innovative flashing blocks, and new accessories
- Environmental topics such as recycling and sustainability
- ASTM standards and tests, construction submittals, and specs for historic restoration
- Uniform Building Code and MSJC Masonry Code requirements

Enhanced by more than 400 illustrations, the *Fourth Edition* gives architects, engineers, specifiers, and masonry contractors the principles and practical know-how they need to ensure quality, performance, and durability in masonry construction.

Cover Design: Richard Adelson

Visit us on the World Wide Web at
www.books.mcgraw-hill.com

McGraw-Hill

A Division of The McGraw-Hill Companies



MASONRY DESIGN AND DETAILING

This page intentionally left blank.

MASONRY DESIGN AND DETAILING

For Architects and Contractors


CHRISTINE BEALL, NCARB, CCS

Fifth Edition

McGraw-Hill

New York Chicago San Francisco Lisbon London Madrid
Mexico City Milan New Delhi San Juan Seoul
Singapore Sydney Toronto

This page intentionally left blank.



Copyright © 2004, 1997, 1993, 1987 by Christine Beall. All rights reserved. Manufactured in the United States of America. Except as permitted under the United States Copyright Act of 1976, no part of this publication may be reproduced or distributed in any form or by any means, or stored in a database or retrieval system, without the prior written permission of the publisher.

0-07-143339-2

The material in this eBook also appears in the print version of this title: 0-07-137734-4.

All trademarks are trademarks of their respective owners. Rather than put a trademark symbol after every occurrence of a trademarked name, we use names in an editorial fashion only, and to the benefit of the trademark owner, with no intention of infringement of the trademark. Where such designations appear in this book, they have been printed with initial caps.

McGraw-Hill eBooks are available at special quantity discounts to use as premiums and sales promotions, or for use in corporate training programs. For more information, please contact George Hoare, Special Sales, at george_hoare@mcgraw-hill.com or (212) 904-4069.

TERMS OF USE

This is a copyrighted work and The McGraw-Hill Companies, Inc. (“McGraw-Hill”) and its licensors reserve all rights in and to the work. Use of this work is subject to these terms. Except as permitted under the Copyright Act of 1976 and the right to store and retrieve one copy of the work, you may not decompile, disassemble, reverse engineer, reproduce, modify, create derivative works based upon, transmit, distribute, disseminate, sell, publish or sublicense the work or any part of it without McGraw-Hill’s prior consent. You may use the work for your own noncommercial and personal use; any other use of the work is strictly prohibited. Your right to use the work may be terminated if you fail to comply with these terms.

THE WORK IS PROVIDED “AS IS”. MCGRAW-HILL AND ITS LICENSORS MAKE NO GUARANTEES OR WARRANTIES AS TO THE ACCURACY, ADEQUACY OR COMPLETENESS OF OR RESULTS TO BE OBTAINED FROM USING THE WORK, INCLUDING ANY INFORMATION THAT CAN BE ACCESSED THROUGH THE WORK VIA HYPERLINK OR OTHERWISE, AND EXPRESSLY DISCLAIM ANY WARRANTY, EXPRESS OR IMPLIED, INCLUDING BUT NOT LIMITED TO IMPLIED WARRANTIES OF MERCHANTABILITY OR FITNESS FOR A PARTICULAR PURPOSE. McGraw-Hill and its licensors do not warrant or guarantee that the functions contained in the work will meet your requirements or that its operation will be uninterrupted or error free. Neither McGraw-Hill nor its licensors shall be liable to you or anyone else for any inaccuracy, error or omission, regardless of cause, in the work or for any damages resulting therefrom. McGraw-Hill has no responsibility for the content of any information accessed through the work. Under no circumstances shall McGraw-Hill and/or its licensors be liable for any indirect, incidental, special, punitive, consequential or similar damages that result from the use of or inability to use the work, even if any of them has been advised of the possibility of such damages. This limitation of liability shall apply to any claim or cause whatsoever whether such claim or cause arises in contract, tort or otherwise.

DOI: 10.1036/0071433392

To Dee, Puppy, Squirt, Peanut, and Pinky

CONTENTS

Preface to Fifth Edition xix

Preface to Fourth Edition xxi

Preface to Third Edition xxiii

Preface to Second Edition xxv

PART I INTRODUCTION

1	HISTORY AND DEVELOPMENT OF MASONRY TECHNOLOGY	3
1.1	Development	3
1.2	Decline	5
1.3	Revival	5
1.4	Contemporary Masonry	8
1.5	Common Concerns	8
2	RAW MATERIALS AND MANUFACTURING PROCESSES	11
2.1	Clay Masonry	11
2.1.1	Clay Composition	12
2.1.2	Clay Types	12
2.1.3	Material Preparation	13
2.1.4	Manufacturing	13
2.1.5	Forming	13

- 2.1.6 *Drying* 16
- 2.1.7 *Glazing* 17
- 2.1.8 *Burning* 18
- 2.1.9 *Drawing and Storage* 20

- 2.2 Concrete Masonry 20**
 - 2.2.1 *Aggregates* 20
 - 2.2.2 *Cements* 21
 - 2.2.3 *Admixtures* 22
 - 2.2.4 *Manufacturing* 22
 - 2.2.5 *Material Preparation* 22
 - 2.2.6 *Forming* 23
 - 2.2.7 *Curing* 23
 - 2.2.8 *Surface Treatment* 25
 - 2.2.9 *Cubing and Storage* 26

- 2.3 Mortar and Grout Materials 26**
 - 2.3.1 *Cements* 26
 - 2.3.2 *Lime* 27
 - 2.3.3 *Masonry Cements and Mortar Cements* 29
 - 2.3.4 *Sand* 30
 - 2.3.5 *Water* 32
 - 2.3.6 *Mortar Admixtures* 32
 - 2.3.7 *Mortar Colors* 35
 - 2.3.8 *Grout Admixtures* 36

- 2.4 Environmental Impact 37**
 - 2.4.1 *Resource Management, Recycled Content, and Embodied Energy* 38
 - 2.4.2 *Construction Site Operations* 39
 - 2.4.3 *Indoor Air Quality/Building Ecology* 39

PART 2 MASONRY PRODUCTS AND ACCESSORIES

3 CLAY AND CERAMIC PRODUCTS

43

- 3.1 Brick 43**
 - 3.1.1 *Sizes and Shapes* 49
 - 3.1.2 *Hollow Brick* 53
 - 3.1.3 *Special-Purpose Bricks* 54
 - 3.1.4 *Glass Block* 61

- 3.2 Structural Clay Tile 62**
 - 3.2.1 *Loadbearing Wall Tile* 64
 - 3.2.2 *Non-Loadbearing Tile* 64
 - 3.2.3 *Facing Tile* 66
 - 3.2.4 *Ceramic Glazed Facing Tile* 66
 - 3.2.5 *Screen Tile* 70

- 3.3 Terra Cotta 70**

3.4 Properties and Characteristics of Fired Clay Products 72

- 3.4.1 *Compressive Strength* 74
- 3.4.2 *Transverse Strength* 74
- 3.4.3 *Absorption* 75
- 3.4.4 *Durability* 76
- 3.4.5 *Expansion Coefficients* 76
- 3.4.6 *Fire and Thermal Resistance* 77
- 3.4.7 *Acoustical Characteristics* 77
- 3.4.8 *Colors and Textures* 77

3.5 Adobe Masonry 78

- 3.5.1 *Manufacturing Adobe* 78
- 3.5.2 *Physical Properties and Characteristics* 80
- 3.5.3 *Adobe Mortar* 81

4 CEMENTITIOUS MASONRY UNITS

83

4.1 Concrete Brick 83**4.2 Sand-Lime Brick 83****4.3 Cast Stone 85****4.4 Autoclaved Aerated Concrete Block 87****4.5 Concrete Block 87**

- 4.5.1 *Coring* 90
- 4.5.2 *Grading and Moisture Content* 90
- 4.5.3 *Sizes and Shapes* 90

4.6 Special Units 92

- 4.6.1 *Screen Block* 93
- 4.6.2 *Prefaced Units* 93
- 4.6.3 *Paving Units* 96
- 4.6.4 *Segmental Retaining Wall Units* 97

4.7 Properties and Characteristics 98

- 4.7.1 *Unit Strength* 98
- 4.7.2 *Absorption* 100
- 4.7.3 *Volume Changes* 102
- 4.7.4 *Fire, Sound, and Heat Resistance* 103
- 4.7.5 *Colors* 104

5 NATURAL STONE

105

5.1 Geological Characteristics 105**5.2 Properties 106****5.3 Production 108****5.4 Building Stone 112**

- 5.4.1 *Granite* 112
- 5.4.2 *Limestone* 114
- 5.4.3 *Marble* 116
- 5.4.4 *Slate* 117
- 5.4.5 *Sandstone* 118

5.5	Selecting Stone	118	
6	MORTAR AND GROUT		123
6.1	Mortar Properties	123	
6.1.1	Workability	123	
6.1.2	Water Retention and Flow	125	
6.1.3	Bond Strength	127	
6.1.4	Compressive Strength	129	
6.1.5	Extensibility and Volume Change	130	
6.1.6	Durability	130	
6.1.7	Efflorescence and Calcium Carbonate Stains	131	
6.2	Mortar Classification	131	
6.2.1	Clay Mortars	132	
6.2.2	Lime-Sand Mortars	132	
6.2.3	Portland Cement-Lime Mortars	132	
6.2.4	Masonry Cement Mortars	133	
6.2.5	"Mortar Cement" Mortars	135	
6.2.6	The Portland-Lime Mortar versus Masonry Cement Mortar Controversy	136	
6.3	Mortar Types	137	
6.3.1	Type M Mortar	137	
6.3.2	Type S Mortar	138	
6.3.3	Type N Mortar	138	
6.3.4	Type O Mortar	138	
6.3.5	Type K Mortar	138	
6.3.6	Choosing the Right Mortar Type	138	
6.3.7	Proportion versus Property Method of Specifying Mortar	140	
6.4	Specialty Mortars	142	
6.4.1	Refractory Mortars	143	
6.4.2	Chemical-Resistant Mortars	143	
6.5	Grout	143	
7	MASONRY ACCESSORIES		147
7.1	Metals and Corrosion	147	
7.2	Horizontal Joint Reinforcement	152	
7.3	Connectors	156	
7.3.1	Ties	156	
7.3.2	Anchors	159	
7.3.3	Fasteners	164	
7.4	Movement Joint Fillers	166	
7.5	Bar Positioners	166	
7.6	Flashing Materials	167	
7.7	Weep Hole Accessories	170	
7.8	Drainage Accessories	173	

PART 3 BUILDING SYSTEMS AND APPLICATIONS

8 WALL TYPES AND PROPERTIES	177
8.1 Single-Wythe Walls	179
8.2 Multi-Wythe Walls	179
8.3 Veneer Walls	184
8.4 Fire Resistance Characteristics	186
8.4.1 Fire Tests	187
8.4.2 Fire Resistance Ratings	191
8.4.3 UL Ratings	196
8.4.4 Steel Fireproofing	196
8.4.5 Compartmentation	197
8.4.6 Fire Insurance Rates	199
8.5 Thermal Properties	199
8.5.1 Thermal Inertia	206
8.5.2 The M Factor	210
8.6 Added Insulation	211
8.6.1 Granular Fills	213
8.6.2 Rigid Board Insulation and Insulation Inserts	214
8.6.3 Vapor Retarders and Air Barriers	217
8.6.4 Insulation Location	217
8.7 Energy Conservation	218
8.7.1 Shading Devices	219
8.7.2 Direct-Gain Solar Heating	220
8.7.3 Thermal Storage Walls	221
8.7.4 Vented Thermal Storage Walls	222
8.7.5 Hybrid Systems	223
8.8 Acoustical Properties	224
8.8.1 Sound Ratings	225
8.8.2 Sound Absorption	226
8.8.3 Sound Transmission	227
8.8.4 STC Ratings	228
8.9 Movement Characteristics	232
9 MOVEMENT AND MOISTURE CONTROL	235
9.1 Movement Characteristics	235
9.1.1 Temperature Movement	236
9.1.2 Moisture Movement	237
9.1.3 Elastic Deformation	239
9.1.4 Plastic Flow	240
9.1.5 Effects of Differential Movement	240

9.2	Flexible Anchorage	242	
9.3	Movement Joints	246	
9.3.1	Joint Design	247	
9.3.2	Joint Locations	251	
9.3.3	Accommodating Movement Joints in Design	254	
9.4	Moisture Protection	259	
9.4.1	Prevent Moisture Accumulation	263	
9.4.2	Limit Moisture Penetration	271	
9.4.3	Material Selection	278	
9.4.4	Waterproofing and Dampproofing	282	
9.4.5	Condensation and Vapor Retarders	283	
9.4.6	Calculating Condensation	284	
9.4.7	Coatings	286	
10	MASONRY WALLS AND VENEERS		291
10.1	Interior Partitions	292	
10.2	Screen Walls and Fences	294	
10.3	Glass Block Panels	309	
10.4	Single-Wythe Walls	312	
10.4.1	Empirical Design	313	
10.4.2	Analytical Design	316	
10.4.3	Water Penetration Resistance	317	
10.5	Multi-Wythe Walls	322	
10.5.1	Composite Walls	323	
10.5.2	Cavity Walls	324	
10.6	Masonry Veneer	326	
10.6.1	Adhered Veneer	326	
10.6.2	Anchored Veneer	328	
10.6.3	Brick and CMU Veneer	331	
10.6.4	Stone Veneer	339	
10.7	Parapets	341	
10.8	Shelf Angles	348	
11	LINTELS AND ARCHES		359
11.1	Lintels	359	
11.1.1	Load Determination	359	
11.1.2	Steel Lintels	363	
11.1.3	Concrete and Concrete Masonry Lintels	364	
11.1.4	Reinforced Brick Lintels	367	
11.1.5	Prefabrication	368	

11.2 Arches	368
11.2.1 Minor Arch Design	370
11.2.2 Graphic Analysis	371
11.2.3 Rotation	373
11.2.4 Sliding	373
11.2.5 Crushing	373
11.2.6 Thrust Resistance	375
11.2.7 Major Arch Design	376
12 STRUCTURAL MASONRY	379
12.1 Masonry Structural Systems	379
12.1.1 Axial Load Distribution	379
12.1.2 Lateral Load Distribution	381
12.1.3 Diaphragms	383
12.1.4 Masonry Shear Walls	383
12.1.5 Beams and Girders	389
12.1.6 Connections	391
12.1.7 Foundations	392
12.1.8 Reinforced and Unreinforced Masonry	393
12.1.9 Empirical and Analytical Design	395
12.1.10 Code Requirements	399
12.2 Empirical Design	399
12.2.1 Allowable Compressive Stresses	400
12.2.2 Lateral Support Requirements	400
12.2.3 Wall Thickness	400
12.2.4 Bonding	401
12.2.5 Corbeling	405
12.3 Analytical Design	405
12.3.1 Masonry Compressive Strength	411
12.3.2 Differential Movement	412
12.3.3 Unreinforced Masonry	413
12.3.4 Reinforced Masonry	413
12.3.5 Wind and Seismic Loads	414
13 FOUNDATION AND RETAINING WALLS	419
13.1 General Considerations	419
13.1.1 Soil Bearing Pressures	419
13.1.2 Lateral Earth Pressure	419
13.1.3 Frost Depth	421
13.1.4 Surcharge	421
13.1.5 Overturning and Sliding	421
13.1.6 Expansion and Control Joints	421
13.1.7 Materials	421
13.2 Foundation Walls	421
13.2.1 Design and Construction	424
13.2.2 Unreinforced Walls	427

13.2.3	<i>Reinforced Walls</i>	427
13.2.4	<i>Footings</i>	427
13.2.5	<i>Drainage and Waterproofing</i>	428
13.3	Retaining Walls	429
13.3.1	<i>Traditional Retaining Wall Types</i>	429
13.3.2	<i>Cantilever Walls</i>	431
13.3.3	<i>Footings</i>	432
13.3.4	<i>Drainage and Waterproofing</i>	432
13.3.5	<i>Segmental Retaining Walls</i>	435
14	MASONRY PAVING AND FIREPLACES	445
14.1	Masonry Paving	445
14.1.1	<i>Outdoor Paving</i>	446
14.1.2	<i>Bases</i>	446
14.1.3	<i>Setting Beds</i>	449
14.1.4	<i>Paving Joints</i>	449
14.1.5	<i>Membrane Materials</i>	452
14.1.6	<i>Masonry Units</i>	452
14.1.7	<i>Paving Patterns</i>	454
14.1.8	<i>Brick Steps</i>	454
14.2	Fireplaces	454
 PART 4 CONSTRUCTION PRACTICE		
15	INSTALLATION AND WORKMANSHIP	467
15.1	Moisture Resistance	467
15.2	Preparation of Materials	468
15.2.1	<i>Material Storage and Protection</i>	468
15.2.2	<i>Mortar and Grout</i>	468
15.2.3	<i>Masonry Units</i>	472
15.2.4	<i>Accessories</i>	473
15.2.5	<i>Layout and Coursing</i>	474
15.3	Installation	479
15.3.1	<i>Mortar and Unit Placement</i>	479
15.3.2	<i>Flashing and Weep Holes</i>	490
15.3.3	<i>Control and Expansion Joints</i>	493
15.3.4	<i>Accessories and Reinforcement</i>	496
15.3.5	<i>Grouting</i>	498
15.3.6	<i>Protections</i>	507
15.4	Prefabricated Masonry	513
15.5	Construction Tolerances	513
15.5.1	<i>Masonry Size Tolerances</i>	516
15.5.2	<i>Mortar Joints</i>	517

15.5.3	<i>Sealant Joints</i>	517
15.5.4	<i>Connections</i>	518
15.5.5	<i>Grout and Reinforcement</i>	520
15.6	Cold Weather Construction	521
15.7	Hot Weather Construction	523
15.8	Moist Curing	524
16	MASONRY CLEANING AND RESTORATION	527
16.1	Construction Cleaning	527
16.1.1	<i>Protections</i>	527
16.1.2	<i>Cleaning Methods</i>	528
16.1.3	<i>Cleaning Fresh Mortar Smears</i>	529
16.2	Efflorescence and Stains on Unit Masonry	530
16.2.1	<i>Efflorescence and Calcium Carbonate Stains</i>	530
16.2.2	<i>Vanadium and Manganese Stains</i>	534
16.2.3	<i>Stains From External Sources</i>	535
16.3	Cleaning Stone Masonry	536
16.4	Cleaning Historic Masonry	536
16.4.1	<i>Testing</i>	537
16.4.2	<i>Cleaning Methods</i>	538
16.4.3	<i>Precautions</i>	539
16.5	Repair and Repointing	540
16.5.1	<i>Repairs</i>	540
16.5.2	<i>Joint Preparation</i>	540
16.5.3	<i>Mortar</i>	541
16.5.4	<i>Pointing</i>	543
16.6	Color Matching Brick	543
17	QUALITY ASSURANCE AND QUALITY CONTROL	547
17.1	Standard of Quality	548
17.2	Quality Assurance Program	548
17.2.1	<i>Quality Assurance Requirements in Building Codes</i>	548
17.2.2	<i>Quality Assurance Requirements in the General Conditions</i>	549
17.2.3	<i>Quality Assurance Requirements in the Specifications</i>	549
17.3	Quality Control Procedures	551
17.3.1	<i>Quality Control Requirements in the General Conditions</i>	551
17.3.2	<i>Quality Control Requirements in the Specifications</i>	552
17.4	Field Observation and Inspection	553

17.5 Industry Standards for Masonry 554

- 17.5.1 Standards for Clay Masonry Units 554*
- 17.5.2 Standards for Concrete Masonry Units 557*
- 17.5.3 Standards for Masonry Mortar and Grout 558*
- 17.5.4 Standards for Masonry Accessories 559*
- 17.5.5 Standards for Laboratory and Field Testing 560*

17.6 Masonry Submittals 561

- 17.6.1 Specifying Submittals 561*
- 17.6.2 Submittal Procedures 563*
- 17.6.3 Shop Drawings 563*
- 17.6.4 Product Data 564*
- 17.6.5 Samples 564*
- 17.6.6 Quality Assurance / Quality Control Submittals 564*
- 17.6.7 Closeout Submittals 565*

17.7 Sample Panels and Mock-Ups 566

- 17.7.1 Sample Panel 566*
- 17.7.2 Mock-Up 566*
- 17.7.3 Grout Demonstration Panel 568*

18 SPECIFICATIONS AND FIELD OBSERVATION

569

18.1 Economic Considerations 569

- 18.1.1 Factors Affecting Cost 569*
- 18.1.2 Value Engineering 571*

18.2 Specification Guidelines 572

- 18.2.1 Mortar and Grout 572*
- 18.2.2 Masonry Accessories 573*
- 18.2.3 Masonry Units 573*
- 18.2.4 Construction 574*
- 18.2.5 Quality Control Tests 574*
- 18.2.6 Sample Panels and Mock-Ups 575*

18.3 Specifying with the MSJC Code 576

- 18.3.1 General 577*
- 18.3.2 Products 578*
- 18.3.3 Execution 578*

18.4 Field Observation and Inspection 579

- 18.4.1 Materials 580*
- 18.4.2 Construction 580*
- 18.4.3 Workmanship 581*
- 18.4.4 Protection and Cleaning 582*
- 18.4.5 Moisture Drainage 582*

APPENDIX A GLOSSARY

585

APPENDIX B ASTM REFERENCE STANDARDS

621

BIBLIOGRAPHY 625

INDEX 633

This page intentionally left blank.

PREFACE TO FIFTH EDITION

One of the primary changes to this edition is the introduction of the *International Building Code* and its requirements for masonry in lieu of the Uniform, Standard, and National codes. The Masonry Standards Joint Committee (MSJC) Building Code and Specification (ACI 530/ASCE 5/TMS 402) is still the primary code reference and, in fact, it is the primary reference for the new IBC as well. The 2000 edition of the IBC was based on the 1999 MSJC Code and the 2003 IBC is based on the 2002 MSJC Code. Code requirements have been expanded to include veneers, glass unit masonry, and prestressed masonry.

I have also added dozens of new details and photographs to help illustrate the recommendations made in the text. As always, the subject of moisture penetration resistance has been expanded, with new details for window flashing, parapet intersections, drainage accessories, and other items of recurring interest. A discussion of the basic principles of water penetration resistance has also been added to help shed light on the options available to architects and contractors today.

CHRISTINE BEALL, NCARB, CCS
Austin, Texas

This page intentionally left blank.

PREFACE TO FOURTH EDITION

This edition has been updated to reflect revisions in the 1994 edition of the *Uniform Building Code* and the 1995 edition of the Masonry Standards Joint Committee (MSJC) *Building Code Requirements for Masonry Structures* (ACI 530/ASCE 5/TMS 402) and *Specifications for Masonry Structures* (ACI 530.1/ASCE 6/TMS 602). The text has also been revised to include new ASTM standards and to change references to revised standards. The information on mortar selection has been expanded to better explain selection criteria and methods of specifying, and a new chapter has been added on quality assurance and quality control. The QA/QC chapter is intended to guide readers through the intricacies of specifying a quality assurance program for masonry, choosing the proper industry standards and ASTM quality control tests, and identifying appropriate levels of field observation or structural inspection. Information has also been added on new masonry products such as segmental retaining walls, EPDM and rubberized asphalt flashings, “mortar cement,” and seismic veneer anchors.

CHRISTINE BEALL, NCARB, CCS
Columbus, Texas

This page intentionally left blank.

PREFACE TO THIRD EDITION

There are several major changes in this edition. First of all, the text has been expanded significantly to cover new topics and discuss existing ones in greater detail. Along with this new text, many new drawings, tables and photographs have been added. New coverage includes discussion of the Masonry Standards Joint Committee, *Building Code Requirements for Masonry Structures* (ACI 530/ASCE 5/TMS 402) and its accompanying Specifications. Revisions have also been made to update code requirements for the 1991 *Uniform Building Code*, 1990 *National Building Code*, and 1991 *Standard Building Code*. Much of the detailed information that has been added first appeared in articles which I have written for the *Magazine of Masonry Construction*, *The Construction Specifier*, *Architecture*, and *Architectural Record*.

The text has also been reorganized to consolidate topics on structural design and to create separate chapters on Movement and Moisture Control, Paving and Fireplaces, and Cleaning and Restoration. This new arrangement should make information easier to find.

CHRISTINE BEALL, AIA
Austin, Texas

This page intentionally left blank.

PREFACE TO SECOND EDITION

This handbook addresses a broad range of aesthetic, technical, and environmental considerations. In addition to the engineering aspects of design, technical information on energy and sound control, maintenance, life-cycle costing, and workmanship is included. My goal has been to assemble and correlate existing industry information into a single, concise, and complete reference aimed at architects and other design professionals.

Two major sources of information have been publications of the Brick Institute of America and the National Concrete Association, especially the BIA "Technical Notes" series and the NCMA "TEK Bulletins." A bibliography of detailed sources is given at the back of this book as well as a list of national and regional masonry organizations through which design assistance can be obtained.

I would like to thank Excy Johnston, AIA, for preparing the sketches in Figs. 1-1 and 2-1; Gregg Borchelt, P.E., of the Masonry Institute of Houston/Galveston for his technical editing of Chapters 10, 11, and 12 and for the preparation of sample problems to accompany the text; Bernie Beall for typing the rough draft; and Kathy Cogburn for putting the text on computer disk.

Photographs and many technical illustrations, charts, graphs, and tables have been provided through the courtesy of the Brick Institute of America, the National Concrete Masonry Association, the American Concrete Institute, the Masonry Institute of America, and the Portland Cement Association.

CHRISTINE BEALL, AIA
Austin, Texas

This page intentionally left blank.

PART **1**

INTRODUCTION

This page intentionally left blank.

1

HISTORY AND DEVELOPMENT OF MASONRY TECHNOLOGY

The unwritten record of history is preserved in buildings—in temples, fortresses, sanctuaries, and cities constructed of brick and stone. Early efforts to build permanent shelter were limited to the materials at hand. The trees of a primeval forest, the clay and mud of a river valley, the rocks, caves, and cliffs of a mountain range afforded only primitive opportunity for protection, security, and defense and few examples survive. But the stone and brick of skeletal architectural remains date as far back as the temples of Ur built in 3000 B.C., the early walls of Jericho of 8000 B.C., and the vaulted tombs at Mycenae of the fourteenth century B.C. It was the permanence and durability of the masonry which safeguarded this prehistoric record of achievements, and preserved through centuries of war and natural disaster the traces of human development from cave dweller to city builder. Indeed, the history of civilization is the history of its architecture, and the history of architecture is the history of masonry.

1.1 DEVELOPMENT Stone is the oldest, most abundant, and perhaps the most important *raw building material* of prehistoric and civilized peoples. Stone formed their defense in walls, towers, and embattlements. They lived in buildings of stone, worshiped in stone temples, and built roads and bridges of stone. Builders began to form and shape stone when tools had been invented that were hard enough to trim and smooth the irregular lumps and broken surfaces. Stone building was then freed from the limitations of monolithic slab structures like those at Stonehenge and progressed through the shaped and fitted blocks of the Egyptians to the intricately carved columns and entablatures of the Greeks and Romans.

Brick is the oldest *manufactured* building material, invented almost 10,000 years ago. Its simplicity, strength, and durability led to extensive use, and gave it a dominant place in history alongside stone.

Rubble stone and mud bricks, as small, easily handled materials, could be stacked and shaped to form enclosures of simple or complex design. Hand-shaped, sun-dried bricks, reinforced with such diverse materials as straw and dung, were so effective that kiln-fired bricks did not appear until the third millennium B.C., long after the art of pottery had demonstrated the effects of high temperatures on clay. Some of the oldest bricks in the world, taken from archaeological digs at the site of ancient Jericho, resemble long loaves of bread with a bold pattern of Neolithic thumbprint impressions on their rounded tops (see Fig. 1-1). The use of wooden molds did not replace such hand-forming techniques until the early Bronze Age, around 3000 B.C.

Perhaps the most important innovations in the evolution of architecture were the development of masonry arches and domes. Throughout history, the arch was the primary means of overcoming the span limitations of single blocks of stone or lengths of timber, making it possible to bridge spaces once thought too great. Early forms only approximated true “arching” action and were generally false, corbeled arches. True arches carry their loads in simple compression to each abutment, and as long as the joints are roughly aligned at right angles to the compressive stress, the precise curve of the arch is not critical.

The excavation of ruins in Babylonia exposed a masonry arch believed to have been built around 1400 B.C. Arch construction reached a high level of refinement under the Romans, and later developments were limited primarily to the adaptation of different shapes. Islamic and Gothic arches led to the design of groined vaults, and eventually to the high point of cathedral architecture and masonry construction in the thirteenth century.

Simple dome forms may actually have preceded the true arch because, like the corbeled arch, they could be built with successive horizontal rings of masonry, and required no centering. These domes were seen as circular walls gradually closing in on themselves rather than as rings of vertical arches. Barrel vaults were built as early as the thirteenth century B.C., and could also be constructed without centering if one end of the vault was closed off.

Initial exploitation of the true dome form took place from the mid-first century A.D. to the early second century, under the reigns of Nero and Hadrian. The brick dome of the Pantheon in Rome exerts tremendous outward thrusts counteracted only by the massive brick walls encircling its perimeter. Later refinements included the masonry squinch and pendentive, which were instrumental in the construction of the dome of the Florence Cathedral, and buttressing by means of half domes at the sides, as in the Church of Hagia Sophia in Constantinople.

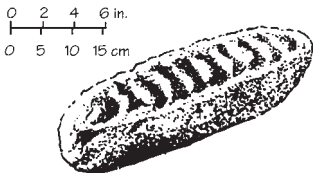


Figure 1-1 Sun-dried brick, circa 8000 B.C.

1.2 DECLINE Renaissance architecture produced few significant innovations in structural building practices, since designs were based primarily on the classical forms of earlier eras. The forward thrust of structural achievements in masonry essentially died during this period of “enlightenment,” and masonry structures remained at an arrested level of development.

With the onslaught of the Industrial Revolution, emphasis shifted to iron, steel, and concrete construction. The invention of portland cement in 1824, refinements in iron production in the early nineteenth century, and the development of the Bessemer furnace in 1854 turned the creative focus of architecture away from masonry.

By the early twentieth century, the demand was for high-rise construction, and the technology of stone and masonry building had not kept pace with the developments of other structural systems. The Chicago School had pioneered the use of iron and steel skeleton frames, and masonry was relegated to secondary usage as facings, in-fill, and fireproofing. The Monadnock Building in Chicago (1891) is generally cited as the last great building in the “ancient tradition” of masonry architecture (see Fig. 1-2). Its 16-story *unreinforced* loadbearing walls were required by code to be several feet thick at the base, making it seem unsuited to the demands of a modern industrialized society. Except for the revivalist periods following the 1893 World’s Columbian Exposition and the “mercantile classicism” which prevailed for some time, a general shift in technological innovation took place, and skeleton frame construction began to replace loadbearing masonry.

During this period, only Antonio Gaudi’s unique Spanish architecture showed innovation in masonry structural design (see Fig. 1-3). His “structural rationalism” was based on economy and efficiency of form, using ancient Catalan vaulting techniques, parabolic arches, and inclined piers to bring the supporting masonry under compression. His work also included vaulting with hyperbolic paraboloids and warped “helicoidal” surfaces for greater structural strength. Gaudi, however, was the exception in a world bent on developing lightweight, high-rise building techniques for the twentieth century.

At the time, most considered both concrete and masonry construction to be unsophisticated systems with no tensile strength. Very soon, however, the introduction of iron and steel reinforcement brought concrete a step forward. While concrete technology developed rapidly into complex steel-reinforced systems, masonry research was virtually non-existent, and the widespread application of this new reinforcing technique to masonry never occurred.

The first reinforced concrete building, the Eddystone Lighthouse (1774), was actually constructed of both concrete *and* stone, but the use of iron or steel as reinforcing was soon limited almost entirely to concrete. A few reinforced brick masonry structures were built in the early to mid-nineteenth century, but these experiments had been abandoned by about 1880. Reinforced masonry design was at that time intuitive or empirical rather than rationally determined, and rapid advances in concrete engineering quickly outpaced what was seen as an outmoded, inefficient, and uneconomical system. Even by the time the Monadnock Building was constructed, building codes still recognized lateral resistance of masonry walls only in terms of mass, and this did indeed make the system expensive and uneconomical.

1.3 REVIVAL In the early 1920s, economic difficulties in India convinced officials that alternatives to concrete and steel structural systems had to be found. Extensive research began into the structural performance of reinforced



Figure 1-2 The Monadnock Building in Chicago (1891, Burnham and Root architects) was the last unreinforced high-rise masonry building. (Photo courtesy of the School of Architecture Slide Library, the University of Texas at Austin.)

masonry, which led not only to new systems of low-cost construction, but also to the first basic understanding of the structural behavior of masonry. It was not until the late 1940s, however, that European engineers and architects began serious studies of masonry bearing wall designs—almost 100 years after the same research had begun on concrete bearing walls.



(A)



(C)



(B)

Figure 1-3 Gaudi's innovative masonry structures: (A) warped masonry roof, Schools of the Sagrada Família Church; (B) thin masonry arch ribs, Casa Mila; and (C) inclined brick column, Colonia Guell Chapel. (Photos courtesy of the School of Architecture Slide Library, the University of Texas at Austin.)

By that time, manufacturers were producing brick with compressive strengths in excess of 8000 psi, and portland cement mortars had strengths as high as 2500 psi. Extensive testing of some 1500 wall sections generated the laboratory data needed to develop a rational design method for masonry. These studies produced the first reliable, mathematical analysis of a very old material, freed engineers for the first time from the constraints of empirical design, and allowed formulation of rational structural theories. It was found that no new techniques of analysis were required, but merely the application of accepted engineering principles already being used on other systems.

The development of recommended practices in masonry design and construction in the United States took place during the decade of the 1950s, and resulted in publication of the first "engineered masonry" building code in 1966. Continued research throughout the following two decades brought about refinements in testing methods and design procedures, and led to the adoption of engineered masonry structural systems by all of the major building

codes in the United States. Laboratory and field tests have also identified and defined the physical properties of masonry and verified its excellent performance in fire control, sound attenuation, and thermal resistance.

Masonry construction today includes not only quarried stone and clay brick, but a host of other manufactured products as well. Concrete block, cast stone, structural clay tile, terra cotta, glass block, mortar, grout, and metal accessories are all a part of the mason's trade. In various definitions of masonry, this group of materials is often expanded to include concrete, stucco, or precast concrete. However, the most conventional application of the term "masonry" is limited to relatively small building units of natural or manufactured stone, clay, concrete, or glass that are assembled by hand, using mortar, dry-stacking, or mechanical connectors.

1.4 CONTEMPORARY MASONRY

Contemporary masonry may take one of several forms. Structurally, it may be divided into loadbearing and non-loadbearing construction. Walls may be of single- or multi-wythe design. They may also be solid masonry, solid walls of hollow units, or cavity walls. Finally, masonry may be reinforced or unreinforced, and either empirically or analytically designed. Loadbearing masonry supports its own weight as well as the dead and live loads of the structure, and all lateral wind and seismic forces. Non-loadbearing masonry also resists lateral loads, and veneers may support their own weight for the full height of the structure, or be wholly supported by the structure at each floor. Solid masonry is built of solid units or fully grouted hollow units in multiple wythes with the collar joint between wythes filled with mortar or grout. Solid walls of hollow units have open cores in the units, but grouted collar joints. Cavity walls have two or more wythes of solid or hollow units separated by an open collar joint or cavity at least 2 in. wide (see Fig. 1-4). Masonry veneers are applied over non-masonry backing walls.

Empirical designs are based on arbitrary limits of height and wall thickness. Engineered designs, however, are based on rational analysis of the loads and the strength of the materials used in the structure. Standard calculations are used to determine the actual compressive, tensile, and shear stresses, and the masonry designed to resist these forces. Unreinforced masonry is still sometimes designed by empirical methods, but is applicable only to low-rise structures with modest loads. Unreinforced masonry is strong in compression, but weak in tension and flexure (see Fig. 1-5). Small lateral loads and overturning moments are resisted by the weight of the wall. Shear and flexural stresses are resisted only by the bond between mortar and units. Where lateral loads are higher, flexural strength can be increased by solidly grouting reinforcing steel into hollow unit cores or wall cavities wherever design analysis indicates that tensile stress is developed. The cured grout binds the masonry and the steel together to act as a single load-resisting element.

Contemporary masonry is very different from the traditional construction of earlier centuries. Its structural capabilities are still being explored as continuing research provides a better understanding of masonry structural behavior. Contemporary masonry buildings have thinner, lighter-weight, more efficient structural systems and veneers than in the past, and structures designed in compliance with current code requirements perform well, even in cases of significant seismic activity and extreme fire exposure.

1.5 COMMON CONCERNS

Although there is continuing structural research aimed at making masonry systems stronger, more efficient, and more economical, many of the concerns

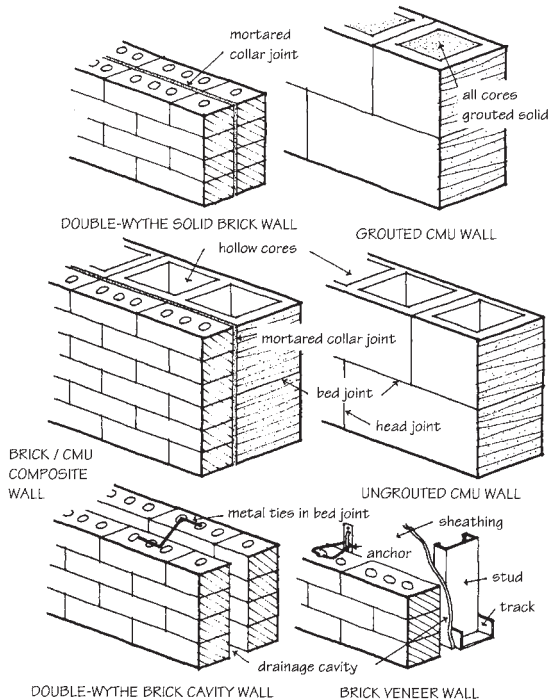
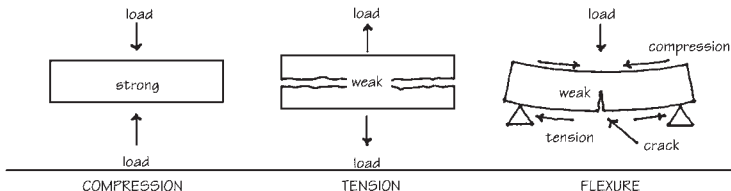


Figure 1-4 Examples of masonry wall types.

commonly expressed by both design professionals and contractors are related to weather resistance. Moisture penetration and durability, in fact, seem to be more significant day-to-day issues for most than structural performance. Building codes, which have traditionally provided minimum performance requirements only for structural and life safety issues, are now beginning to address water penetration, weather resistance, and durability issues for masonry as well as other building systems.

Contemporary masonry walls are more water permeable than traditional masonry walls because of their relative thinness, and more brittle because of the portland cement that is now used in masonry mortar. As is the case with any material or system used to form the building envelope, the movement of moisture into and through the envelope has a significant effect on the performance of masonry walls. Contemporary masonry systems are designed, not with the intent of providing a barrier to water penetration, but as drainage walls in which penetrated moisture is collected on flashing membranes and



Masonry is strong in compression and resists tensile and flexural stresses through the incorporation of reinforcing steel.

Figure 1-5 Compressive, tensile, and flexural strength of masonry.

expelled through a series of weep holes. Higher-performance wall systems for extreme weather exposures can be designed as pressure-equalized rain screens, but at a higher cost than drainage walls. Design, workmanship, and materials are all important to the performance of masonry drainage and rain screen walls:

- Mortar joints must be full
- Mortar must be compatible with and well bonded to the units
- Drainage cavity must be kept free of mortar droppings
- Appropriate flashing material must be selected for the expected service life of the building
- Flashing details must provide protection for all conditions
- Flashing must be properly installed
- Weep holes must be properly sized and spaced
- Weep holes must provide rapid drainage of penetrated moisture

With adequate provision for moisture drainage, masonry wall systems can provide long-term performance with little required maintenance. The chapters which follow discuss materials, design, and workmanship with an eye toward achieving durability and weather resistance as well as adequate structural performance in masonry systems.

2

RAW MATERIALS AND MANUFACTURING PROCESSES

The quality and characteristics of masonry products are directly and exclusively determined by the raw materials and methods of manufacture used in their production. A basic introduction to this aspect of masonry will aid in understanding the finished products and how they may best be used in specific design applications.

2.1 CLAY MASONRY

Clay, the raw material from which brick, structural clay tile, and terra cotta are made, is the most plentiful natural substance used in the production of any building product. Clay is the end product of the chemical alteration over long periods of time of the less stable minerals in rock. This chemical weathering produces minute particles that are two-dimensional or flake-shaped. The unique plastic characteristics of clay soils are a result of the enormous amount of surface area inherent in this particle size and shape. The natural affinity of clay soils and moisture results in cohesiveness and plasticity from the surface tension of very thin layers of water between each of these minute particles. It is this plasticity which facilitates the molding and shaping of moist clay into usable shapes.

For the architect, the importance of understanding clay characteristics and methods of manufacture is their relationship to finished appearance and physical properties. Color depends first on the composition of the raw material and the quantitative presence of metallic oxides. Second, it is an indication of the degree of burning to which the clay has been subjected. Lighter-colored units (called salmons) for a given clay are normally associated with under-burning. They may also be indicative of high porosity and absorption along with decreased strength, durability, and resistance to abrasion. On the other hand,

the very dark colored units (called clinkers) produced from the same clay result from over-burning. This indicates that the units have been pressed and burned to a very high compressive strength and abrasion resistance, with greatly reduced absorption and increased resistance to freezing and thawing.

Most of the brick used in building construction falls between the extremes of salmon and clinker brick. Since clay composition is the primary determinant of brick color, lightness or darkness cannot be used as an absolute indicator of physical properties for brick made from different raw materials. It can, however, assist generally in the evaluation and selection of brick to meet specific design or exposure requirements.

2.1.1 Clay Composition

Clays are basically compounds of silica and alumina with varying amounts of metallic oxides and other minor ingredients and impurities. Metallic oxides act as fluxes to promote fusion at lower temperatures, influence the range of temperatures in which the material vitrifies, and give burned clay the necessary strength for structural purposes. The varying amounts of iron, calcium, and magnesium oxides also influence the color of fired clay.

Clays may be classified as either calcareous or non-calcareous. While both are hydrous aluminum silicates, the calcareous clays contain around 15% calcium carbonate, which produces a yellowish color when fired. The non-calcareous clays are influenced by feldspar and iron oxide. The oxide may range from 2 to 25% of the composition, causing the clay to burn from a buff to a pink or red color as the amount increases.

Any lime that is present in a clay must be finely crushed to eliminate large lumps. Lime becomes calcined in the burning process and later slakes or combines with water when exposed to the weather, so that any sizable fragments will expand and possibly chip or spall the brick.

2.1.2 Clay Types

There are three different types of clay which, although they are similar in chemical composition, have different physical characteristics. Surface clays, shales, and fire clays are common throughout the world, and result from slight variations in the weathering process.

Surface clay occurs quite close to the earth's surface, and has a high oxide content, ranging from 10 to 25%. Surface clays are the most accessible and easily mined, and therefore the least expensive.

Shale is a metamorphic form of clay hardened and layered under natural geologic conditions. It is very dense and harder to remove from the ground than other clays, and as a result, is more costly. Like surface clay, shale contains a relatively high percentage of oxide fluxes.

Fire clay is formed at greater depths than either surface clay or shale. It generally has fewer impurities, more uniform chemical and physical properties, and only 2 to 10% oxides. The lower percentage of oxide fluxes gives fire clay a much higher softening point than surface clay and shale, and the ability to withstand very high temperatures. This refractory quality makes fire clay best suited to producing brick and tile for furnaces, fireplaces, flue liners, ovens, and chimney stacks. The low oxide content also causes the clay to burn to a very light brown or light buff color, approaching white.

Clay is well suited to the manufacture of masonry products. It is plastic when mixed with water, and easily molded or formed into the desired shapes; it has sufficient tensile strength to maintain those shapes after the dies or molds are removed; and its particles are ceramically fused at high temperatures.

2.1.3 Material Preparation

Brick plants commonly mine from several clay pits at a time. Since the raw clay is not always uniform in quality and composition, two or more clays from different pits or from remote locations within the same pit are blended to minimize much of the natural variation in chemical composition and physical properties. Blending produces a higher degree of product uniformity, helps control the color of the units, and permits some latitude in providing raw material suitable for specific types of brick or special product requirements. The clay is first washed to remove stones, soil, or excessive sand, then crushed into smaller pieces, and finally ground to a powdered mix. Particle size is carefully controlled so that only the finer material is taken to storage bins or directly to the forming machine or pug mill for tempering and molding.

2.1.4 Manufacturing

After preparation of the raw clay, the manufacture of fired brick is completed in four additional stages: *forming, drying, burning, and drawing and storage* (see Fig. 2-1). The basic process is always the same, and differences occur only in the molding techniques. In ancient as well as more recent history, brick was exclusively hand-made. Since brick-making machines were invented in the late nineteenth century, however, most of the structural clay products manufactured in the United States are machine-made by one of three forming methods: *stiff-mud, soft-mud, or dry-press*.

2.1.5 Forming

The first step in each forming method is tempering, where the clay is thoroughly mixed with a measured amount of water. The amount of water and the desired plasticity vary according to the forming method to be used.

The *stiff-mud extrusion method* is used for more than 80% of the brick manufactured in the United States. A minimum amount of water, generally 12 to 15% moisture by weight, is mixed with the dry clay to make it plastic. After thorough mixing in a pug mill, the tempered clay goes through a de-airing process which increases the workability and plasticity of the clay and produces units with greater strength. The clay is then forced through a steel die in a continuous extrusion of the desired size and shape, and at the same time, is cored to reduce weight and to facilitate drying and burning. Automatic cutting machines using thin wires attached to a circular steel frame cut the extruded clay into pieces (see Fig. 2-2). Since the clay will shrink as it is dried and burned, die sizes and cutter wire spacing must be carefully calculated to compensate. Texturing attachments may be affixed to roughen, score, scratch, or otherwise alter the smooth skin of the brick column as it emerges from the die (see Fig. 2-3). After cutting, a clay slurry of contrasting color or texture may also be applied to the brick surface to produce different aesthetic effects.

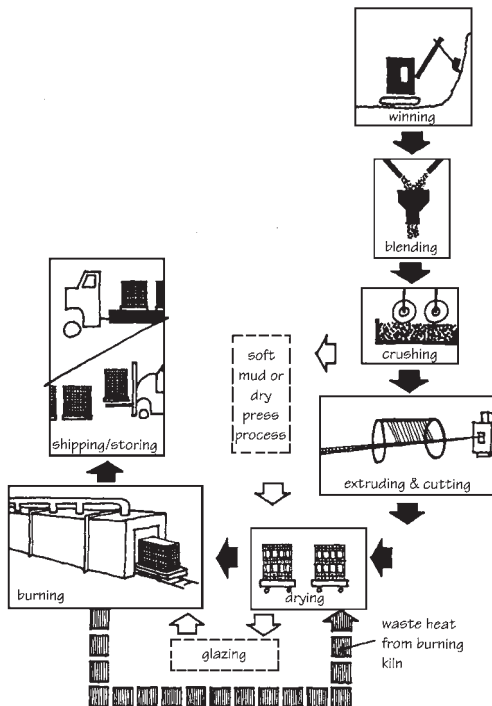


Figure 2-1 Brick manufacturing process.

A conveyor belt moves the “green” or wet brick past inspectors, who remove imperfect units and return them to the pug mill. Satisfactory units are moved from the conveyor to dryer cars and stacked in a prescribed pattern to allow free flow of air and kiln gases for burning. The stiff-mud process produces the hardest and most dense of the machine-made bricks, and also delivers the highest volume of production.

The *soft-mud method* of production is the oldest, and was used exclusively up until the nineteenth century (see Fig. 2-4). All hand-made brick is formed by this process even today. Only a few manufacturers still produce genuine hand-made brick, but demand is increasing as more historic restoration projects are undertaken.

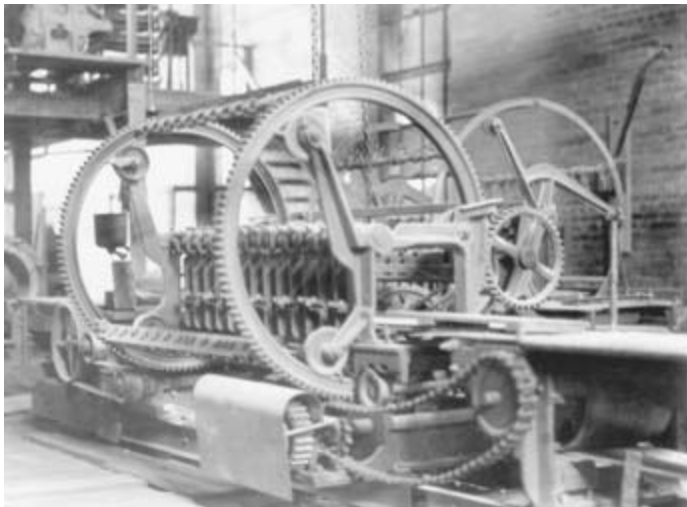


Figure 2-2 Wire-cutting extruded, stiff-mud brick. (Photo courtesy BIA.)

Automated machinery can accomplish soft-mud molding more uniformly and efficiently than hand work, and is now widely used. The soft-mud process is particularly suitable for clays which contain too much natural water for the extrusion method. The clay is tempered to a 20 to 30% moisture content (about twice that of the stiff-mud clays) and then pressed into wooden molds by hand or machine to form standard or special shapes. To prevent the clay from sticking, the molds are lubricated with sand or water. The resulting “sand-struck” or “water-struck” brick has a unique appearance characterized by either a rough, sandy surface or a relatively smooth surface with only slight texture variations from the individual molds (see Fig. 2-3). In addition to having an attractive rustic appearance, soft-mud units are more economical to install because less precision is required, and bricklayers can usually achieve a higher daily production. Manufacturers often simulate the look of hand-made brick by tumbling and roughening extruded brick.

The mortar bedding surfaces of sand-struck or sand-molded brick must be brushed clean of loose sand particles so that mortar bond is not adversely affected. Even if sand is not actually applied to the bed surfaces in the manufacturing process, stray particles along the edge of a unit can inhibit the critical mortar-to-unit bond at the weathering face of a wall, creating an unwanted increase in moisture penetration.

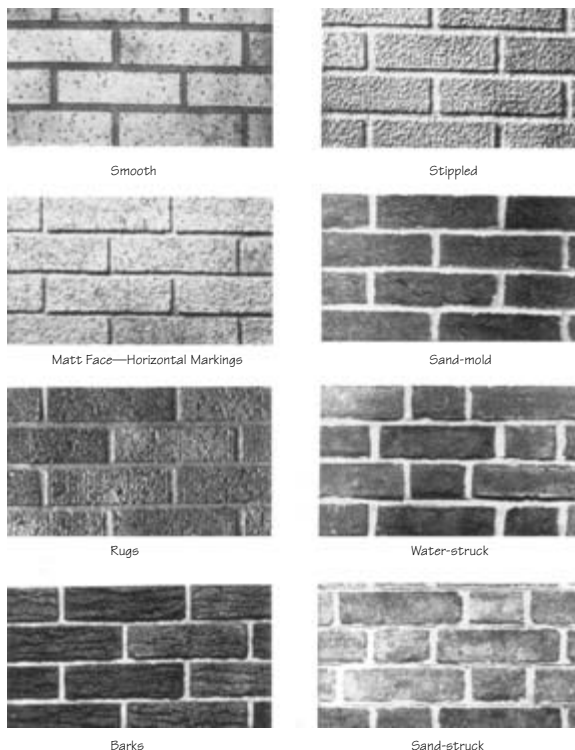


Figure 2-3 Typical clay brick textures. (Photo courtesy BIA.)

The *dry-press method*, although it produces the most accurately formed units, is used for less than 0.5% of U.S.-made brick. Clays of very low natural plasticity are required, usually with moisture contents of 10% or less. The relatively dry mix is pressed into steel molds by hydraulic plungers exerting a force of 500 to 1500 psi to form the unit.

2.1.6 Drying

Green clay units coming from the molding or cutting machines may contain 10 to 30% free moisture, depending on the forming process used. Before

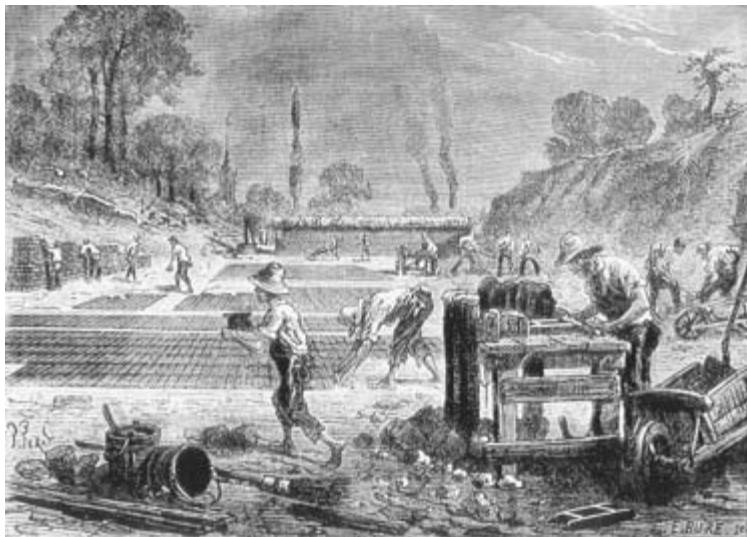


Figure 2-4 Artist's engraving of a colonial brick-making operation. (Courtesy BIA.)

burning can begin, most of this excess must be evaporated. The open sheds once used for natural air drying were affected by weather conditions, and the evaporation process took anywhere from 7 days to 6 weeks. Today, brick plants use separate dryer kilns or chambers supplied with waste heat from the exhaust of the firing kilns. Drying time takes only 24 to 48 hours, depending on the original moisture content. Drying temperatures range from 100 to 400°F, but must be carefully regulated, along with humidity, to prevent sudden changes which could crack or warp the units.

2.1.7 Glazing

Glazing is a highly specialized, carefully controlled procedure used in the production of decorative brick. *High-fired ceramic glazes* are the most widely used. The glaze is a blend of clays, ceramic frit, fluxes, and base metals sprayed on the units before burning, and then subjected to normal firing temperatures to fuse it to the clay body. Glazes with a higher flux content will burn to a glossy finish, while more refractory mixes produce a matte glaze. After the basic glass material is prepared, ceramic pigments are used to stain it to the desired color. Cobalt, vanadium, chrome, tin, nickel, alumina, and other metals are used singly or in combinations to produce standard,

custom, or color-matched blues, greens, ochers, pinks, lavenders, buffs, grays, and blacks. Color consistency is easier to maintain with high-gloss glazes, both within batches and between kiln runs.

Low-fired glazes are for colors which cannot be produced at high firing temperatures such as bright red, bright yellow, burgundy, and orange. If fired too hot, bright red, for instance, will craze or burn transparent because the cadmium and lead in the glaze are unstable at high temperatures. The glaze is applied after the brick has been burned to maturity, and then requires a second firing at lower temperatures of 1300 to 1800°F. Low-fired glazes are much more expensive because of the two-step process.

Clay coat glazes (sometimes called slip glazes) produce a dull, nonreflective, vitreously applied surface in softer tones than ceramic glazes. *Salt glazes* are produced by applying a vapor of sodium-iron silicate to the brick while it is at maximum firing temperature. The transparent finish shows the natural color of the fired brick under a lustrous gloss.

Producing some ceramic glazes leaves contaminants in the kiln which can affect the next batch of brick. The residue from ceramic glazes is also classified by the Environmental Protection Agency as hazardous waste which must be recovered for reuse or disposal.

2.1.8 Burning

After excess moisture has been evaporated from the clay units and desired glazes, if any, have been applied, the bricks are ready for burning. This is one of the most specialized and critical steps in the manufacture of clay products. Burning is accomplished by controlled firing in a kiln to achieve ceramic fusion of the clay particles and hardening of the brick. Since so many of the properties of brick and clay tile depend on the method and control of firing, the development over the years of more sophisticated kilns has been instrumental in improving the quality and durability of clay masonry.

Originally, bricks were cured by sun drying. This permitted hardening by evaporation, but did not achieve the chemical fusion necessary for high strength. High-temperature kiln firing of clay brick was done as early as 3500 B.C. Early scove kilns heated by wood fires were eventually replaced by beehive kilns. The heat source was originally at the bottom of the kiln, and could not be controlled effectively, so uneven firing resulted in hard-burned “clinker” brick nearest the fire and soft, under-burned “salmon” brick at the top of the kiln. Salmon bricks were sometimes used in unexposed locations such as filler courses in multi-wythe walls, but clinker bricks were usually discarded. Builders in colonial Williamsburg, Virginia, however, were fond of clinker brick and often used shiny, black, overburned units as headers to create checkerboard patterns with ordinary red brick. Tudor style homes of the early 1900s also used clinker brick in the same way. Some manufacturers still produce and sell clinkers for use, not only in restoring or renovating old buildings which used clinkers originally, but in new construction as well. The dark-colored, warped, or twisted shapes provide textures which are unusual in brick walls.

Beehive kilns were later heated by more precisely controlled gas and oil fires in separate fireboxes. Heat was circulated by a system of ducts from both the bottom and the top of the kiln, which resulted in more uniform firing of the brick. However, the excessive time required for burning in a “periodic” kiln of this nature yields only a limited quantity of bricks.

Most plants now use continuous straight-line tunnel kilns, with sophisticated computer equipment for precisely controlled firing temperatures (see Fig. 2-5). The clayware, which is stacked on flat rail cars for drying, is moved

into the first stage of the tunnel kiln, where it travels through various temperature zones. A European manufacturer has recently patented a “rotary circular kiln” that can reportedly save up to 30% on fuel consumption. Bricks move through the kiln on a hydraulically controlled turntable. The system can capture and reuse 70 to 75% of the waste heat compared to only about 45% for tunnel kilns.

Burning consists essentially of subjecting brick units to gradually increasing temperatures until fusion chemically alters the structure of the clay. The burning process consists of six phases which are accomplished in the dryer kiln and in the preheating, firing, and cooling chambers of the burning kiln. The drying and evaporating of excess moisture are often called the water-smoking stage. This initial preheat may be done in separate dryers or, if high-fired glazes will not be added, in the forward section of the burning kiln. This exposure to relatively low temperatures of up to 400°F begins the gradual, controlled heating process. Dehydration, or removal of the remaining trapped moisture, requires anywhere from 300 to 1800°F, oxidation from 1000 to 1800°F, and vitrification from 1600 to 2400°F. It is only within this final temperature range that the silicates in the clay melt and fill the voids between the more refractory materials binding and cementing them together to form a strong, dense, hard-burned brick. The actual time and exact temperatures required throughout these phases vary according to the fusing characteristics and moisture content of the particular clay. Near the end of the vitrification phase, a reducing atmosphere may be created in which there is insufficient oxygen for complete combustion. This variation in the process is called flashing, and is intended to produce different hues and shadings from the natural clay colors. For example, if the clay has a high iron oxide content, an oxygen-rich fire will produce a red brick. If the same clay is fired in a reducing atmosphere with low oxygen, the brick will be more purple.



Figure 2-5 Tunnel kilns provide even heat distribution.

The final step in the firing of brick masonry is the cooling process. In a tunnel kiln, this normally requires up to 48 hours, as the temperatures must be reduced carefully and gradually to avoid cracking and checking of the brick.

2.1.9 Drawing and Storage

Removing brick from the kiln is called drawing. The loaded flatcars leave the cooling chamber and are placed in a holding area until the bricks reach room temperature. They are then sorted as necessary for size, chippage, and warpage tolerances, bound into “cubes” equaling 500 standard-size bricks, and either moved to storage yards or loaded directly onto trucks or rail cars for shipment.

2.2 CONCRETE MASONRY

The development of modular concrete masonry was a logical outgrowth of the discovery of portland cement, and was in keeping with the manufacturing trends of the Industrial Revolution. Although the first rather unsuccessful attempts produced heavy, unwieldy, and poorly adaptable units, the molding of cementitious ingredients into large blocks promised a bright new industry. With the invention and patenting of various block-making machines, unit concrete masonry began to have a noticeable effect on building and construction techniques of the late nineteenth and early twentieth centuries. Concrete masonry today is made from a relatively dry mix of cementitious materials, aggregates, water, and occasionally special admixtures. The material is molded and cured under controlled conditions to produce a strong, finished block that is suitable for use as a structural building element. Both the raw materials and the method of manufacture influence strength, appearance, and other critical properties of the block and are important in understanding the diversity and wide-ranging uses of concrete masonry products.

2.2.1 Aggregates

The aggregates in concrete block and concrete brick account for as much as 90% of their composition. The characteristics of these aggregates therefore play an important role in determining the properties of the finished unit. Aggregates may be evaluated on the basis of (1) hardness, strength, and resistance to impact and abrasion; (2) durability against freeze-thaw action; (3) uniformity in gradation of particle size; and (4) absence of foreign particles or impurities. A consistent blend of fine and coarse particle sizes is necessary to produce a mixture that is easily workable and a finished surface that is dense and resistant to absorption.

There are two categories of aggregates used in the manufacture of concrete masonry: *lightweight aggregates* and *heavyweight aggregates* (also called normal-weight). Early concrete masonry units were, for the most part, made with the same heavyweight aggregates as those used today. Well-graded sand, gravel, crushed stone, and air-cooled slag are combined with other ingredients to produce a block that is heavy, strong, and fairly low in water absorption. Heavyweight aggregates for concrete masonry are covered in ASTM C33, *Standard Specification for Concrete Aggregates*.

Efforts to make handling easier and more efficient led to the introduction of lightweight aggregates. Pumice, cinders, expanded slag, and other natural or processed aggregates are often used, and the units are sometimes marketed under proprietary trade names. Testing and performance have proved that lightweight aggregates affect more than just weight, however. Thermal, sound,

and fire resistance are also influenced, as well as color and texture. Lightweight aggregates increase the thermal and fire resistance of concrete masonry, but sound transmission ratings generally are lower because of reduced density. Moisture absorption is also generally much higher with lightweight aggregates. Lightweight aggregates are covered by ASTM C331, *Standard Specification for Lightweight Concrete Aggregates for Masonry Units*.

In an effort to recycle materials, reduce landfill demand, and economize production, some block manufacturers are now using crushed block as a portion of the aggregate content in manufacturing new units. Broken units are crushed and blended with new aggregate to save money on raw materials and to give contractors an alternative means for disposing of construction site debris. Currently about 50 to 60% of the block produced at some manufacturing plants uses at least some recycled material, and companies are finding new ways to blend aggregates in order to use more recycled material. Some federal agencies are already requiring certain percentages of recycled-content materials in new construction projects.

Concrete masonry colors resulting from the mix of aggregate and cement may range from white, to buff or brownish tones, to dull grays. Special colors may be produced by the use of selected crushed stones or the addition of special pigments. Color variation in units is affected by several things. Aggregate gradation should be carefully controlled during manufacture, but shipping of raw materials, particularly by rail, can cause separation of fine surface material from coarse aggregate. The degree of separation and resultant dust content varies from one shipment to the next, causing a variation in the color of the block (particularly with split face units). As ambient temperatures rise during the day, moisture evaporates from the aggregate. If the moisture content is not accurately monitored, particularly in hot climates, the drier aggregate effectively changes the water-cement ratio of the mix within a single day's production. Higher water-cement ratios produce lighter-colored block. Temperature and moisture variations in the kiln affect unit color, and units loaded first may also experience a slightly longer hydration period. Units which are air-dried can be significantly affected by changes in ambient temperature and relative humidity.

Surface textures depend on the size and gradation of aggregates. Classification of surface effects is only loosely defined as "open" or "tight," with either fine, medium, or coarse texture. Although interpretation of these groups may vary, an open surface is generally characterized by numerous large voids between the aggregate particles. A tight surface has few pores or voids of the size easily penetrated by water or sound. Fine textures are smooth, and consist of small, very closely spaced granular particles. Coarse textures are large grained and rough, and medium textures are, of course, intermediate. Both coarse and medium textures provide better sound absorption than the smoother faces, and are also recommended if the units are to be plastered.

The American Society for Testing and Materials (ASTM) has developed standards to regulate quality and composition. Within the limits of the required structural properties of the masonry, the architect may select different aggregates to serve other nonstructural functions required by building type, occupant use, or aesthetics.

2.2.2 Cements

The cementitious material in concrete masonry is normally Type I, all-purpose portland cement. Type III, high-early-strength cement, is sometimes used to provide early strength and avoid distortion during the curing process. The

air-entraining counterparts of these two cements (Types IA and IIIA) are sometimes used to improve the molding and off-bearing characteristics of the uncured units, and to increase resistance to weathering cycles. Air entrainment, however, does cause some strength reduction.

2.2.3 Admixtures

Admixtures marketed chiefly for use in site-cast concrete have shown few beneficial or desirable effects in the manufacture of concrete masonry. Air entrainment facilitates compaction and the close reproduction of the contours of the molds, but increased air content always results in lower compressive strengths. Calcium chloride accelerators speed the hardening or set of the units, but tend to increase shrinkage. Water repellent admixtures are commonly used in decorative architectural block intended for exterior exposures without protective coatings. However, the bond between mortar and units (and consequently the flexural strength of the wall) will be seriously impaired unless the mortar is also treated with a chemically compatible admixture. ASTM Standards do not permit the use of any admixtures in concrete masonry without laboratory tests or performance records which prove that the additives are in no way detrimental to the performance of the masonry.

Architectural concrete masonry units are sometimes treated with an integral water-repellent admixture during manufacture to resist soil accumulations and to decrease surface water absorption. Some research indicates that calcium stearate-based products are more effective in creating hydrophobic surfaces than those based on oleic/linoleic acid chemistries, and are also less likely to leach out of the masonry. An integral water repellent which lasts the life of the masonry will provide more economical performance than a surface-applied water repellent which must be reapplied every few years. Whenever an integral water repellent is used in a concrete masonry product, compatibility and bond with mortar must be considered because the bonding characteristics of the unit are affected. CMU products that have been treated with an integral water repellent require mortar that has a compatible chemical admixture to promote better bond.

Special colors can be produced by using pure mineral oxide pigments, but many factors affect color consistency. Even in natural block, color variations can be caused by the materials, processing, curing, and weathering. In integrally colored units, such variations may be magnified. Natural aggregate colors are more durable, and more easily duplicated in the event of future additions to a building.

2.2.4 Manufacturing

Concrete masonry manufacturing consists of six phases: (1) receiving and storing raw materials, (2) batching and mixing, (3) molding unit shapes, (4) curing, (5) cubing and storage, and (6) delivery of finished units (see Fig. 2-6).

2.2.5 Material Preparation

Materials are delivered in bulk quantities by truck or rail. Aggregates are stored separately and later blended to produce different block types. Mixes will vary depending on aggregate weight, particle characteristics, and water absorp-

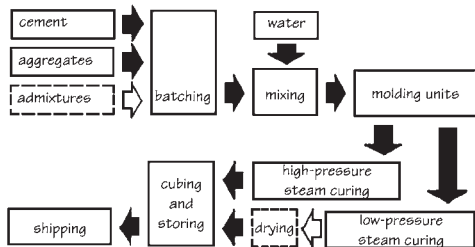


Figure 2-6 Concrete masonry manufacturing process.

tion properties. Ingredients must be carefully regulated so that consistency in texture, color, dimensional tolerances, strength, and other physical properties is strictly maintained. Batching by weight is more common than volume proportioning.

The mixes normally have a low water-cement ratio, and are classified as zero-slump concrete. Special high-strength units are made with more cement and water, but still have no slump. In the production of some slump block units, the batching is changed so that the mix will slump within controlled limits when the unit is removed from its mold. The soft roll in texture is intended to produce the appearance of a handmade adobe.

2.2.6 Forming

Early block production consisted of hand-tamping the concrete mix into wooden molds. A two-man team could turn out about 80 blocks a day. By the mid-1920s, automatic machines could produce as many as 3000 blocks a day. Today, units are molded with a combination of mechanical vibration and hydraulic pressure, and production is typically in the neighborhood of 1000 units per hour.

2.2.7 Curing

Freshly molded blocks are lightly brushed to remove loose aggregate particles, then moved to a kiln or autoclave for accelerated curing.

A normal 28-day concrete curing cycle is not conducive to the mass production of unit masonry. Experiments in accelerated steam curing were conducted as early as 1908. In addition to hastening the hydration process, steam curing also increases compressive strength, helps control shrinkage, and aids in uniformity of performance and appearance. Both high-pressure and low-pressure curing are used in the industry.

Most of the block manufactured in the United States is produced by *low-pressure steam curing*. The first phase is the holding or preset period of 1 to 3 hours. The units are allowed to attain initial hardening at normal temperatures of 70 to 100°F before they are exposed to steam. During the heating

period, saturated steam is injected to raise the temperature to a maximum of 190°F. The exact time duration and temperature span recommended by the American Concrete Institute (ACI) depend on the composition of the cementitious materials and the type of aggregate used. Once maximum temperature is reached, the steam is shut off and a soaking period begins. Blocks are held in the residual heat and moisture for 12 to 18 hours or until the required compressive strengths are developed. An accelerated drying period may also be used, with the temperature in the kiln raised to evaporate moisture.

The entire cycle is generally accomplished within 24 hours. Compressive strengths of 2- to 4-day-old units cured by low-pressure steam are approximately 90% of ultimate strength compared with only 40% for blocks of the same age cured by 28-day moist sprinkling. Steam-cured units are also characterized by a generally lighter color.

A variation of the low-pressure steam method adds a carbonation phase in which carbon dioxide is introduced into the drying atmosphere to cause irreversible shrinkage. Preshrinking decreases volume changes caused by atmospheric moisture conditions and reduces shrinkage cracking in the wall. Carbonation also increases tensile and compressive strength, hardness, and density of the block.

High-pressure steam curing improves the quality and uniformity of concrete masonry, speeds production, and lowers manufacturing costs. Curing takes place in an autoclave kiln 6 to 10 feet wide and as much as 100 feet long (see Fig. 2-7).

A typical high-pressure curing cycle consists of four phases: preset, temperature rise, constant temperature and pressure, and rapid pressure release. The low-heat preset period hardens the masonry sufficiently to withstand the high-pressure steam. The temperature rise period slowly brings both



Figure 2-7 Loading racks of fresh units into an autoclave for high-pressure steam curing. (Photo courtesy PCA.)

pressure and temperature within the autoclave to maximum levels, where they remain constant for 5 to 10 hours. Temperature is actually the critical curing factor. Pressure is used as a means of controlling steam quality. Rapid pressure release or “blow-down” causes quick moisture loss from the units without shrinkage cracks. For normal-weight aggregates, the cycle produces relatively stable, air-dry blocks soon after removal from the autoclave. Lightweight blocks may require additional time to reach this same air-dry condition.

Blocks cured by high-pressure autoclaving undergo different chemical reactions from those cured at low pressure. They are more stable and less subject to volume change caused by varying moisture conditions. The improved dimensional stability reduces shrinkage cracking in completed wall assemblies.

2.2.8 Surface Treatment

Concrete blocks are sometimes finished with ceramic, organic, or mineral *glazes*. These special finishes are applied after curing, and then subjected to heat treatment. The facings vary from epoxy or polyester resins to specially treated glass silica sand, colored ceramic granules, mineral glazes, and cementitious finishes. The treated surfaces are resistant to water penetration, abrasion, and cleaning compounds, and are very durable in high-traffic areas.

Surface *textures* are applied to hardened concrete blocks in a number of ways. Grinding the unit face produces a smooth, polished finish that highlights the aggregate colors (see Fig. 2-8). Ground faces can be supplementally treated with a wax or clear sealer. Sandblasting a block face exposes the underlying aggregate, adding color, texture, and depth. Split-faced units are produced by splitting ordinary blocks lengthwise. Solid units produce a rough stone appearance, while cored units are used to make split-ribbed block (see Fig. 2-9).



Figure 2-8 Concrete blocks face-ground to expose natural aggregate colors.

2.2.9 Cubing and Storage

Once the masonry units have been cured and dried, and any additional surface treatments have been completed, the blocks are removed from the curing racks and assembled in “cubes.” The cubes are moved to a storage yard where, depending on the curing method used, they may remain in inventory anywhere from a few days to several weeks before they are shipped to a job site.

2.3 MORTAR AND GROUT MATERIALS

Mortar may account for as little as 7% of the volume of a masonry wall, but the role that it plays and the influence that it has on performance and appearance are far greater than the proportion indicates. The selection and use of various mortar ingredients directly affect the performance and bonding characteristics of masonry. It is important to be aware of the materials available and the effects they may have on the overall integrity of the masonry.

The principal components of masonry mortar and grout are cement, lime, sand, and water. Each of these constituents is essential in the performance of the mix. Cement gives the mortar strength and durability. Lime adds workability, water retentivity, and elasticity. Sand acts as a filler and contributes to economy and strength, and water imparts plasticity. To produce high-quality mortar and grout, each of the ingredients must be of the highest quality.

2.3.1 Cements

The Romans used natural pozzolans to give hydraulic setting qualities to mortar. Concrete and mortar are said to be “hydraulic” if they will set and



Figure 2-9 Smooth, split-ribbed, and split-faced concrete block.

harden in water. Natural hydraulic cements were widely manufactured in the late eighteenth and early nineteenth centuries. Natural cement rock was burned in kilns, and the calcined lumps were then ground into a fine powder.

Since its discovery in the early nineteenth century, portland cement has become the most widely used material of its kind. Portland cement is a carefully controlled combination of lime, silica, alumina, and iron oxide. Although production of portland cement is a lengthy and complicated procedure, it consists principally of grinding the raw materials, blending them to the desired proportions, and burning the mix in a rotary kiln until it reaches incipient fusion and forms clinkers. These hardened pellets are ground with gypsum, and the fine powder is then bagged for shipment. When mixed with water, portland cement undergoes hydration—a change in the chemical composition of the ingredients in which crystals of various complex silicates are formed, causing the mass to harden and set.

There are five types of portland cement, each with different physical and chemical characteristics. Since the properties required for mortar are significantly different from the qualities called for in concrete, not all of these types are suitable for masonry construction. For most ordinary mortars, Type I, all-purpose cement, is most widely used. In some instances, such as masonry catch basins or underground drainage structures where mortar may come in contact with sulfates in the soil, Type II portland cement can be used to resist chemical attack. A more common substitute for Type I is Type III, high-early-strength cement. This mixture attains ultimate compressive strength in a very short period of time, and generates greater heat during the hydration process. For use in cold weather construction, these properties help keep the wet mortar or grout from freezing and permit a reduction in the period of time required for protection against low temperatures.

Air-entraining portland cement, Types IA, IIA, IIIA, and so on, is made by adding selected chemicals to produce minute, well-distributed air bubbles in the hardened concrete or mortar. Increased air content improves workability, increases resistance to frost action and the scaling caused by chemical removal of snow and ice, and enhances moisture, sulfate, and abrasion resistance. Air-entrained mixes are not as strong as ordinary portland cement mixes, and excessive air is detrimental in mortar and grout because it impairs bond to masonry units and reinforcing steel.

Air-entrained cements are used primarily in horizontal concrete applications where exposure to ponded water, ice, and snow is greatest. Entrained air produces voids in the concrete into which freezing water can expand without causing damage. Rigid masonry paving applications installed with mortared joints may also enjoy some of the benefits of air-entrained cements in resisting the expansion of freezing water. Although industry concrete for masonry mortar generally limit the air content of mortar, the benefits of higher air content in resisting freeze-thaw damage may outweigh the decrease in bond strength. Since rigid masonry paving systems are generally supported on concrete slabs, the flexural bond strength of the masonry is less important than its resistance to weathering. In these applications, lower bond strength might be tolerated in return for increased durability.

2.3.2 Lime

The term “lime” when used in reference to building materials means a burned form of lime derived from the calcination of sedimentary limestone.

Powdered, hydrated lime is the most common and convenient form used today. Of the two types of hydrated lime covered in ASTM C207, *Standard Specification for Hydrated Lime for Masonry Purposes*, only Type S is suitable for masonry mortar because of its ability to develop high early plasticity and higher water retentivity, and because of limits on the unhydrated oxide content (see Fig. 2-10).

The mortar used in most historic buildings was made with lime and sand only and did not contain any cement. However, lime mortars cured very slowly. The invention of portland cement in the early 1800s changed the way mortar was made by substituting cement in the mix for a portion of the lime. Contemporary cement and lime mortars are now made with a higher proportion of cement than lime. Although this has reduced curing time and speeded up construction, the trade-off is that the higher the portland cement content, the stiffer the mixture is when it is wet and the more rigid the mortar when it is cured. A cement mortar without lime is stiff and unworkable and high in compressive strength, but weak in bond and other required characteristics. The continued use of lime, although reduced in proportion, has many beneficial effects in masonry mortar and grout. Lime increases water retentivity, improves workability, and makes the cured mortar or grout less brittle and less prone to shrinkage.

Lime adds plasticity to mortar, enabling the mason to spread it smoothly and fill joints completely, improving both productivity and workmanship. The plastic flow quality of lime helps mortar and grout to permeate tiny surface indentations, pores, and irregularities in the masonry units and develop a strong physical bond. Lime also improves water retention. The mortar holds its moisture longer, resisting the suction of dry, porous units so that sufficient water is maintained for proper curing and development of good bond. Lime has low efflorescing potential because of its relatively high chemical purity. Its slow setting quality allows retempering of a mix to replace evaporated moisture. Lime undergoes less volume change or shrinkage than other mortar ingredients. It contributes to mortar integrity and bond by providing a measure of autogenous healing, the ability to combine with moisture and

- Type N Normal hydrated lime for masonry purposes.
- Type S Special hydrated lime for masonry purposes.
- Type NA Normal air-entraining hydrated lime for masonry purposes.
- Type SA Special air-entraining hydrated lime for masonry purposes.

Property	Type N	Type NA	Type S	Type SA
Calcium and magnesium oxides (minimum %)	95	95	95	95
Carbon dioxide (maximum %)				
If sample is taken at place of manufacture	5	5	5	5
If sample is taken at any other place	7	7	7	7
Unhydrated oxides (maximum %)	—	—	8	8
Plasticity of putty when tested within 30 minutes after mixing with water	—	—	200	200
Water retention after suction for 60 seconds (%)	75	75	85	85

Figure 2-10 ASTM C207 requirements for masonry lime. (Copyright ASTM, 100 Barr Harbor Drive, West Conshohocken, PA 19428. Reprinted with permission.)

carbon dioxide to reconstitute or reknit itself if small cracks develop. Some manufacturers preblend portland cement and lime, and sell bagged mixes that require only the addition of sand and water at the job site.

2.3.3 Masonry Cements and Mortar Cements

Proprietary mixes of cement and workability agents, or “masonry cements,” are popular with masons because of their convenience and good workability. However, ASTM C91, *Standard Specification for Masonry Cement*, places no limitations on chemical composition, and the ingredients as well as the properties and performance vary widely among the many brands available. Although the exact formula is seldom disclosed by the manufacturer, masonry cements generally contain combinations of portland cement, plasticizers, and air-entraining additives. Finely ground limestone, clay, and lime hydrate are often used as plasticizers because of their ability to adsorb water and thus improve workability. Air-entraining additives protect against freeze-thaw damage and provide some additional workability. ASTM C91 limits air content to a range of 8 to 21% (see Fig. 2-11), and sets water retentivity at a minimum of 70%.

Like all proprietary products, different brands of masonry cements will be of different qualities. Because of the latitude permitted for ingredients and proportioning, the properties of a particular masonry cement cannot be accurately predicted solely on the basis of compliance with ASTM standards. They must be established through performance records and laboratory tests.

Mortar cements are also proprietary products, but they must meet higher performance standards than masonry cements (see Fig. 2-12). ASTM C1329, *Standard Specification for Mortar Cement*, permits a maximum air content of 16% for mortars made with mortar cement, and also prescribes minimum flexural bond strength (refer to Chapter 6).

Property	Physical Requirements		
	Masonry Cement Type		
	Type N	Type S	Type M
Fineness, residue on a No. 325 sieve (maximum %)	24	24	24
Autoclave expansion (maximum %)	1.0	1.0	1.0
Time of setting, Gillmore method (minutes)			
initial set not less than	120	90	90
final set not more than	1,440	1,440	1,440
Compressive strength (psi), average of 3 cubes, [‡] equal to or higher than the values specified for the ages indicated below:			
7 days	500	1,300	1,800
	900	2,100	2,900
Air content of mortar, prepared and tested in accordance with requirements of ASTM C91			
minimum (% volume)	8	8	8
maximum (% volume)	21	19	19
Water retention value (minimum % of original flow)	70	70	70

[‡] Mortar cubes composed of 1 part cement and 3 parts blended sand (half graded standard sand and half standard 20-30 sand) by volume, prepared and tested in accordance with ASTM C91.

Figure 2-11 ASTM C91 requirements for masonry cements. (Copyright ASTM, 100 Barr Harbor Drive, West Conshohocken, PA 19428. Reprinted with permission.)

2.3.4 Sand

Sand aggregate accounts for at least 75% of the volume of masonry mortar and grout. Manufactured sands have sharp, angular grains, while natural sands obtained from banks, pits, and river beds have particles that are smoother and more round. Natural sands generally produce mortars that are more workable than those made with manufactured sands.

For use in masonry mortar and grout, sand must be clean, sound, and well graded according to requirements set by ASTM C144, *Standard Specification for Aggregate for Masonry Mortar* (see Fig. 2-13), or ASTM C404, *Standard Specification for Aggregates for Masonry Grout* (see Fig. 2-14). Sand particles should always be washed and treated to remove foreign substances. Silt can cause mortar to stick to the trowel, and can impair proper bond of the cementitious material to the sand particles. Clay and organic substances reduce mortar strength and can cause brownish stains varying in intensity from batch to batch.

The sand in masonry mortar and grout acts as a filler. The cementitious paste must completely coat each particle to lubricate the mix. Sands that have a high percentage of large grains produce voids between the particles, and will make harsh mortars with poor workability and low resistance to moisture penetration. When the sand is well proportioned of both fine and coarse grains, the smaller grains fill these voids and produce mortars that are more workable and plastic. If the percentage of fine particles is too high, more cement is required to coat the particles thoroughly, more mixing water is required to produce good workability, and the mortar will be weaker, more porous, and subject to greater volume shrinkage.

Property	Physical Requirements		
	Mortar Cement Type		
	Type N	Type S	Type M
Fineness, residue on a No. 325 sieve (maximum %)	24	24	24
Autoclave expansion (maximum %)	1.0	1.0	1.0
Time of setting, Gillmore method (minutes)			
initial set not less than	120	90	90
final set not more than	1,440	1,440	1,440
Compressive strength (psi), average of 3 cubes, [§] equal to or higher than the values specified for the ages indicated below:			
7 days	500	1,300	1,800
28 days	900	2,100	2,900
Flexural bond strength, 28 days, minimum (psi)	70	100	115
Air content of mortar, prepared and tested in accordance with requirements of ASTM C91			
minimum (% volume)	8	8	8
maximum (% volume)	16	14	14
Water retention value (minimum % of original flow)	70	70	70

[§] Mortar cubes composed of 1 part cement and 3 parts blended sand (half graded standard sand and half standard 20-30 sand) by volume, prepared and tested in accordance with ASTM C91.

Figure 2-12 ASTM C1329 requirements for mortar cements. (Copyright ASTM, 100 Barr Harbor Drive, West Conshohocken, PA 19428. Reprinted with permission.)

ASTM C144 Sand Gradation Requirements [‡]		
Sieve Size	Percent Passing	
	Natural Sand	Manufactured Sand
4	100	100
8	95 to 100	95 to 100
16	70 to 100	70 to 100
30	40 to 75	40 to 75
50	10 to 35	20 to 40
100	2 to 15	10 to 25
200	0 to 5	0 to 10

[‡] Not more than 50% shall be retained between any two sieve sizes nor more than 25% between No. 50 and 100 sieve sizes.

[†] If an aggregate does not meet the gradation requirement limits, it may be used if the mortar meets the property specification of ASTM C270.

Figure 2-13 ASTM C144 requirements for masonry mortar sand. (Copyright ASTM, 100 Barr Harbor Drive, West Conshohocken, PA 19428. Reprinted with permission.)

Sieve Size	Amounts Finer Than Each Laboratory Sieve (weight %)				
	Fine Aggregate			Coarse Aggregate	
	Size No. 1	Size No. 2		Size No. 8	Size No. 89
		Natural	Manufactured		
1/2 inch	—	—	—	100	100
3/8 inch	100	—	—	85 to 100	90 to 100
4	95 to 100	100	100	10 to 30	20 to 55
8	80 to 100	95 to 100	95 to 100	0 to 10	5 to 30
16	50 to 85	70 to 100	70 to 100	0 to 5	0 to 10
30	25 to 60	40 to 75	40 to 75	—	0 to 5
50	10 to 30	10 to 35	20 to 40	—	—
100	2 to 10	2 to 15	10 to 25	—	—
200	0 to 5	0 to 5	0 to 10	—	—

Figure 2-14 ASTM C404 requirements for masonry grout aggregate. (Copyright ASTM, 100 Barr Harbor Drive, West Conshohocken, PA 19428. Reprinted with permission.)

Figure 2-15 illustrates the range and distribution of particle gradation that are acceptable under ASTM C144, from the coarsest allowable gradation to the finest allowable gradation, with the ideal gradation shown in the middle. Both the coarse and fine gradations have a void content much higher than that of the ideal gradation. Many commercially available sands fall out-

side of ASTM gradation requirements for mortar and may have void contents even larger than those shown. Such shortcomings may be corrected by the addition of the deficient fine or coarse sands.

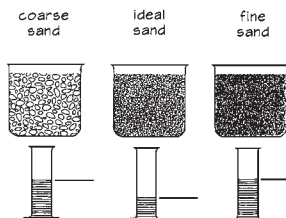
When locally available mason's sand does not meet ASTM C144 gradation requirements, it can still be used if laboratory tests determine that a mortar can be produced that meets the property specification requirements of ASTM C270, *Standard Specification for Mortar for Unit Masonry*. The volume ratio of aggregate to cementitious materials may be selected and tested at various levels within the specified range of 2½ to 3½ times the sum of the volume of the cementitious materials. If test results show that ASTM C270 property requirements for compressive strength, air content, and water retentivity are met, the aggregate is qualified for use at the tested ratio.

2.3.5 Water

Water for masonry mortar must be clean and free of harmful amounts of acids, alkalis, and organic materials. Whether the water is drinkable is not in itself a consideration, as some drinking water contains appreciable amounts of soluble salts, such as sodium and potassium sulfate, which can contribute to efflorescence. If necessary, laboratory analysis of the water supply should be used to verify suitability.

2.3.6 Mortar Admixtures

Although admixtures are often used with some success in concrete construction, they can have adverse effects on the properties and performance of masonry mortar and grout. ASTM mortar standards do not incorporate, nor in fact even recognize, admixtures of any kind.



The level of liquid in the cylinders represents the volume of voids in the sand mixture. A sand with the ideal mix of coarse and fine grains (complying with ASTM C 144 gradation limits) has a lower volume of voids and is therefore more economical because it requires less cementitious material to properly coat the particles.

Figure 2-15 Sand gradation for masonry mortar. (From *Portland Cement Association, Trowel Tips—Mortar Sand*.)

A variety of proprietary admixtures are available that are reported by their manufacturers to increase workability or water retentivity, lower the freezing point, and accelerate or retard the set. Although they may produce some effects, they can also reduce compressive strength, impair bond, contribute to efflorescence, increase shrinkage, or corrode metal accessories and reinforcing steel. If admixtures are permitted to produce or enhance some special property in the mortar, the specifications should require that they meet the requirements of ASTM C1384, *Standard Specification for Modifiers for Masonry Mortar* (see Fig. 2-16).

Also ask the manufacturer for test data that reports performance under field conditions. Tests done in a laboratory at 73°F do not necessarily reflect how an admixture will perform on the job site at 40°F. If relevant data is scarce, test the admixture at an independent laboratory and determine exact dosage rates with the materials which will be used at the job site. Make sure the mortar still meets ASTM specification requirements, and that the admixture does not contribute to other problems such as efflorescence or corrosion of embedded metals. Request and retain test results that support the manufacturer's claims.

Several proprietary *plasticizers* or *workability enhancers* are sold to partially or wholly replace lime in masonry mortar and grout. One plasticizer used as a complete lime replacement contains, among other ingredients, natural bentonite clay as a lubricant. The water-carrying capacity of the clay gives mortar a longer board life than conventional portland-lime or masonry cement mortars.

Other types of plasticizing agents work by changing the viscosity of the mixing water and its evaporation rate, or by modifying the cement reaction rate. This increased workability can be beneficial in relatively stiff, high-compressive-strength mixes.

Physical Requirements for Modified Mortars (In Addition to ASTM C270 Mortar Requirements)					
Property	Bond Enhancer	Workability Enhancer	Set Accelerator	Set Retarder	Water Repellent
Minimum compressive strength (% of reference)					
7 day	80	80	80	70	80
28 day	80	80	80	80	80
Minimum water retention (% of reference)	report*	100	report*	report*	report*
Air content of plastic mortar	report*	report*	report*	report*	report*
Minimum board life (% of reference)	report*	120	report*	120	report*
Time of setting, allowable deviation from reference (hr:min)					
Initial set: at least	—	—	1:00 earlier	1:00 later	—
not more than	1:00 earlier nor 1:30 later	1:00 earlier nor 3:30 later	3:30 earlier	8:00 later	1:00 earlier nor 1:30 later
Final set: at least	—	—	1:00 earlier	—	—
not more than	1:00 earlier nor 1:30 later	1:00 earlier nor 3:30 later	—	8:00 later	1:00 earlier nor 1:30 later
Minimum flexural bond strength (% of reference)	110	—	—	—	—
Maximum rate of water absorption (% of reference, 24 hr.)	—	—	—	—	50

* Report test results.

Figure 2-16 ASTM C1384 modifiers for masonry mortar. (Copyright ASTM, 100 Barr Harbor Drive, West Conshohocken, PA 19428. Reprinted with permission.)

Air-entraining agents help hardened mortar resist freeze-thaw damage and improve the workability of wet mortar by creating minute air bubbles in the mix. In hardened mortar, freezing water expands into these air pockets instead of building up pressure, which might otherwise fracture the mortar. In wet mixes, the bubbles act as a lubricant and a water reducer to increase workability and significantly lower water content. Air entrainment may be useful whenever the hardened mortar will be exposed to freeze-thaw cycles in the presence of moisture (such as paver installations). During cold weather, air entrainment may also be helpful because the lower water content of the mortar offers less potential for freezing before set.

Neutralized vinsol resins are used most widely in air-entraining admixtures, but organic acid salts, fatty acids, and hydrocarbon derivatives are also used. Although job-site admixtures are available, air-entraining agents should not be added in the field, because it is difficult to obtain a consistent air content. Instead, air-entrained portland cement or masonry cements, or air-entrained lime, should be used, so that the batching is premeasured. Excess air entrainment decreases both compressive strength and bond strength. ASTM C270 limits the air content of masonry mortars and prohibits the use of more than one air-entrained ingredient in a mix (see Chapter 6).

Set accelerators are sometimes used in winter construction to speed cement hydration, shorten setting time, increase 24-hour strength, and reduce the time required for cold weather protective measures. *Water-reducing accelerators* increase early strength and ultimate strength by reducing the water-cement ratio needed to produce a workable mix. Set accelerators, sometimes mistakenly referred to as “antifreeze” compounds, contain calcium chloride, calcium nitrite, calcium nitrate, calcium formate, or other aqueous solutions of organic and inorganic polymer compounds such as soluble carbonates, silicates and fluoroalicates, calcium aluminates, and triethanolamine. Accelerators are added to the mortar mixing water as a percentage of the weight of the cement.

Calcium chloride and other chloride ions contain salts that can contribute to efflorescence. Calcium chloride and, to a lesser extent, calcium nitrate also cause corrosion of embedded steel anchors and reinforcement. Non-chloride accelerators are a little more expensive, but less damaging to the masonry. Chlorides should be prohibited in mortar and grout that contain embedded metals such as anchors, ties, or joint reinforcement. Triethanolamine (TEA) and calcium aluminate accelerators should also be prohibited because of ultimate strength reductions and flash setting problems. Automotive antifreeze should never be used in masonry mortar or grout.

Set retarders extend the board life of fresh mortar and grout for as long as 4 to 5 hours by helping to retain water for longer periods of time. Set retarders, which contain sodium gluconate, sodium lignosulfonate, or sodium citrate, are sometimes used during hot weather to counteract the effects of rapid set and high evaporation rates. With soft, dry brick or block, set retarders are also sometimes used to counteract rapid suction and help achieve better bond. Mortar with set retarders *cannot* be retempered.

Extended-life retarders slow the hydration of the cement and water to give the mortar a 12- to 72-hour board life, depending on the dosage rate. The extended workability allows the mortar to be mixed at a central batching plant where quality control can be closely maintained, and then shipped to the site in plastic tubs. The admixture has little or no effect on setting time, because the retarder is absorbed by the masonry units on contact, allowing normal cement hydration to begin. The extended-life retarders used in ready-mixed mortars contain hydroxycarboxylic acids and other ingredients. Hot weather may require higher dosage rates. Most extended-life retarders

increase air content in the mortar slightly, so use with other air-entrained mortar ingredients should be very carefully controlled or avoided entirely.

Bond enhancers are intended to improve adhesion to smooth, dense-surfaced units such as glass block. Made of acrylic polymer latex, polyvinyl acetate, styrene butadiene rubber, or methol cellulose, bond modifiers cannot be used with air-entraining agents or air-entrained cements.

In marine environments or where deicing salts may be used, calcium nitrite *corrosion inhibitors* are used to offset the effects of chloride intrusion and prevent steel reinforcement and anchors from corroding. Corrosion inhibitors may also accelerate setting time and reduce entrained air content.

Integral water repellents reduce the water absorption of hardened mortar by as much as 60%. They are typically used in conjunction with architectural concrete masonry units that have also been treated with an integral water repellent admixture. Stearate-, fatty acid-, or polymeric-based water repellents reduce the capillarity of the mortar while still permitting moisture vapor transmission. Using water-repellent-treated mortar with untreated masonry units, or vice versa, can reduce mortar-to-unit bond and the flexural strength of the wall. Reduced bond can negate the effects of the water repellent by allowing moisture to penetrate the wall freely at the joint interfaces. Mortars and block treated with integral water repellents achieve better bond and better moisture resistance only if the admixtures are chemically compatible. Wall panels should be tested both for flexural bond strength and water permeance compared to an identical but untreated wall.

Some integral water repellents based on fatty acids or stearates other than calcium stearate perform satisfactorily only for a limited time. Solvent migration eventually renders the treatment ineffective. Obtain manufacturer's test data on long-term performance to verify that the service life of the product is commensurate with the expected service life of the masonry.

2.3.7 Mortar Colors

Natural and synthetic *pigments* are used to color masonry mortar (see Fig. 2-17). Most mortar colorants are made from iron oxide pigments. Iron oxides are nontoxic, colorfast, chemically stable in mortar, and resistant to ultraviolet radiation. Iron oxides come in yellows, reds, browns, and blacks. Chromium oxides (which produce greens) and cobalt (which produces blue) also are stable in alkalis and resist ultraviolet radiation. Ultramarine blues, which are made from sulfur, sodium carbonate, and kaolin, are less stable in mortar. Carbon black and lampblack (used to make blacks and browns) are less weather resistant than the iron oxides used to make the same colors.

Iron oxide pigments are either natural or synthetic. Natural iron oxides are made by crushing and grinding iron ore to a fine particle size. Synthetic iron oxides are made by several processes, including precipitation of iron salts, calcination of iron salts, and as a by-product in the manufacture of aniline, which is used in dyes. Synthetic iron oxides have more tinting power, so less pigment is required per unit of mortar to produce a given color. Synthetic oxides also produce brighter, cleaner colors than natural iron oxides. Natural and synthetic pigments may also be blended together.

Beyond a certain point, called the saturation point, the color intensity of the mortar does not increase in proportion to the amount of pigment added. The saturation point varies, depending on the tinting strength of the particular pigment. Synthetic iron oxides generally are saturated at about 5% of the weight of the cement, and natural oxides at about 10%. Adding pigment beyond the saturation point produces little additional color.

Concrete or Mortar Color [‡]	Pigments Used [†]
Black, Gray	Black iron oxide, mineral black, carbon black
Brown, Red	Red iron oxide, brown iron oxide, raw umber, burnt umber
Rose, Pink	Red iron oxide (varying amounts)
Buff, Cream, Ivory	Yellow ochre, yellow iron oxide
White	White cement and white sand (no pigments required)
Green	Chromium oxide, phthalocyanine green
Blue	Cobalt blue, ultramarine blue, phthalocyanine blue

[‡] Color of finished concrete and mortar is affected by color of cement and aggregates.

[†] Synthetic iron oxides have more tinting power than natural iron oxides, so less pigment is required per unit of concrete or mortar to produce a given color. Synthetic oxides also produce brighter, cleaner colors.

Figure 2-17 Concrete and mortar coloring pigments.

When pigments are used in recommended dosages, colored mortar has not been found to adversely affect the compressive strength of the masonry, but bond strength is reduced by 3 to 5%. Colored mortar can be made at the job site from powdered or liquid pigments. Powdered pigments are used most frequently, and the majority are packaged so that one bag contains enough pigment to color 1 cu ft of cementitious material (i.e., for each 1-cu ft bag of masonry cement, portland cement or lime, one bag of color is added). Pigment manufacturers supply charts that identify the exact number of bags of pigment required for various mortar proportions. Similarly, liquid colorants are generally packaged so that 1 qt of pigment is needed for each bag of cementitious material. Manufacturers can also custom blend and package pigment so that one bag or bottle contains enough colorant for an entire batch of mortar. Liquid pigments create less mess and blowing dust than dry powders, but they also cost more. The same pigments used to color mortars are used to produce colored concrete masonry units. Some manufacturers market colored masonry cements, mortar cements, and prebagged portland lime-mortar mixes in which pigments are preblended in the bag with the other ingredients.

The color of a finished mortar joint is affected by the properties of the component materials, including the sand aggregate and cement, the workmanship, curing conditions, cleaning procedures, joint type, and joint tooling techniques. When colored mortar is used, it is best to evaluate and select materials on the basis of samples that closely approximate job-site materials and design, and to incorporate the colored mortar into a job-site sample panel before acceptance.

2.3.8 Grout Admixtures

Shrinkage-compensating admixtures (commonly called grouting aids) are the most common grout additives. Grout typically shrinks 5 to 10% after placement as the surrounding masonry units absorb water. To minimize volume loss, maintain good bond, and give workers more time to vibrate the grout

before it stiffens, these specially blended admixtures expand the grout, retard its set, and lower the water requirements. Admixtures can also be used to accelerate set in cold weather or retard set in hot weather. Superplasticizers may also be used in hot weather to increase slump without adding water or reducing strength. All grout mixes that contain admixtures should be tested in advance of construction to assure quality. Grout mix designs that meet project requirements and ASTM guidelines can be determined in the laboratory by preconstruction testing of trial batches.

The table in *Fig. 2-18* lists the types of admixtures most commonly used in masonry grout. Air-entraining admixtures for increased freeze-thaw durability are used less frequently because the grout is normally not exposed to moisture saturation.

2.4 ENVIRONMENTAL IMPACT

Environmental issues are a growing concern in the construction industry. New terms like “green buildings,” “sustainable architecture,” “embodied energy,” and “building ecology” have crept into the vocabularies of architects, owners, and contractors alike. Ecological issues are being driven beyond the philosophical and ideological into the mainstream of business economics. The cost of energy, the cost of raw materials, and the cost of solid waste and hazardous waste disposal are directly linked to profitability in any industry. The operational efficiency of buildings and occupant productivity also have a direct effect on overhead and profit as well as health.

ASTM’s Subcommittee E50.06 on Green Buildings defines that term as “building structures...that are designed, constructed, operated and demolished in an environmentally enhanced manner.” That means using recycled materials wherever possible, and avoiding materials that create the clinical symptoms of “sick building syndrome.” Areas of particular concern include resource efficiency, energy efficiency, pollution control, waste minimization, and indoor air quality.

The concepts of green buildings and sustainable architecture are so new that guidelines are only now being developed. Generally, a building is evaluated throughout its life cycle, from construction through operation and demolition. The amount of energy consumed and the amount of waste generated at each phase, as well as the building’s internal environment and its relationship to the external global environment, should enter into site considerations, design decisions, and product selections.

Type of Admixture	Uses
Shrinkage compensating	Expands grout to compensate for moisture shrinkage
Set retarding	Delays set during hot weather, long transit, or time delays
Set accelerating (noncorrosive)	Accelerates set during cold weather
Corrosion inhibiting	Reduces corrosion in harsh environments
Superplasticizing	Increases slump without additional water and without strength reduction
Antifreeze compound	THERE IS NO SUCH THING AS AN “ANTIFREEZE” ADMIXTURE

Figure 2-18 Chemical admixtures for masonry grout.

The green building movement seeks to identify building materials that minimize environmental impacts in their creation and use, and minimize health risks to building occupants. But there is no such thing as an environmentally perfect material. Product selection for green buildings is therefore a process of evaluation and compromise, seeking the best overall solution for a given program and budget. For example, steel may have more embodied energy than wood, but steel framing is more efficient and can produce smaller structural members and longer spans. Ceramic tile is more energy intensive than hardwood for flooring, but requires no finish coatings and no chemical cleaners for maintenance. By the same token, masonry products may require more energy to produce than some other building materials, but their performance characteristics, durability, and chemical stability usually justify similar trade-offs.

Masonry's multi-functional properties have always made it an attractive choice as a building material. From an environmental standpoint, this ability to serve more than one purpose is a particular bonus. Coatings are generally not required because most types of masonry already have a finished surface. Sound batts are not required because the masonry has inherent sound-damping capacity. Fireproofing is not required because masonry is non-combustible. And structural framing is eliminated in buildings where loadbearing systems can be used. The thermal mass of masonry can reduce the amount of insulation material required in some climates. It can also, when properly integrated with passive solar design techniques, reduce total energy consumption and reduce utility service demand through off-peak loading. Such multi-functional applications, as well as the long service life and low maintenance traditionally associated with masonry buildings, mean that the energy embodied in the materials goes further, and delivers more than many other materials.

Two of the premier examples typically cited for their environmentally responsible design are the Audubon Society Headquarters in New York and the Natural Resources Defense Council Building in Washington, both designed by the Croxton Collaborative architects. One thing the two have in common is their adaptive reuse of historic masonry buildings. The rehabilitation of historic buildings, many of which are masonry, conserves the embodied energy already invested in such structures.

Products and systems must demonstrate reduced life-cycle energy consumption, increased recycled content, and minimal waste products in manufacture, construction, use, and demolition. Such requirements may result in the introduction of mortarless interlocking masonry systems, a renewed interest in "bio-bricks," or the successful reintroduction of autoclaved cellular concrete block from Europe.

2.4.1 Resource Management, Recycled Content, and Embodied Energy

The raw materials for making clay brick are an abundant resource that is easily acquired and produces little waste. Clay-mining operations are regulated by the Environmental Protection Agency, and dormant pits have been reclaimed as lakes, landfills, and nature preserves. Recycled materials are not often used in the manufacture of clay brick, but additives such as oxidized sewage sludge, incinerator ash, fly ash, waste glass, paper-making sludge, and metallurgical wastes have been incorporated with varying degrees of success. The waste materials are either burned to complete combustion at the high kiln temperatures needed to bake the brick, or encapsulated within the clay body where they cannot leach out. The primary energy cost associated with brick manufacturing is the fuel burned in the firing process.

Most brick kilns now use natural gas instead of coal. This has reduced sulfur dioxide emissions and also allows more precise control of fuel consumption. Waste heat from the firing kilns is also ducted and reused to dry unfired units. When the costs of transporting brick to job sites is factored in, the embodied energy is estimated at approximately 4000 Btu per pound of brick.

The primary ingredients in concrete masonry units are the sand and aggregates, which account for as much as 90% of a unit's composition. These materials are abundant, easily extracted, and widely distributed geographically. Recycled materials such as crushed concrete or block and by-products such as blast furnace slag, cinders, and mill scale can be used for some of the aggregate. The portland cement used as the binder in concrete masonry is energy intensive in its production, but it accounts for only about 9 to 13% of the unit. Energy consumption for cement production has decreased 25% during the last 20 years, mostly as a result of more efficient equipment and production methods. The proportion of portland cement in concrete masonry units can be reduced by substituting fly ash, which is a by-product of coal-fired power plants.

Natural stone uses less energy in its production and fabrication than other masonry materials, but its transportation costs can be significantly higher. It is not unusual for a stone to be quarried on one continent, shipped to another for fabrication, and to yet another for installation. The use of local or regional building stones greatly reduces transportation and embodied energy costs.

2.4.2 Construction Site Operations

Masonry construction is generally less hazardous to the environment than some other building systems because most of the materials used are chemically inert. Mortar-mixing and stone-cutting operations can generate airborne particulate wastes such as silica dust. Keeping aggregate piles covered and using water-cooled saws can reduce this hazard. Modular dimensioning of masonry can reduce job-site waste by limiting construction to the use of only whole and half-size units.

Cleaning compounds, mortar admixtures, coatings, and the chemicals used to clean and maintain equipment may include potentially hazardous materials. Precautions should be taken in the disposal of such products, and runoff should be controlled to prevent the migration of chemicals into natural waterways and municipal storm sewer systems. On small cleaning projects, this may be a simple matter of temporary flashings and catch basins, but on large projects this may become a complex task. The rinse material should be tested after cleaning a sample wall area to make sure it is safe to dispose of in the public storm sewer system.

2.4.3 Indoor Air Quality/Building Ecology

When the cost of energy went up dramatically in the 1970s, building standards began to change. Construction was tightened up to reduce or eliminate air leakage and the heat loss or heat gain associated with it. Ventilation standards also changed, reducing the number of air changes per hour that the mechanical systems delivered to increase the efficiency of heating and cooling systems. Unfortunately, these changes also led to increased concentrations of chemical air pollutants in buildings. Many building products contain substances that are known to pose health risks through continued exposure. Substances used in the manufacture of plywood, insulation, sealants, adhesives, paints, pigments, and solvents include formaldehyde and benzenes (both of which are carcinogens), as well as trichloroethylene.

Synthetic carpet can emit formaldehyde, toluene, and xylene as well as methyl methacrylate, ethylbenzene, and a host of other chemicals. Even softwood framing lumber contains terpenes that continually offgas and are of concern for sensitive individuals. Masonry products are generally inert and do not contribute to indoor air quality problems. They contain no toxins or volatile organic compounds (VOCs), do not emit any chemical pollutants as they age, and will not support mold growth, and none of the natural stone that is typically used in building is known to emit radon.

PART **2**

MASONRY PRODUCTS AND ACCESSORIES

This page intentionally left blank.

3

CLAY AND CERAMIC PRODUCTS

Clay as a raw material is most valued for its ceramic characteristics. When subjected to high firing temperatures, the silicates in clay melt, fusing the particles to a density that approaches vitrification. The resulting strength and weather resistance make brick, structural clay tile, and terra cotta among the most durable of building materials.

3.1 BRICK There are many different shapes, sizes, and types of brick. ASTM standards cover building brick, facing brick, hollow brick, paving brick, firebox brick, glazed brick, chemical resistant brick, and others based on appearance of the unit. The three most widely used are building brick, face brick, and hollow brick (see Fig. 3-1).

Building brick (sometimes called common brick) is used primarily as a structural material or as a backing for other finishes, where strength and durability are of more importance than appearance. Under ASTM C62, *Standard Specification for Building Brick*, grading is based on physical requirements and directly related to durability and resistance to weathering (see Fig. 3-2).

Grade SW (severe weathering) is used where a high degree of resistance to frost action is required and where conditions of exposure indicate the possibility of freezing when the unit is permeated with water. Grade SW is recommended for below-grade installations in moderate and severe weathering areas, and for horizontal or other non-vertical surfaces in all weathering conditions. Grade MW (moderate weathering) may be used only in negligible weathering regions for vertical installations and for above-grade non-vertical installations. Grade NW (no weathering) is permitted only for interior work where there will be no weather exposure.

Moisture enters the face of a brick by capillary action. When present in sufficient quantity and for an extended time, water will penetrate through the brick and approximate the laboratory condition defined as “permeated” (which results from 24-hour submersion in cold water). Permeation may easily

Unit	Weathering Grade	Minimum Compressive Strength, Gross Area (psi)		Maximum Water Absorption by 5-Hour Boiling (%)		C/B Maximum Saturation Coefficient	
		Average of 5 Tests	Individual Unit	Average of 5 Tests	Individual Unit	Average of 5 Tests	Individual Unit
Face brick (ASTM C216)	SW	3000	2500	17	20	0.78	0.80
	MW	2500	2200	22	25	0.88	0.90
Building brick (ASTM C62)	SW	3000	2500	17	20	0.78	0.80
	MW	2500	2200	22	25	0.88	0.90
	NW	1500	1250	no limit	no limit	no limit	no limit
Hollow brick (ASTM C652)	SW	3000	2500	17	20	0.78	0.80
	MW	2500	2200	22	25	0.88	0.90
Glazed brick (ASTM C1405)	Exterior	6000	5000	—	7 (cold water)	0.78	0.80
	Interior	3000	2500	—	—	—	—
Glazed brick (ASTM C126)	—	3000	2500	—	—	—	—
	—	2000	1500	—	—	—	—

Grade Recommendations for Brick Exposures in Exterior Walls		
Exposure	Weathering Index	
	Less Than 50	50 and Greater
In vertical surfaces:		
In contact with earth	MW	SW
Not in contact with earth	MW	SW
In other than vertical surfaces:		
In contact with earth	SW	SW
Not in contact with earth	MW	SW

Grade SW Brick intended for use where high and uniform resistance to damage caused by cyclic freezing is desired, and where the brick may be frozen when permeated with water.

Grade MW Brick which may be used where moderate resistance to cyclic freezing damage is permissible or where the brick may be damp but not permeated with water when freezing occurs.

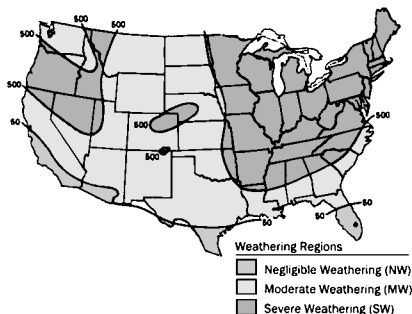


Figure 3-1 ASTM physical requirements for brick. (Copyright ASTM, 100 Barr Harbor Drive, West Conshohocken, PA 19428. Reprinted with permission.)

Brick Grades for Durability

- Grade SW** brick for use where high and uniform resistance to damage caused by cyclic freezing is desired, and where brick may be frozen when saturated with water
- Grade MW** brick for use where moderate resistance to damage caused by cyclic freezing is permissible, or where brick may be damp but not saturated with water when freezing occurs
- Grade NW** brick with little resistance to damage caused by cyclic freezing, but which is acceptable for applications protected from water absorption and freezing

Brick Types for Appearance

- Type FBS and HBS** brick for general use in masonry (traditional or contemporary styles of architecture)
- Type FBX and HBX** brick for general use in masonry where a higher degree of precision and lower permissible variation in size than permitted for Type FBS is required (crisp, linear, contemporary styles of architecture or stack bond patterns)
- Type FBA and HBA** brick for general use in masonry, selected to produce characteristic architectural effects resulting from non-uniformity in size and texture of the individual units (rustic styles of architecture)



Type FBS Brick



Type FBA Brick



Type FBX Brick

Brick	Grade	Type
ASTM C62 Building Brick	SW, MW, NW	N/A
ASTM C216 Face Brick	SW, MW	FBS, FBX, FBA
ASTM C652 Hollow Brick	SW, MW	HBS, HBX, HBA

Figure 3-2 Brick weathering *Grade* and appearance *Type*.

occur in units exposed in parapet walls, retaining walls, and horizontal surfaces, but is unlikely for ordinary exterior wall exposures if the brick is suitably protected at the top by copings, metal flashings, or overhanging eaves. Under most circumstances, permeation of the brick in building walls would result only from defective workmanship or faulty drainage.

Face brick is used for exposed areas where appearance is an important design criteria. These units are typically selected for specific aesthetic criteria such as color, dimensional tolerances, uniformity, surface texture, and limits on the amount of cracks and defects. ASTM C216, *Standard Specification for Facing Brick*, covers Grades SW and MW, which correspond to the same physical and environmental requirements as those for building brick. Within each of these grades, face brick may be produced in three specific appearance types. Type FBS (Standard) is for general use. Type FBX (Select) is for use in exposed applications such as stack bond patterns where a high degree of mechanical perfection and minimum size variation are required. Type FBA (Architectural) is manufactured with characteristic architectural effects, such as distinctive irregularity in size and texture of the individual units to simulate historic brick (see Fig. 3-3). Extruded, stiff-mud brick may be produced in any of the three types by progressively increasing the amount of texturing and roughening the units receive after leaving the die. Dry-press brick normally falls well within the strict tolerances required for Type FBX, but is not widely used because of higher production costs and the higher labor costs associated with laying up such precision units. Soft-mud brick, including hand-molded units, is rustic in appearance and meets the specifications only for Type FBA. Both labor economy and distinctive appearance make FBA brick very popular in residential and light commercial construction. All three types meet the same requirements for strength and durability.

ASTM C216 formerly made reference to color range in describing brick types, but the reference has been dropped in recent editions. Color range used to be associated with size variation when the older kiln types were used. Dark colors indicated hard-burned brick that experienced greater shrinkage during firing than lighter-colored, soft-burned brick. Brick Types FBS, FBX, and FBA differ only in appearance as related to degree of precision and uniformity in size tolerance. Types FBS, FBX, and FBA are all available in a wide range of colors as well as in both weathering Grades SW and MW.

The allowable size tolerances for brick Types FBS and FBX have also been modified in recent editions of ASTM C216, to tighten the allowable size variation within a job lot. The changes are meant to reflect the actual variations in the majority of brick manufactured in the United States, and are based on a survey conducted by the Brick Industry Association.

Used brick is sometimes specified by architects because of its weathered appearance and broad color range. In many instances, these specimens are not totally in compliance with accepted standards of durability for exposed usage. Sources for salvaged masonry are generally buildings at least 30 to 40 years old, constructed of solid masonry walls with hard-burned brick on the exterior and inferior “salmon” brick as backup. Since the color differences used in originally sorting and selecting the brick become obscured with exposure and contact with mortar, salmon brick may inadvertently be used for an exterior exposure, where it can undergo rapid and excessive deterioration. Building code requirements may vary regarding the use of salvaged brick, and should be consulted prior to its selection and specification.

Imported Mexican brick gives a distinctive, handcrafted quality to masonry. It also lacks uniformity in conformance with U.S. durability standards. Officials at the Brick Institute of Texas estimate that as much as 85%

Tolerances on Dimensions								
Specified Dimension (in.)	Maximum Permissible Variation (inches) Plus or Minus From							
	Specified Dimension	Specified Dimension or Average Brick Size in Job Lot Sample		Specified Dimension		Average Brick Size in Job Lot Sample ¹		
	ASTM 62	ASTM C652 Type HBX	ASTM C652 Type HBS and HBB	ASTM C216 Type FBX	ASTM C216 Type FBS	ASTM C216 Type FBX	ASTM C216 Type FBX Smooth [†]	ASTM C216 Type FBX Rough [‡]
3 and under	3/32	1/16	3/32	1/16	3/32	1/16	1/16	3/32
Over 3 to 4	1/8	3/32	1/8	3/32	1/8	1/16	3/32	1/8
Over 4 to 6	3/16	1/8	3/16	1/8	3/16	3/32	3/32	3/16
Over 6 to 8	1/4	5/32	1/4	5/32	1/4	3/32	1/8	1/4
Over 8 to 12	5/16	7/32	5/16	7/32	5/16	1/8	3/16	5/16
Over 12 to 16	3/8	9/32	3/8	9/32	3/8	3/16	1/4	3/8

¹ Lot size as determined by agreement between purchaser and seller. If not specified, lot size is understood to mean all brick of one size and color in the job order.

[†] Type FBS Smooth units have relatively fine texture and smooth edges, including wire cut surfaces.

[‡] Type FBS Rough units have textured, rounded, or tumbled edges or faces.

Tolerances on Distortion				
Maximum Dimension (inches)	Maximum Permissible Distortion (inches)			
	ASTM C216		ASTM C652	
	Type FBX	Type FBS	Type HBX	Type HBS
8 and under	1/16	3/32	1/16	3/32
Over 8 to 12	3/32	1/8	3/32	1/8
Over 12 to 16	1/8	5/32	1/8	5/32

Maximum Permissible Extent of Chippage						
Unit Type	Percentage Allowed ¹	Chippage (in.) in from		Percentage Allowed ¹	Chippage (in.) in from	
		Edge	Corner		Edge	Corner
FBX	5% or less	1/8 to 1/4	1/4 to 3/8	95 to 100%	0 to 1/8	0 to 1/4
FBS Smooth	10% or less	1/4 to 5/16	3/8 to 1/2	90 to 100%	0 to 1/4	0 to 3/8
FBS Rough	15% or less	5/16 to 7/16	1/2 to 3/4	85 to 100%	0 to 5/16	0 to 1/2
FBA	To meet designated sample or as specified by purchaser, but not more restrictive than Type FBS rough					
HBX	5% or less	1/8 to 1/4	1/4 to 3/8	95 to 100%	0 to 1/8	0 to 1/4
HBS Smooth	10% or less	1/4 to 5/16	3/8 to 1/2	90 to 100%	0 to 1/4	0 to 3/8
HBS Rough	15% or less	5/16 to 7/16	1/2 to 3/4	85 to 100%	0 to 5/16	0 to 1/2
HBA and HBB	To meet designated sample or as specified by purchaser, but not more restrictive than Type HBS rough					

¹ Percentage of exposed brick allowed in wall with chips measured the listed dimension in from an edge or corner.

Figure 3-3 Brick manufacturing tolerances. (Copyright ASTM, 100 Barr Harbor Drive, West Conshohocken, PA 19428. Reprinted with permission.)

of the imported brick sold in that state each year is found to be substandard in water absorption, weathering, and compression tests. The abbreviated burning period and low firing temperatures typical of some Mexican brick plants produce units that are extremely soft and porous, causing severe maintenance problems even in relatively dry climates (see Fig. 3-4).



Figure 3-4 Substandard brick. (Photos courtesy Brick Institute of Texas.)

Under-burned, *salmon brick* is not acceptable under any building code for use in areas exposed to weather. Some codes, however, do permit unburned clay products such as *adobe brick*. Unless they are protected by a surface coating such as plaster, however, these sun-dried bricks are susceptible to severe moisture damage or disintegration. Commercially available adobe brick treated with emulsified asphalt has been tested and approved for use by some local authorities. Traditional blends of clay with straw or fiber reinforcing that have not been treated or certified must either be used in a completely sheltered location or receive a protective plaster or stucco coating.

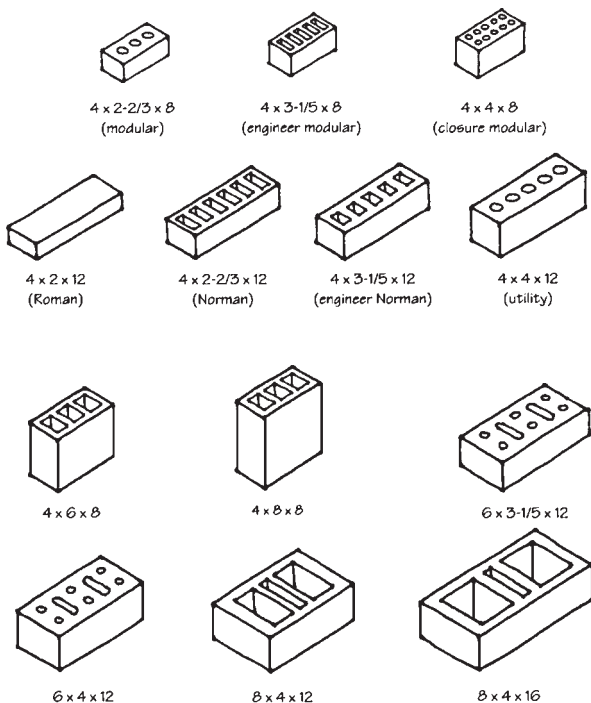
Over-burned *clinker brick* was more common when coal-fired periodic kilns were used. The units currently produced are made for special aesthetic effects, and should not be used in structural masonry or severe weathering exposures unless the masonry assemblage is tested for flexural strength and water permeance.

3.1.1 Sizes and Shapes

Masonry unit sizes and shapes have proliferated over the last 5000 years to meet various regional standards and design requirements throughout the world. Even within the United States, unit dimensions may vary from one area to the next and be further confused by different names for the same size of unit. At one time, there were only three commonly used brick sizes: "standard," Norman, and Roman. Industry demand has increased that number substantially. Brick is now available in widths or bed depths ranging from 3 to 12 in., heights from 2 to 8 in., and lengths of up to 16 in. Production includes both non-modular and modular sizes conforming to the 4-in. grid system of structural and material coordination. Some typical units are illustrated in *Figs. 3-5 and 3-6*, which list several of the modular sizes, their recommended joint thicknesses, and coursing heights.

For clarity in specifying brick, units should be identified first by dimensions, then by name, and actual dimensions should be used, listed width \times height \times length. Nominal dimensions may vary from actual sizes by the thickness of mortar joint with which the unit was designed to be used. Firebrick, however, is laid without true mortar beds, and sizes given should always be actual dimensions. Mortar joint thicknesses are determined by the type and quality of the unit. In general, glazed brick is laid with a $\frac{1}{8}$ -in. joint, face brick with a $\frac{3}{8}$ - or $\frac{1}{2}$ -in. joint, and building brick with a $\frac{1}{2}$ -in. joint.

The bricks in *Fig. 3-5* show a variety of core designs. Although they are typical of commercially available products, the corings vary with the manufacturer, and are not necessarily typical for or limited to the particular size with which they are shown. These design modifications have been developed over the years to facilitate, among other things, ease of forming, ease of handling, and improved grip and mortar bond. The oldest pattern is an indentation or "frog" producible only by dry-press or soft-mud processes. Originally conceived as a scheme for reducing the weight of a solid unit, this depression provided a space for identification by early craftsmen, who would write the name of the reigning monarch during the time of construction. This practice has since aided archaeologists in dating ancient buildings. Still in use today, the frog is now often stamped with the name of the brick manufacturer or date of production. Extruded brick is with a series of holes cored through the unit which, for "solid brick" as defined by ASTM, may not exceed 25% of the area in the bearing plane (see *Fig. 3-7*). In addition to the cores, a $\frac{3}{4} \times \frac{1}{2}$ -in. notch may be cut in one end of 6-in. brick to serve as a jamb unit. Roman brick is made in double form and broken into two units on the job site, leaving a rough, exposed edge.



Dimensions shown are nominal. Manufacturer's specified dimensions are usually 3/8" less than the nominal dimension.

Figure 3-5 Examples of modular brick sizes.

The trend in development of different brick sizes has been toward modular coordination and toward slightly larger dimensions. Most contemporary masonry products, including clay tile and concrete block, are designed for connection at 8- or 16-in. course heights. For example, two courses of concrete block with mortar joints will equal 16 in. vertically, while three, five, or six courses of various size brick and two, three, or four courses of clay tile equal the same height. This permits horizontal mechanical connection between the facing and backup elements of a multi-wythe wall. "Standard" brick produced

Modular Brick Sizes and Coursing								
Unit Designation	Nominal Dimensions (in.)			Joint Thickness (in.)	Specified Dimensions (in.)			Vertical Coursing
	W	H	L		W	H	L	
Modular	4	2-2/3	8	3/8 1/2	3-5/8 3-1/2	2-1/4 2-1/4	7-5/8 7-1/2	3 courses = 8 in.
Engineer modular	4	3-1/5	8	3/8 1/2	3-5/8 3-1/2	2-3/4 2-13/16	7-5/8 7-1/2	5 courses = 16 in.
Closure modular	4	4	8	3/8 1/2	3-5/8 3-1/2	3-5/8 3-1/2	11-5/8 11-1/2	1 course = 4 in.
Roman	4	2	12	3/8 1/2	3-5/8 3-1/2	1-5/8 1-1/2	11-5/8 11-1/2	2 courses = 4 in.
Norman	4	2-2/3	12	3/8 1/2	3-5/8 3-1/2	2-1/4 2-1/4	11-5/8 11-1/2	3 courses = 8 in.
Engineer Norman	4	3-1/4	12	3/8 1/2	3-5/8 3-1/2	2-3/4 2-13/16	11-5/8 11-1/2	5 courses = 16 in.
Utility	4	4	12	3/8 1/2	3-5/8 3-1/2	3-5/8 3-1/2	11-5/8 11-1/2	1 course = 4 in.
	4	6	8	3/8 1/2	3-5/8 3-1/2	5-5/8 5-1/2	7-5/8 7-1/2	2 courses = 12 in.
	4	8	8	3/8 1/2	3-5/8 3-1/2	7-5/8 7-1/2	7-5/8 7-1/2	1 course = 8 in.
	6	3-1/5	12	3/8 1/2	5-5/8 5-1/2	2-3/4 2-13/16	11-5/8 11-1/2	5 courses = 16 in.
	6	4	12	3/8 1/2	5-5/8 5-1/2	3-5/8 3-1/2	11-5/8 11-1/2	1 course = 4 in.
	8	4	12	3/8 1/2	7-5/8 7-1/2	3-5/8 3-1/2	11-5/8 11-1/2	1 course = 4 in.
	8	4	16	3/8 1/2	7-5/8 7-1/2	3-5/8 3-1/2	15-5/8 15-1/2	1 course = 4 in.

Figure 3-6 Modular brick size and coursing table.

before 1946–1947, when modular coordination was adopted, had actual heights of 2 $\frac{3}{4}$ in. (designed to lay up three courses to 8 in.). This size is still widely available so that in renovation or restoration work, coursing heights can be effectively matched.

One of the first oversize brick units was introduced by the Brick Industry Association (BIA). The SCR brick was developed for use in singlewythe, 6-in. loadbearing walls. Larger brick sizes have also increased labor production. Although a mason can lay fewer of the large units in a day, the square footage of wall area completed is greater, less mortar is required, and projects are completed faster.

In addition to the common rectangular cut, brick may be formed in many special shapes for specific job requirements. Some of the more commonly used items include square and hexagonal pavers, bullnose and stair tread units, caps, sills, special corner brick, and wedges for arch construction (see Fig. 3-8). Unique custom shapes may be available on request from some manufacturers, but can be expensive to produce depending on the size of the order. The color of special-shape bricks may not exactly match the standard-shape units in a

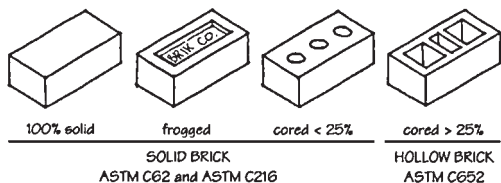
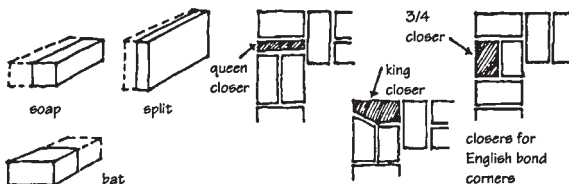


Figure 3-7 Solid brick and hollow brick.

JOB-CUT SHAPES



SPECIAL MANUFACTURED SHAPES

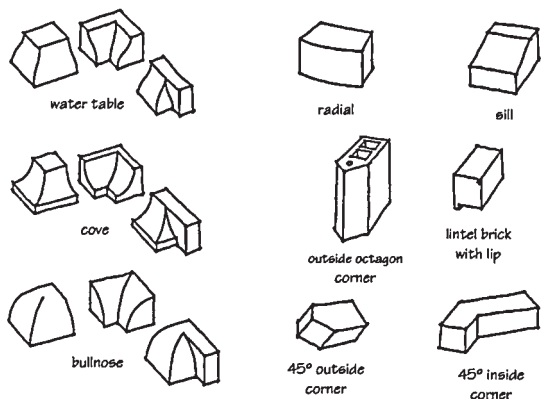


Figure 3-8 Job-cut and special manufactured brick shapes.

project because they are typically fired in a different run. The variations are usually minor but can be particularly noticeable at building corners and other vertical elements, where lighter and darker colors create a “zipper” look. Horizontal courses of special units blend into a wall better or, at worst, create a banding effect. Job-cut shapes must often be made for corners or other locations where a full brick length may not fit. These job-cut units are called half or bat, three-quarter closure, quarter closure, queen closure, king closure, and split.

The most unusual examples of customized masonry are sculptured pieces handcrafted from the green clayware before firing. The unburned units are firm enough to allow the artist to work freely without damage to the brick body, but sufficiently soft for carving, scraping, and cutting. After execution of the design, the units are returned to the plant for firing and the relief is permanently set in the brick face (see Fig. 3-9).

3.1.2 Hollow Brick

One of the traditional distinctions made between different clay masonry products is based on the definition of brick as “solid” (core area of less than 25%) and clay tile as “hollow” (more than 25% cored area). However, during the 1970s, new standards were developed for “hollow brick” with a greater core area than that previously permitted for brick, but less than that allowed for tile.



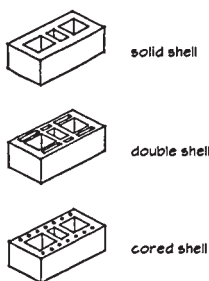
Figure 3-9 Sculptured brick is carved by the artist before the brick is fired. (Photo courtesy BIA.)

The trend toward larger unit sizes led to production of jumbo brick in $8 \times 4 \times 12$ -in. dimensions as early as the 1920s. In the southeastern United States, this prompted experimentation with greater coring as an effective means of reducing the weight and production costs of such large units. Originally made and marketed under a number of different proprietary names and specifications, these hollow bricks are now classified in ASTM C652, *Standard Specification for Hollow Brick* (see Fig. 3-10). Sometimes referred to as through-the-wall units, hollow bricks may be laid with opposite faces exposed. They offer considerable economy in speed and construction of masonry walls while maintaining the aesthetic appeal of conventional multi-wythe systems.

ASTM C652 covers hollow brick with core areas between 25 and 40% (Class H40V) and between 40 and 60% (Class H60V) of the gross cross-sectional area in the bearing plane. The two grades listed correspond to the same measure of durability as that used for building brick and face brick: Grade SW (severe weathering) and Grade MW (moderate weathering). Types HBX (Select), HBS (Standard), and HBA (Architectural) are identical to face brick Types FBX, FBS, and FBA. Another type, HBB, is for general use in walls and partitions where color and texture are not a consideration and greater variation in size is permissible (as for building brick or common brick). Hollow brick is used for both interior and exterior construction in much the same way as solid brick. Sizes range from $4 \times 2\frac{1}{4} \times 12$ in. to $8 \times 4 \times 16$ in.

3.1.3 Special-Purpose Bricks

Special-purpose bricks serve many functions in architecture and industry. Refractory bricks or *fire bricks*, for instance, are used in furnaces, chimney stacks, fireboxes, and ovens. The fire clay from which they are made has a much higher fusing point than that of ordinary clay or shale. Once the initial kiln firing has been accomplished, fire bricks are extremely resistant to high temperatures without cracking, decomposition, or distortion. Fire bricks are normally heavier and softer than other units and are produced in a slightly



- Class H40V—Hollow brick with voids 25 to 40%
- Class H60V—Hollow brick with voids 40 to 60%

Class H60V Hollow Brick Minimum Thickness of Face Shells and Webs (in.)			
Nominal Width of Units	Face Shell Thickness		End Shells or End Webs
	Solid	Cored or Double Shell	
3 and 4	3/4	—	3/4
6	1	1-1/2	1
8	1-1/4	1-1/2	1
10	1-3/8	1-5/8	1-1/8
12	1-1/2	2	1-1/8

Figure 3-10 ASTM C652 hollow brick coring and shell variations. (Copyright ASTM, 100 Barr Harbor Drive, West Conshohocken, PA 19428. Reprinted with permission.)

larger size ($4\frac{1}{2} \times 2\frac{1}{2} \times 9$ in.), to be laid with a thin coating of refractory mortar in lieu of standard mortar joints. Fire clays typically burn to a white or buff color, so fire bricks are usually in this color range as well.

Glazed bricks are fired with ceramic coatings which fuse to the clay body in the kiln and produce an impervious surface in clear or color, matte or gloss finish. Most colors are fired at temperatures around 2100°F. The glaze, which is about the same consistency as thick house paint, is sprayed on the raw clay unit, and both are fired together. These are called single-fired glazed bricks and are covered by ASTM C1405, *Standard Specification for Glazed Brick (Single Fired, Solid Brick Units)*. Requirements include unit strength and durability as well as properties of the glaze itself. Units are defined as Grade S (select) and Grade SS (select-sized, or ground edge), where a high degree of mechanical perfection, narrow color range, and minimum variation in size are required. Units may be either Type I, single-faced, or Type II, double-faced (opposite faces glazed). Type II units are generally special-order items and are not widely used. For weathering, units are designated as Exterior Class or Interior Class (see Fig. 3-11).

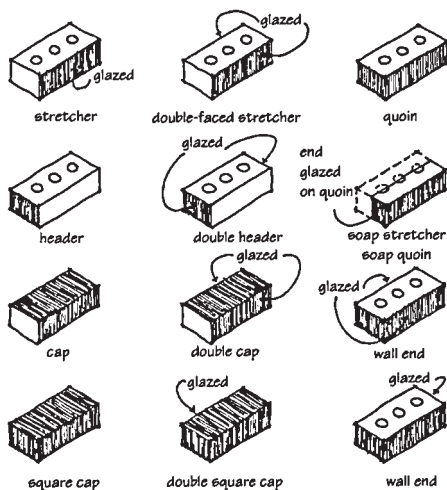
Some color glazes such as bright reds, primary yellows, burgundies, and oranges must be fired at lower temperatures, ranging from 1300 to 1800°F. A red glaze burns clear if it gets too hot because the cadmium and lead ingredients are not stable at high temperatures. This requires two firings. First the brick is fired at normal kiln temperatures, then the glaze is applied and the units are fired again at a low temperature. This two-fire process greatly increases the cost of the brick, and usually limits such colors to accents and specialty applications. Some low-fired glazes are prone to crazing because they are not as hard as high-fired glazes. Standards for *double-fired* glazed brick are outlined in ASTM C126, *Standard Specification for Ceramic Glazed Structural Clay Facing Tile, Facing Brick, and Solid Masonry Units*. Requirements cover compressive strength, imperviousness, chemical resistance, crazing, and limitations on distortion and dimensional variation. Durability and weather resistance are not covered, so for exterior use, the body of the brick should be specified to conform to the requirements for ASTM C216 face brick, Grade SW, Type FBX, with the glaze in accordance with ASTM C126 standards. Glazed brick may suffer severe freeze-thaw damage in cold climates if not adequately protected from moisture permeance, and is not recommended for copings or other horizontal surfaces in any climate. Units are manufactured in Grade S (select) and Grade SS (select sized, or ground edge), where a high degree of mechanical perfection, narrow color range, and minimum variation in size are required. Units may be either

ASTM C1405 Physical Requirements					
Class	Minimum Compressive Strength, Gross Area (psi)		Maximum Water Absorption by 24 hr. Cold, %	Maximum Saturation Coefficient	
	Average of 5 Brick	Individual Brick		Average of 5 Brick	Individual Brick
Exterior	6000	5000	7.0	0.78	0.80
Interior	3000	2500	—	—	—

Figure 3-11 ASTM C1405 glazed brick. (Copyright ASTM, 100 Barr Harbor Drive, West Conshohocken, PA 19428. Reprinted with permission.)

Type I, single-faced, or Type II, double-faced (opposite faces glazed). Type II units are generally special-order items and are not widely used. Glazed brick is commonly available in several sizes, and in stretchers, jambs, corners, sills, and other supplementary shapes (see Fig. 3-12).

The naturally high abrasion resistance of ceramic clay products makes them very durable as paving materials. *Paving brick* is unique in color, pattern, and texture and is often specified as a wearing surface for roadways, walks, patios, drives, and interior floors. ASTM C902, *Standard Specification for Pedestrian and Light Traffic Paving Brick*, lists specific physical requirements. Three traffic uses



- **Type I** Single-faced units for general use where only one finished face will be exposed.
- **Type II** Two-faced units for general use where two opposite finished faces will be exposed.
- **Grade S** Select—For use with comparatively narrow mortar joints.
- **Grade SS** Select Sized or Ground Edge—For use where variation of face dimension must be very small.
- **Class** Exterior
- **Class** Interior

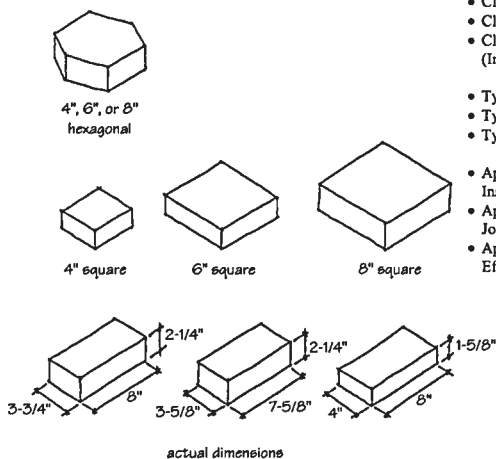
Figure 3-12 Glazed brick types, grades, and classes.

are covered: Type I, heavy traffic; Type II, intermediate traffic; and Type III, low traffic (see Fig. 3-13). Three weathering classifications, SX, MX and NX correspond to similar exposure limitations for face brick of severe, moderate, and negligible weathering. For extruded brick, Class SX requires a minimum average compressive strength of 8000 psi, a maximum average cold water absorption of 8%, and a maximum saturation coefficient of 0.78. Compressive strength and cold water absorption for Class SX molded brick are one-half that of extruded brick at 4000 psi and 16%, respectively. Maximum saturation coefficient is the same at 0.78. Size tolerances for paving brick are governed by the intended method of installation: application PS for setting with mortar joints or in running bond or other patterns not requiring extremely close dimensional tolerances; application PX for setting without mortar joints; and application PA, characteristically non-uniform to simulate the appearance of hand-made brick.

ASTM C1272, *Standard Specification for Heavy Vehicular Paving Brick*, covers units intended for service in heavy-use areas such as streets, commercial driveways, and aircraft taxiways. Two types of brick are covered (see Fig. 3-14). Type R (Rigid paving) is intended to be set in a mortar setting bed supported by an adequate concrete base or on an asphalt setting bed supported by an asphalt or concrete base. Type F (Flexible paving) is intended to be set in a sand setting bed with sand joints and may be installed on a flexible or rigid base. Three different applications are also covered, corresponding roughly to face brick appearance types. Application PS pavers are intended for general use. Application PX pavers are intended for use where dimensional tolerances, warpage, and chippage are limited. Application PA pavers are intended to produce characteristic architectural effects resulting from nonuniformity in size, color, and texture. Type R pavers must have a minimum average compressive strength of 8000 psi, a minimum modulus of rupture of 1200 psi, a maximum cold water absorption of 6%, and a minimum thickness of 2½ in. Type F pavers must have a minimum average compressive strength of 10,000 psi, a minimum modulus of rupture of 1500 psi, a maximum cold water absorption of 6%, and a minimum thickness of 2½ in.

Appearance depends largely on color, size, texture, and bond pattern. Paving brick is usually uncored and designed to be laid flat. Colors may range from reds to buffs, grays, and browns. Surface textures include smooth, velour, and rough, slip-resistant finishes. Standard or round-edge pavers are available in rectangular as well as square and hexagonal shapes.

Firebox brick is used as the lining in the fireboxes of residential fireplaces, and must have resistance to very high temperatures for extended periods of time. Firebox brick is often made from fire clay, which has a higher softening point than surface clay and shale. The low oxide content, which raises the softening point, also causes the brick to burn to a very light brown or light buff color approaching white. Firebox brick is typically installed with a mortar made from ground fire clay. Mortar joints are typically only ¼ in., or just thick enough to accommodate dimensional variations in the units. Tolerances on dimensional variations are important because tight fit is required to prevent heat loss through the back or sides of the firebox, which could result in both thermal inefficiency and fire hazard. ASTM C1261, *Standard Specification for Firebox Brick for Residential Fireplaces*, covers material requirements, physical properties, and fabrication tolerances. Units must be 100% solid, with no cores or frogs, must have a minimum modulus of rupture of 500 psi, and a pyrometric cone equivalent of 13. Since firebox brick is designed to be laid with very thin refractory mortar joints, the size tolerances permitted by ASTM C1261 are very restrictive (see Fig. 3-15).



- Class SX—Severe Weathering
- Class MX—Moderate Weathering
- Class NX—No Weathering (Interior Use Only)
- Type I—Heavy Traffic
- Type II—Intermediate Traffic
- Type III—Low Traffic
- Application PS—Standard Mortar Installation
- Application PX—Precision Dry Joint Installation
- Application PA—Architectural Effects

Physical Requirements						
Unit	Minimum Compressive Strength, Flatwise, Gross Area (psi)		Maximum Cold Water Absorption (%)		Maximum Saturation Coefficient	
	Average of 5 Bricks	Individual	Average of 5 Bricks	Individual	Average of 5 Bricks	Individual
Class SX	8000	7000	8	11	0.78	0.80
Class MX	3000	2500	14	17	no limit	no limit
Class NX	3000	2500	no limit	no limit	no limit	no limit

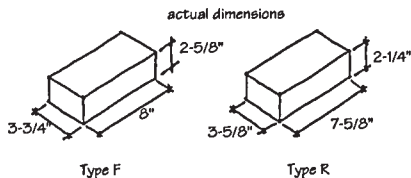
Abrasion Requirements		
Unit	Maximum Abrasion Index	Volume Abrasion Loss, (Max. cm ³ /cm ²)
Type I	0.11	1.7
Type II	0.25	2.7
Type III	0.50	4.0

Maximum Permissible Extent of Chippage		
Application	Chippage (in.) in From	
	Edge	Corner
PS	5/16	1/2
PX	1/4	3/8
PA	as specified by purchaser	

Figure 3-13 Requirements for pedestrian and light traffic paving brick. (Tables on this page copyright ASTM, 100 Barr Harbor Drive, West Conshohocken, PA 19428. Reprinted with permission.)

- Type R—brick intended to be set in a mortar setting bed supported by an adequate concrete base, or an asphalt setting bed supported by an adequate asphalt or concrete base
- Type F—brick intended to be set in a sand setting bed, with sand joints, and supported by an adequate base
- Application PS—pavers intended for general use
- Application PX—pavers intended for use where dimensional tolerances, warpage, and chippage are limited
- Application PA—pavers intended to produce characteristic architectural effects resulting from non-uniformity in size, color, and texture

Abrasion Requirements		
Type	Maximum Abrasion Index	Volume Abrasion Loss, (Max. cm ³ /cm ²)
R	0.11	1.7
F	0.11	1.7



Tolerances on Dimensions			
Dimension (in.)	Maximum Permissible Variation (\pm in.)		
	Application PS	Application PX	Application PA
3 and under	1/8	1/16	no limit
Over 3 to 5	3/16	3/32	no limit
Over 5 to 8	1/4	1/8	no limit
Over 8	5/16	7/32	no limit

Maximum Permissible Extent of Chippage		
Application	Chippage (in.) in from	
	Edge	Corner
PS and PX	5/16	1/2
PA	no limit	no limit

Tolerances on Distortion			
Specified Dimension (in.)	Maximum Permissible Distortion (in.)		
	Application PS	Application PX	Application PA
8 and under	3/32	1/16	no limit
Over 8 to 12	1/8	3/32	no limit
Over 12	5/32	1/8	no limit

Physical Requirements						
Type	Minimum Compressive Strength, Gross Area (psi)		Maximum Cold Water Absorption (%)		Minimum Modulus of Rupture (psi)	
	Average of 5 Bricks	Individual	Average of 5 Bricks	Individual	Average of 5 Bricks	Individual
R	8000	7000	6.0	7.0	1200	1000
F	10000	8800	6.0	7.0	1500	1275

Figure 3-14 Requirements for heavy vehicular paving brick. (Tables on this page copyright ASTM, 100 Barr Harbor Drive, West Conshohocken, PA 19428. Reprinted with permission.)

Physical Requirements		
	Minimum Modulus of Rupture (psi)	Minimum Pyrometric Cone Equivalent (PCE)
Firebox brick	500	13

Tolerances on Dimensions		
Specified Dimension (in.)	Maximum Permissible Variation in Dimension (\pm in.)	Maximum Permissible Distortion (in.)
3 and under	1/16	1/32
Over 3 to 4	1/16	3/64
Over 4 to 6	3/32	1/16
Over 6 to 8	1/8	5/64
Over 8 to 12	5/32	1/8

Figure 3-15 ASTM C1261 firebox brick. (Copyright ASTM, 100 Barr Harbor Drive, West Conshohocken, PA 19428. Reprinted with permission.)

Refractory brick of different chemical composition is covered in a series of ASTM standards, and is graded according to fusion temperature, porosity, spalling strength, resistance to rapid temperature changes, thermal conductivity, and heat capacity. Some commonly used types of refractory brick are alumina brick, chrome brick, magnesite brick, and silica brick. The highly specialized nature of refractory design requires consultation with manufacturers to assure correlation between design needs and product specifications.

Many industrial operations, such as foundries, steel mills, refineries, and breweries, require flooring materials that are resistant to vibration, impact, heavy vehicular traffic, thermal shock, and chemical attack. *Industrial floor brick* has been used successfully in these applications because of its dense structure, chemical stability, hardness, and “non-dusting” characteristics. Four basic types of units are described in ASTM C410, *Standard Specification for Industrial Floor Brick*, and are classified on the basis of absorption, chemical resistance, and modulus of rupture. Type T provides high resistance to thermal shock and mechanical impact, but also has relatively high absorption (10%). Type H has a lower percentage of absorption (6%), but offers only moderate resistance to chemicals and thermal shock. Type M should be used where low absorption (2%), limited mechanical shock resistance, and high resistance to abrasion are required. Type L provides minimum absorption (1%) and maximum chemical and abrasion resistance, but limited resistance to thermal and mechanical shock. Jointing material for industrial floor brick should be portland cement mortar or grout or, when required, chemical-resistant mortar.

Most well-burned clay masonry, including conventional face brick, building brick, structural clay tile, and ceramic glazed units, has excellent resistance to chemicals and chemical agents. In some installations, however, such as waste treatment facilities, dairies, chemical plants, refineries, and food processing plants, extraordinary resistance may be required. *Chemical-resistant bricks* or acid-proof bricks are machine-made, uncured, kiln-fired units made specifically for this purpose. They are strong, free of laminations,

burned to vitrification to close all pores, and sufficiently rough in texture to ensure complete and intimate bond with the mortar. Conditions of temperature and acidity and the absorption rate of the unit are the primary factors governing material selection for use in corrosive environments. Determination of the nature and severity of exposure will dictate which of the three types of units covered in ASTM C279, *Standard Specification for Chemical-Resistant Masonry Units*, should be used. Type I has low absorption (6%) and high sulfuric acid resistance. Type II has lower absorption (4%) and higher acid resistance. Type III has minimum absorption (1%) and maximum acid resistance. The three types do not differ significantly in thermal shock resistance. Chemical-resistant brick performs satisfactorily in the presence of mild alkalis and all acids except hydrofluoric. In instances where strong alkalis or hydrofluoric acid and its salts are present, a special "carbon brick" is required. Chemical-resistant mortars must be used with these units to assure effective performance (see Chapter 6).

ASTM C32, *Standard Specification for Sewer and Manhole Brick*, identifies two grades for each usage. For *sewer brick*, Grades SS and SM distinguish between the amounts and velocities of abrasive materials carried. Grade SS is lower in absorption and offers greater erosion resistance. *Manhole brick* is graded on its ability to withstand freezing action rather than abrasion. Grade MS provides a high and uniform degree of resistance, while Grade MM offers only moderate and nonuniform resistance. These bricks may be used in drainage structures for the conveyance of sewage, industrial wastes, and storm water, and for related structures such as manholes and catch basins.

3.1.4 Glass Block

Glass block can be used as security glazing, or to produce special daylighting effects. Glass block is considered a masonry material since it is laid up in cement mortar and uses the same type of joint reinforcement as other units. Although they are not made from clay, glass blocks do share some common characteristics with burned clay products. Both contain silicates as a primary raw ingredient, and the glass units, like brick, undergo vitrification when subjected to a heat process. They are available in a variety of sizes, and in both solid and hollow form (see Fig. 3-16). Decorative blocks are produced in clear, reflective, or color glass with smooth, molded, fluted, etched, or rippled texture. Functionally, glass block is used to diffuse or direct light for different illuminating requirements and provide a high level of security and energy efficiency for glazed areas. Compressive strengths range from 400 to 800 psi.

Most glass block is made of clear, colorless glass that admits the full spectrum of natural light (see Fig. 3-17). Hollow block with patterns pressed into the interior face partly or totally distorts images, creating visual privacy. Units made with glass fiber inserts reduce glare and brightness. Other units diffuse or reflect light. Glass blocks can increase or reduce solar heat gain, and because of their large air cavity, hollow blocks have greater thermal resistance than ordinary flat glass (see Fig. 3-17). A partial vacuum created when the hollow units are made further improves their thermal resistance.

Solar reflective block is coated with a heat-bonded oxide which can reduce solar heat gain by as much as 80% compared with conventional $\frac{1}{2}$ -in. flat glass (see Fig. 3-18). Glass fiber inserts further reduce solar heat gain by about 5%, and also increase thermal resistance.

Glass block comes in nominal face sizes of 6×6 -, 8×8 -, and 12×12 -in. square units and 4×8 - and 6×8 -in. rectangular units. Actual dimensions

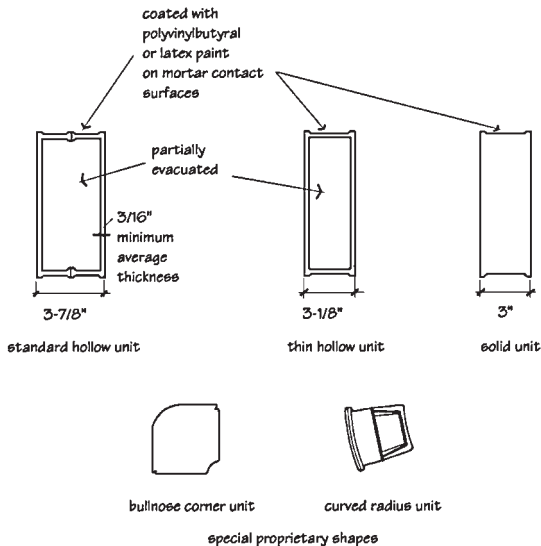


Figure 3-16 Glass block sizes and shapes.

vary by manufacturer and style. Units made in the United States are $\frac{1}{8}$ -in. less than nominal dimensions. Most hollow blocks are $\frac{3}{16}$ in. thick (nominal 4 in.), but some manufacturers also make thin blocks which measure only $\frac{3}{16}$ in. and weigh 20% less than standard units. Solid glass blocks are used for high-security glazing. They come in 3×8 -in. rectangular units and 8×8 -in. square units. Ordinary construction methods require limiting the number of courses laid at one time so that fresh mortar is not extruded from the joints by the weight of the block. There are several proprietary types of spacers that help speed construction. Unit weight is transferred directly from block to block by the spacers, allowing work to progress rapidly without waiting for substantial mortar cure to support the weight of the units. Mortar adhesion to glass block is limited.

3.2 STRUCTURAL CLAY TILE Structural clay tile is the most recently developed of clay masonry products, first produced in this country in 1875. Up until that time, most buildings were constructed with solid loadbearing masonry walls. With the invention and mastery of cast iron and steel structural framing, a need arose for lightweight backing materials for the facing masonry used to clad these

Unit Type	Light Transmitted (%)	U-Value	Shading Coefficient	Heat Gain (Btu/hr/sq.ft)
Solid	80	—	—	—
Hollow	50-75	—	—	—
Diffusion	28-40	—	—	—
Reflective	5-20	—	—	—
8 x 8 reflective	20	0.51	0.25	42
8 x 8 clear	62	0.51	0.65	140
1/4" clear sheet glass	90	1.04	1.00	215

Figure 3-17 Light transmission and thermal performance characteristics of glass block.



Figure 3-18 Glessel School of Art, Houston. Morris/Aubry architects. (Photo courtesy Houston Museum of Fine Arts.)

skeleton frames. Clay tile satisfied the demand and added elements of economy and fire resistance.

Structural clay tile is still produced by a limited number of manufacturers, both for new construction and for restoration/retrofit work. It is used as structural, facing, and backup material in construction. Tile, like brick, is made of clay that is molded and then fired in a kiln to ceramic fusion. Clay tile may be used with the hollow cells either horizontal or vertical (side construction or end construction tile), for both loadbearing and non-loadbearing applications. “Structural” clay tile is distinguished from flat clay wall tile and flat clay floor tile by its ability to carry load and support its own weight. The numerous types of tile used today are classified by function. *Structural clay loadbearing wall tile* and *structural clay non-loadbearing tile* may be used in the construction of walls and partitions where a finish coat of plaster or other material will be applied or where appearance is not a primary concern. These

units are the equivalent of building brick, and are considered principally utilitarian in nature. *Structural clay facing tile* and *ceramic glazed facing tile* may be loadbearing or non-loadbearing, but are distinguished from the above on the basis of finish, much the same as face brick is distinguished from building brick.

3.2.1 Loadbearing Wall Tile

ASTM C34, *Standard Specification for Structural Clay Loadbearing Wall Tile*, divides units into two grades based on compressive strength and resistance to frost action in the presence of moisture (see Fig. 3-19). The higher grade, LBX, is suitable for areas exposed to weathering provided it meets the same durability requirements as Grade SW, ASTM C216 face brick. Grade LB is limited to unexposed areas unless protected by at least 3 in. of stone, brick, terra cotta or other masonry. In either case, the tile carries the structural load, the live load, and the weight of the facing material, plus its own weight. Loadbearing tile may also be used in composite wall construction with facing tile, brick, or other masonry units. In this instance, the wythes of the wall are bonded together structurally so that the tile bears an equal share of the superimposed load.

3.2.2 Non-Loadbearing Tile

ASTM C56, *Standard Specification for Structural Clay Non-Loadbearing Tile*, covers partition tile, furring tile, and fireproofing tile. The standard includes

Type and Grade	Maximum Water Absorption by 1-Hour Boiling (%)		Minimum Compressive Strength [†] (psi)			
			End Construction Tile		Side Construction Tile	
	Average of Five Units	Individual Unit	Minimum, Average of Five Tests	Minimum, Individual	Minimum, Average of Five Tests	Minimum, Individual
Loadbearing Tile (ASTM C34)						
Grade LBX	16	19	1400	1000	700	500
Grade LB	25	28	1000	700	700	500
Non-Loadbearing Tile (ASTM C56)						
Grade NB	—	28	—	—	—	—
Facing Tile (ASTM C212)						
Type FTX	9	11	—	—	—	—
Type FTS	16	19	—	—	—	—
Standard Class	—	—	1400	1000	700	500
Special Duty Class	—	—	2500	2000	1200	1000
Glazed Tile (ASTM C126)	—	—	3000	2500	2000	1500

[†] Based on gross area, obtained as a product of horizontal face dimension (as placed in the wall) times thickness.

Figure 3-19 Physical requirements for structural clay tile.

only one grade, NB, and one physical property specification, which limits the rate of water absorption to 28%. *Partition tile* is used to construct non-loadbearing interior partitions. *Furring tile* is used to line the inside surface of exterior walls, providing an insulating air space and a surface suitable for plastering. Partition and furring tile may be used to fireproof structural steel members, but for some applications around beams and girders, special shapes of *fireproofing tile* are required to conform to the profile of the steel. Clip and angle shapes have been devised for this purpose and, when used in conjunction with conventional rectangular tiles, provide a simple means of complete coverage (see Fig. 3-20).

Tile that will be plastered must have a surface texture that provides good bond between plaster and unit (see Fig. 3-21). ASTM C56 covers smooth (wire cut), scored, combed, and roughened finishes.

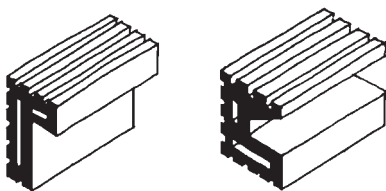


Figure 3-20 Clip and angle tiles for fireproofing steel beams.

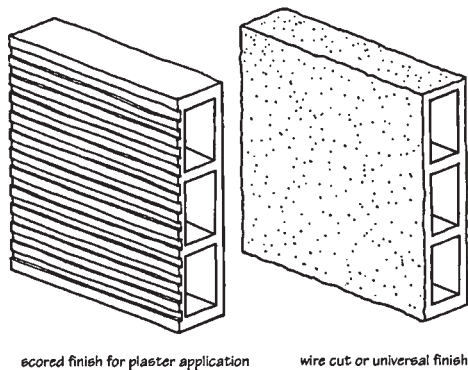


Figure 3-21 Tile is available with several different surface textures.

3.2.3 Facing Tile

Facing tile combines the loadbearing capacity of ordinary structural clay tile with a finished surface suited for architectural applications. These natural-color unglazed tiles are covered in ASTM C212, *Standard Specification for Structural Clay Facing Tile*. Two classes of tile are defined, based on face shell and web thickness. “Standard” tiles are general-purpose units for exterior or interior locations. “Special duty” tiles have heavier webs and shells designed to increase resistance to impact and moisture penetration. Aesthetic factors are designated the same as for face brick. Type FTX (Select) tiles have a smooth finish for general use in interior and exterior applications requiring minimum absorption, easy cleaning, and resistance to staining. They provide a high degree of mechanical perfection, narrow color range, and minimum variation in face dimensions. Type FTS (Standard) tiles may have a smooth or rough texture, are suitable for interior and exterior construction where moderate absorption and moderate variation in face dimensions are permissible, and may be used where minor defects in surface finish are not objectionable. ASTM C212 lists compressive strength and absorption, and sets limits on chippage, dimensional variation, and face distortion (see Fig. 3-19). Sizes and shapes are shown in Fig. 3-22.

3.2.4 Ceramic Glazed Facing Tile

Most of the structural clay tile used in new construction today is glazed. Glazed units are also of loadbearing quality, but have an impervious finish in either clear or color glaze. Physical requirements are outlined in ASTM C126, which also governs glazed brick. For exposed exterior applications, the tile body should also meet the durability requirements for ASTM C652, Grade SW hollow brick units. Exterior applications should also be limited to vertical cell tile, since horizontal cells can trap moisture in the wall. If the units are frozen when wet, the glazed surface can easily spall. Grade and type classifications for glazed tile are identical to those for glazed brick. Grade S (select) units are used with comparatively narrow mortar joints. Grade SS (selected sized, or ground edge) are used where variation of face dimension must be very small. Both grades may be produced in either Type I, single-faced units, where only one face is glazed, or Type II, double-faced, where two opposite faces are glazed. ASTM C126 covers compressive strength, absorption rate (see Fig. 3-19), number of cells, shell and web thickness, dimensional tolerances, and properties of the ceramic finish, including imperviousness, chemical resistance, and crazing.

The shapes of all structural tile units are controlled by the dies through which the plastic clay is extruded. The relative ease with which various designs can be produced led to the development of a large number of sizes and patterns. Through a process of standardization, this number has been reduced to only the most economical and useful units. Development and acceptance of the criteria for modular coordination encouraged refinement aimed at correlation with other manufactured masonry products. Structural clay tile is designed for use with $\frac{1}{4}$ -, $\frac{3}{8}$ -, or $\frac{1}{2}$ -in. mortar joints, while facing tile uses only $\frac{1}{4}$ -in. joints. Nominal dimensions, as for brick, include this thickness and are multiples of the 4-in. module or fractions of a multiple of that module (i.e., three courses of 5 $\frac{1}{2}$ -in.-high tiles equals 16 in.).

The nomenclature of shape numbers can be bewildering because of the many possible combinations, but the system is really fairly simple (see Fig. 3-23). The prefix is an alphanumeric designation of length, height, and coring, followed by numbers denoting horizontal and vertical axis conditions (such as cove base, bullnose, or stretcher) and bed depth, and a letter suffix

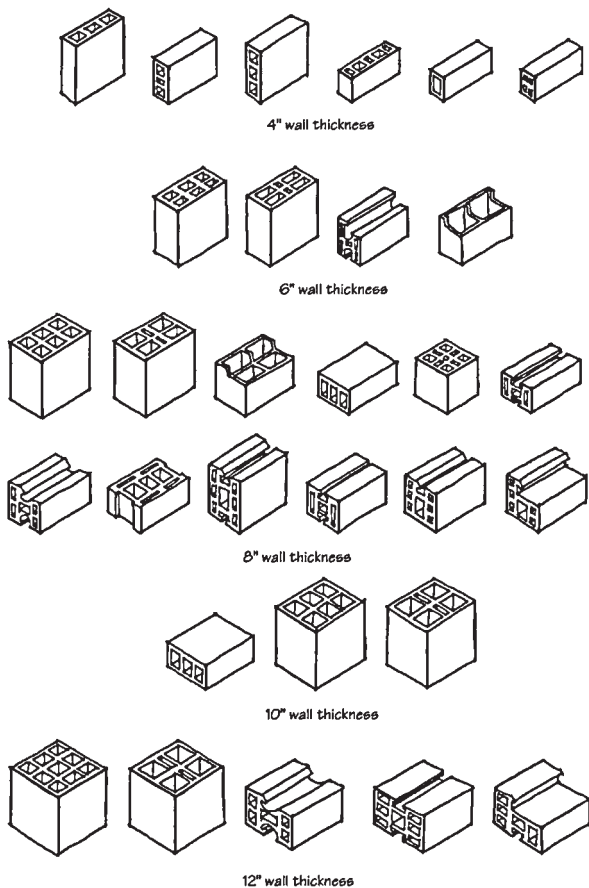
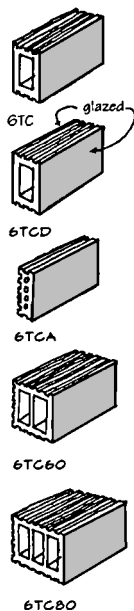


Figure 3-22 Some typical shapes and sizes available in structural clay loadbearing, non-loadbearing, and facing tile.

Available Sizes		
Series	Nominal Face Dimensions (in.)	Nominal Thickness (in.)
6T	5-1/3 X 12	2, 4, 6, 8
4D	5-1/3 X 8	2, 4, 6, 8
4S	2-2/3 X 8	2, 4
4W	8 X 8	2, 4, 6, 8
8W	8 X 16	2, 4, 6, 8

Nomenclature	
Prefix: denotes face size	6T, 8W, etc
Number: denotes horizontal or vertical axis and unit type	bullnose, stretcher, quoin, etc.
Suffix: denotes bed depth and return, reveal or back face, and right- or left hand shape	
Example:	6T24CR

STRETCHERS



SILLS, CAPS, CORNERS, JAMBS, COVE BASES

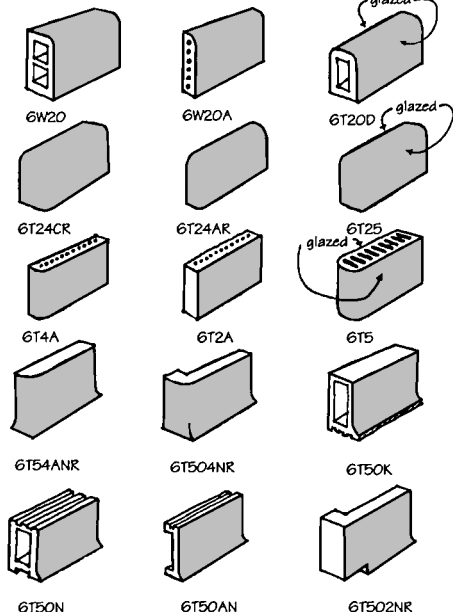


Figure 3-23 Glazed structural clay tile shapes.

denoting return and reveal, back surface finish, and right- or left-hand unit when required.

Because of the glazed surface, a larger variety of special shapes is required to facilitate door and window openings, headers, corners, and so on. In addition to full-size stretcher units, shapes include half-lengths, half-heights, and corner and jamb units, as well as sills, caps, lintels, cove bases, and coved internal corners (see Fig. 3-24). Some manufacturers prepare shop

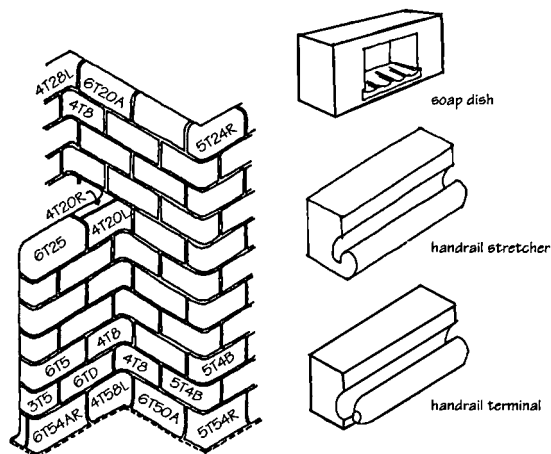
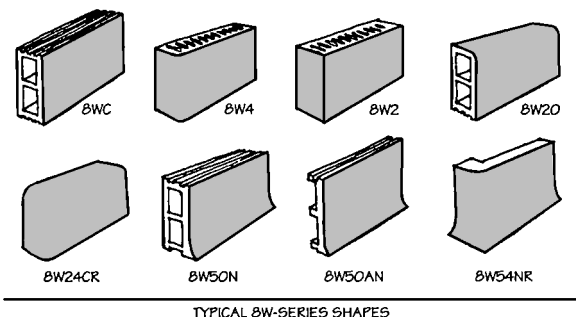


Figure 3-24 Glazed structural clay tile shapes and applications.

drawings from the architectural plans to show actual tile shapes and locations. If the project is laid out with modular dimensions, very few (if any) extraordinary special shapes will be required and job-site cutting and waste will be minimum.

Structural glazed tile has long had a place in commercial kitchens, bottling and food processing plants, schools, and hospitals because of its durable surface and low maintenance requirements. But more and more architects are turning to this material for use in correctional facilities and in high-traffic public buildings such as airports, shopping malls, and sporting arenas. Unlike glazed brick, glazed structural clay tile allows single-wythe construction of walls and partitions glazed on both sides.

Glazed tile is available in traditional pastels and in bold colors such as fire engine red and cobalt blue. It also comes with either smooth or textured surfaces. The 8 × 8-in. modular and 8 × 16-in. face sizes are most popular today because they course easily with other types of masonry. Scored 8 × 16-in. units are available that simulate the look of 8 × 8 stack bond. Like glazed brick, glazed structural tile is impervious to stains, resistant to fading and crazing, and unaffected by many chemicals including hydrochloric acid and caustic cleaning solutions. Its abrasion resistance is greater than that of ordinary steel when rated on the Mohs hardness scale. As long as the mortar is designed to resist the same abuse expected of the units, a structural glazed tile wall will last the life of the building with no maintenance other than washing. Even when concrete masonry is used for walls, a structural glazed tile cove base provides better resistance to the abuse of floor cleaning equipment and traffic than ordinary block.

For applications requiring extremely sanitary conditions, and for high-abuse areas, joints can be raked out and pointed with epoxy mortar. Walls can then be hosed down, scrubbed, or steam cleaned without damaging the mortar and without allowing moisture to enter the wall. After the joints are raked, the setting mortar should cure for 24 hours before pointing with the epoxy mortar.

3.2.5 Screen Tile

Clay masonry solar screens have always found wide acceptance whether constructed of screen tile or of standard units ordinarily used for other purposes. Screen tile is available in a variety of shapes and patterns (see Fig. 3-25). Lighter colors, because of greater reflectivity, provide brighter interiors. Darker colors absorb more of the sun's heat and light and give greater protection from its harsh rays.

Screen tile is covered by ASTM C530, *Standard Specification for Structural Clay Non-Loadbearing Screen Tile*. Grades SE, ME, and NE correspond to the severe weather, moderate weather, and no weather exposure durability ratings of other clay masonry products (see Fig. 3-26). Only two aesthetic types are included, though, Type STX (Select) and Type STA (Architectural).

3.3 TERRA COTTA

Architectural terra cotta has been used as a decorative veneer for centuries. The name itself, which means "baked earth," dates from Roman antiquity. Hand-molded slabs with either plain or sculptured surfaces are still produced in the traditional manner, and extruded units are mechanically fabricated with smooth-ground, beveled, scored, scratched, or fluted surfaces. Both the hand- and machine-made types may be glazed in clear, monochrome, or polychrome colors and in matte, satin, or gloss finishes.

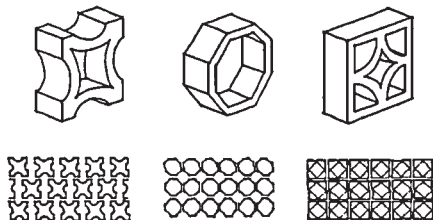


Figure 3-25 Typical clay screen tile shapes and patterns.

- **Grade SE**—uniformly high resistance to disintegration by weathering or by freezing or thawing in the presence of moisture
- **Grade ME**—moderate and somewhat non-uniform resistance to weathering (good durability in areas of mild to moderate exposure, but not adequate for severe exposures)
- **Grade NE**—interior use only
- **Type STX**—minimum size variation
- **Type STA**—characteristic architectural effects resulting from larger degree of size variation

Grade	Maximum Water Absorption by 1-Hour Boiling (%)	
	Average of 5 Tests	Individual Unit
SE	10	12
ME	14	16
NE	20	24

Specified Dimension (in.)	Maximum Permissible Variation from Specified Dimensions (\pm in.)	
	Type STX	Type STA
4 and under	3/32	1/8
Over 4 to 6	1/8	3/16
Over 6 to 8	5/32	1/4
Over 8 to 12	7/32	5/16
Over 12	9/32	3/8

Figure 3-26 Requirements for structural clay non-loadbearing screen tile. (Tables copyright ASTM, 100 Barr Harbor Drive, West Conshohocken, PA 19428. Reprinted with permission.)

Sometimes referred to as ceramic veneer, architectural terra cotta is an enriched clay mixture fired at high temperatures to a hardness and density not obtainable with brick. Glazed units are durable and weather resistant, and provide an almost infinite range of colors that will retain their sharpness and clarity for the life of the product.

Architectural terra cotta was originally used as a loadbearing element in multi-wythe walls, but in the late nineteenth and early twentieth centuries, it gained popularity as a cladding material, particularly for structural frame-type buildings. It was lightweight, relatively inexpensive, and particularly adaptable to rich ornamental detailing. Architectural terra cotta figured prominently in the work of H. H. Richardson, Cass Gilbert, Louis Sullivan, and Daniel Burnham, among others, and was a key element in such architectural

idioms as the Chicago School, the Gothic and Romanesque Revival movements and the Beaux Arts style. Though architectural terra cotta is one of the most prevalent materials from this period, many are unaware of its presence because it frequently masqueraded as stone. Building owners and architects alike are often surprised to discover that what they presumed to be a granite, limestone, or brownstone facade is actually glazed terra cotta.

Today, terra cotta is produced for both historic restoration and new construction. Flat field panels, the basic units of veneer systems, must have scored or dovetailed backs to form a key with the mortar. Accessory pieces such as copings, sills, and projecting courses are also die formed, and may be simple or elaborate in profile. *Figure 3-27* shows the stock shapes used to create the cornice and base courses on the Best Products Corporate Headquarters Building. The backs and webs of units, as shown, are often cut at the factory or broken out at the job site to accommodate mechanical fasteners. Decorative balusters and hand-molded ornamental shapes are also available. Reproduction pieces can be made by taking a plaster cast of existing features and then hand-packing wet clay into a mold made from the cast.

There are no ASTM standards for terra cotta, but units should meet the minimum requirements of the "Standard Specifications for Ceramic Veneer," and "Standard Methods for Sampling and Testing Ceramic Veneer" published by the Architectural Terra Cotta Institute (1961). Glazes, however, are covered by ASTM C126, *Standard Specifications for Ceramic Glazed Structural Clay Facing Tile, Facing Brick and Solid Masonry Units*.

3.4 PROPERTIES AND CHARACTERISTICS OF FIRED CLAY PRODUCTS

Physical properties and characteristics of masonry units are important to the architect only insofar as they affect performance and appearance of the finished wall or structure. The major building codes in the United States rely primarily on ASTM standards and requirements of the American National Standards Institute (ANSI) for minimum property specifications. These deal mainly with compressive strength, absorption, and saturation coefficients as indicators of acceptable performance (see *Fig. 3-28*).

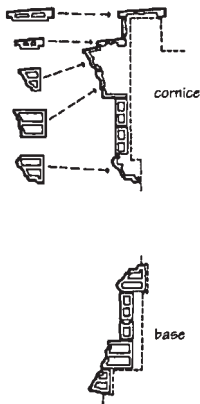


Figure 3-27 Stock shapes of extruded terra cotta used to form cornice and base courses at Best Products Corporate Headquarters.

Unit	Weathering Grade	Minimum Compressive Strength, Gross Area (psi)		Maximum Water Absorption by 5-Hour Boiling (%)		C/B Maximum Saturation Coefficient	
		Average of 5 Tests	Individual Unit	Average of 5 Tests	Individual Unit	Average of 5 Tests	Individual Unit
Face brick (ASTM C216)	SW	3000	2500	17	20	0.78	0.80
	MW	2500	2200	22	25	0.88	0.90
Building brick (ASTM C62)	SW	3000	2500	17	20	0.78	0.80
	MW	2500	2200	22	25	0.88	0.90
	NW	1500	1250	no limit	no limit	no limit	no limit
Hollow brick (ASTM C652)	SW	3000	2500	17	20	0.78	0.80
	MW	2500	2200	22	25	0.88	0.90
Glazed brick (ASTM C1405)	Exterior	6000	5000	—	7 (cold water)	0.78	0.80
	Interior	3000	2500	—	—	—	—
Glazed brick (ASTM C126)	—	3000	2500	—	—	—	—
	—	2000	1500	—	—	—	—

Grade Recommendations for Brick Exposures in Exterior Walls

Exposure	Weathering Index	
	Less Than 50	50 and Greater
In vertical surfaces:		
In contact with earth	MW	SW
Not in contact with earth	MW	SW
In other than vertical surfaces:		
In contact with earth	SW	SW
Not in contact with earth	MW	SW

Grade SW Brick intended for use where high and uniform resistance to damage caused by cyclic freezing is desired, and where the brick may be frozen when permeated with water.

Grade MW Brick which may be used where moderate resistance to cyclic freezing damage is permissible or where the brick may be damp but not permeated with water when freezing occurs.

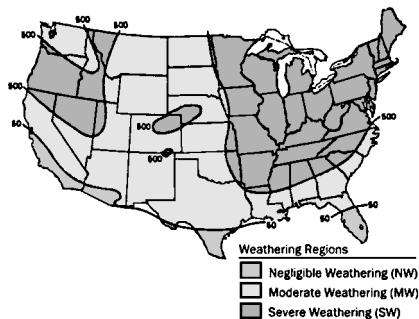


Figure 3-28 Minimum physical requirements for brick. (Copyright ASTM, 100 Barr Harbor Drive, West Conshohocken, PA 19428. Reprinted with permission.)

3.4.1 Compressive Strength

The compressive strengths of brick and tile are usually based on gross area. Extruded bricks generally have higher compressive strength and lower absorption than those produced by the soft-mud or dry-press processes. For a given clay and method of manufacture, higher compressive strength and lower absorption are also associated with higher burning temperatures. The minimum compressive strength values listed in *Fig. 3-28* are substantially exceeded by most manufacturers. Actual compressive strengths of clay masonry units are usually higher than those of ordinary structural concrete. For standard-run brick, strengths typically range from 1500 to 22,500 psi, with the majority of units produced being in excess of 4500 psi (see *Fig. 3-29*).

3.4.2 Transverse Strength

The transverse strength of a brick acting as a beam supported at both ends is called the *modulus of rupture*. Tests at the National Institute of Standards and Technology (NIST) indicate minimum values for well-burned brick to be in excess of 500 psi, with a maximum average of 2890 psi. There is no general

Brick Classification by Compressive Strength			Actual Compressive Strength of Brick Produced in the United States	
Designation	Minimum Compressive Strength (psi)		Range (psi)	Percentage of Production Within Range (%)
	Average of 5 Units	Individual Unit		
2,500	2,500	2,200	21,001 to 22,500	0.46
4,500	4,500	4,000	19,501 to 21,000	0.69
6,000	6,000	5,300	18,001 to 19,500	0.46
8,000	8,000	7,000	16,501 to 18,000	2.04
10,000	10,000	8,800	15,001 to 16,500	1.49
12,000	12,000	10,600	13,501 to 15,000	3.71
14,000	14,000	12,300	12,001 to 13,500	4.76
(From Schneider and Dickey, Reinforced Masonry Design).			10,501 to 12,000	7.78
			9,001 to 10,500	8.61
(from Brick Industry Association [BIA], Principles of Brick Masonry, 1973)			7,501 to 9,000	11.92
			6,001 to 7,500	15.47
			4,501 to 6,000	16.81
			3,001 to 4,500	17.97
			1,501 to 3,000	7.46
			0 to 1,500	0.36
			Total Percent	99.99

Figure 3-29 Compressive strength of brick.

rule, however, for converting values of compressive strength to transverse strength, or vice versa. Tensile and shearing properties of brick have not been widely tested, but data from NIST indicates that *tensile strength* normally falls between 30 and 40% of the modulus of rupture and *shear values* from 30 to 45% of the net compressive strength. Tensile strength of structural clay tile is quite low and usually will not exceed 10% of the compressive strength. The *modulus of elasticity* for brick ranges from 1,400,000 to 5,000,000.

3.4.3 Absorption

The weight of burned clay products ranges from 100 to 500 lb/cu ft. Variations may generally be attributed to the process used in manufacturing and burning. Increased density and weight result from fine grinding of raw materials, uniform mixing, pressure exerted on the clay as it is extruded, de-airing, and hard or complete burning. The extrusion process produces very dense brick and tile characterized by high strength and a small percentage of voids. Since properties of absorption are also affected by the method of manufacture and degree of burning, these factors indicate fairly close relationships among total absorption, weight, density, and compressive strengths. With few exceptions, hard-burned units are highest in strength and density and lowest in absorption.

The absorption of a brick or clay tile is defined as the weight of water taken up by the unit under given laboratory test conditions, and is expressed as a percentage of the dry weight of the unit. Since highly absorptive brick exposed to weathering can cause a build-up of damaging moisture in the wall, ASTM standards limit face brick absorption to 17% for Grade SW and 22% for Grade MW units. Most brick produced in the United States has absorption rates of only 4 to 10%.

An important property of brick that critically affects bond strength is the *initial rate of absorption* (IRA), or *suction*. High-suction brick absorbs excessive water from the mortar, which weakens bond, retards cement hydration, and results in water-permeable joints. Optimum bond and minimum water penetration are produced with units having initial rates of absorption between 5 and 25 gram/minute/30 sq in. at the time they are laid (see Fig. 3-30). The requirement is based on the area of the bed surface of a modular brick being approximately 30 sq in. Brick with an IRA greater than 30 gram/minute/30 sq in. should be thoroughly wetted by spray, dip, or soaker hose a day or so before installation so the moisture is fully absorbed but the surfaces are dry to the touch before the units are laid. Since IRA can be controlled by this means, it is not covered in ASTM requirements. It should, however, be included in project specifications.

Saturation coefficient, or *C/B ratio*, is a measure of the relationship of two aspects of water absorption: the amount freely or easily absorbed and the amount absorbed under pressure. The former (*C*) is determined by the 24-hour cold water absorption test, and the latter (*B*) by the 5-hour boil absorption test. For Grade SW brick, the ratio must be 0.78 or less to meet ASTM standards. The *C/B* ratio determines the volume of open pore space remaining after free absorption has taken place. This is important under severe weathering conditions when a unit has taken in water, which must have room to expand if frozen in order to avoid damage to the clay body. The theory does not apply to hollow masonry units or to certain types of de-aired products. In those cases, strength and absorption alone are used as measures of resistance to frost action.

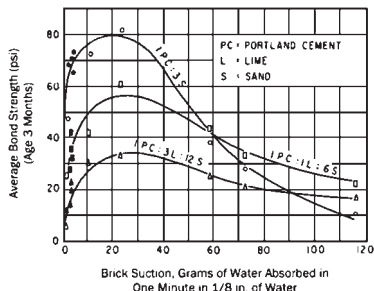


Figure 3-30 Relationship between bond strength and initial rate of absorption (IRA). (From Ritchie and Davison, Cement-Lime Mortars, National Research Council, Ottawa, Ontario, Canada, 1964.)

3.4.4 Durability

The durability of clay masonry usually refers to its ability to withstand freezing in the presence of moisture, since this is the most severe test to which it is subjected. Compressive strength, absorption, and saturation coefficient are evaluated together as indicators of freeze-thaw resistance, since a value cannot be assigned specifically for this characteristic.

Resistance to wear and abrasion is an important aspect of durability for brick paving, and for the lining of structures that will carry sewage, industrial waste, and so on. Abrasion resistance is closely associated with the degree of burning, and ranges from under-burned salmon brick at the low end to vitrified shale and fire clay at the high end. The stronger the unit and the lower the absorption, the greater the abrasion resistance will be. In salvaged brick or imported brick, under-burned units are easily detected without sophisticated laboratory equipment or procedures. Extremely soft units are easily scratched or scored with a coin, cut with a knife, or even broken by hand (see Fig. 3-31). Bricks conforming to ASTM standards, however, are high-quality products with proven records of performance in service.

3.4.5 Expansion Coefficients

Clay masonry products have *coefficients of thermal expansion* which range from 0.0000025 in./°F for fire clay units to 0.0000036 in./°F for surface clay and shale units. This minute thermal expansion and contraction is reversible. Moisture expansion, however, is not reversible. Fired bricks are at their smallest dimension when leaving the kiln. All natural moisture and the water added for forming and extrusion are evaporated during the firing process. Once fired, clay products begin to rehydrate by absorbing atmospheric moisture, causing irreversible expansion of the units. Test results have assigned a value of 0.02 to 0.07% for the *coefficient of moisture expansion*. Both vertical and horizontal expansion joints must be provided in the masonry to permit this movement. Severe problems can develop when clay masonry



Figure 3-31 Under-burned bricks are easily scratched or scored with a coin, cut with a knife, or broken by hand. (Photos courtesy Brick Institute of Texas.)

expansion is restrained, particularly by concrete elements which have an opposing potential for shrinkage. Jointing details must provide flexible anchorage to accommodate such differential movement. (Refer to Chapter 9.)

3.4.6 Fire and Thermal Resistance

Masonry fire resistance and thermal performance are both determined by mass. The characteristics of the individual units are not considered, but ratings are established for finished wall assemblies. Detailed analysis of these properties is covered in Chapter 8.

3.4.7 Acoustical Characteristics

The density of clay masonry determines its acoustical characteristics. Although sound absorption is almost negligible, the heavy mass provides excellent resistance to the transmission of sound through walls. This suggests best use as partitions or sound barriers between areas of different occupancy. Where higher absorption is required in addition to sound isolation, special acoustical units are used. Acoustical tile was developed to offer 60 to 65% absorption. The unit is a structural facing tile with a perforated face shell. The adjacent cell(s) are factory-filled with a fibrous glass pad. The perforations may be round or slotted and arranged in random or uniform patterns. The tile itself is of loadbearing quality, may be glazed or unglazed, and otherwise exhibits the same properties and characteristics of structural clay facing tile manufactured in accordance with ASTM C212 or C126. (Refer to Chapter 8.)

3.4.8 Colors and Textures

Brick and tile are available in an almost unlimited variety of colors and textures. They may be standard items or custom units produced for unique project requirements. Natural clay colors can be altered or augmented by the introduction of various minerals in the mix, and further enhanced by application of a clear, lustrous glaze. Ceramic glazed finishes range from the bright primary colors through the more subtle earth tones in solid, mottled, or

blended shades. Glossy, matte, and satin finishes, as well as applied textures, add other aesthetic options (see Fig. 2-3).

3.5 ADOBE MASONRY

Adobe masonry is constructed of large, sun-dried bricks made from clay, sand, silt, and water with additives sometimes used as stabilizers. There are no industry standards for reliable soil selection. The National Parks Service performed testing on a number of historic and contemporary adobe structures and found a wide range of soil types, clay contents, and particle sizes. The Uniform Building Code (UBC) Standard 21-9, *Unburned Clay Masonry Units and Standard Methods of Sampling and Testing Unburned Clay Masonry Units*, requires soil with not less than 25% nor more than 45% of material passing a No. 200 mesh sieve, and containing sufficient clay to bind the particles together. Soil can be tested for approximate composition. Place a soil sample in a jar and then fill the jar with water. Shake the mixture and allow it to settle until the water at the top is clear. The resulting bands of coarser aggregates at the bottom of the jar, and sand, silt, and clay on top will indicate the approximate proportions of the constituent materials. Another field test for clay content and plasticity is the rope test. Mix a sample of soil with a small amount of water to make a stiff lump of mud. Roll the mud by hand into a rope-like shape. The rope should bend easily without breaking if the soil composition is suitable for making adobes.

Soils more often contain too much rather than too little clay, and can be modified by adding sand, straw, hay, or other vegetable fibers. This tempering process helps minimize the shrinkage cracking which can be caused by using soils with too much clay. Any sand that is added should be sharp, angular manufactured sand rather than natural rounded bank run particles. The proper proportions are usually determined by trial and error and tested by making sample bricks. There is generally a broad tolerance range on sand/clay proportions which produce good-quality adobe bricks.

Adobe mixtures are seldom specified. Most often, test bricks are made, dried, and checked. A good mix of clay, sand, silt, and water should be easy to hand-mix by shovel or hoe, should not fall apart when turned into a small mound, should slip free of forms, and should not warp, curl, or crack as the brick dries. The dried brick should not chip or break off at corners when moved, and should be able to withstand 10 to 15 minutes of light to moderate rain with little or no erosion or washing. When broken in half, a unit should exhibit uniform color throughout. Expansive clays such as montmorillonite should be avoided because of their shrink/swell potential, although it can be minimized by adding straw to the mix. Kaolin clays are non-expansive.

Traditional additives or stabilizers for adobe have ranged from straw to horsehair, grass, and pine needles. These materials were used primarily as tensile reinforcement to resist shrinkage cracking. More recently, other chemical materials have been used to increase moisture resistance. Emulsified asphalt is most commonly used, mixed with the adobe at a rate of 5 to 8% by weight. The asphalt emulsion coats the clay particles to reduce natural moisture absorption. Portland cement is also sometimes added to adobe soils. This will increase the compressive strength of the bricks, but will not improve moisture resistance. Lime should not be used as a soil additive.

3.5.1 Manufacturing Adobe

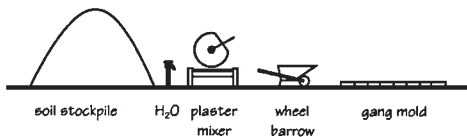
Adobe bricks are usually rectangular in shape with a length that is twice the width. Sizes range from 4 in. high \times 9 \times 18 in. to 6 in. high \times 12 \times 24 in., but the latter units are very heavy. In New Mexico, a majority of adobe

bricks are cast at 4 in. high \times 10 \times 14 in. and weigh about 30 lb each. The maximum practical weight for handling by a single person is about 40 lb.

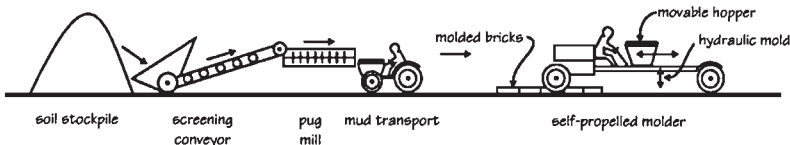
Adobe manufacturing can range from small, on-site operations to fully or partially mechanized commercial operations (see Fig. 3-32). A two-person crew can turn out 300 to 400 bricks per day by hand. A fully mechanized operation may produce as many as 20,000 bricks per day using a pug mill for mixing, self-propelled molding and screeding machines, and permanent steel molds.

Molds are most commonly made of wood, but can also be of metal. Wood molds must be oiled or wetted to prevent sticking. All molds must be cleaned frequently to remove dried mud. The molds are laid on flat or leveled ground, which can be covered with sand to prevent the bricks from sticking to the ground. The consistency of the mud mix may be either damp or liquid, depending on the method of mixing and the number of molds available. Liquid mixes generally produce stronger and more dense bricks, but since initial set takes longer, it will be necessary to use large gang molds in order to produce in sufficient quantities (see Fig. 3-33). Molds can be removed from damp, stiff mixes more quickly and reused right away. After the mold is filled, the top is leveled and screeded. Stiff mixes may require tamping to assure complete filling of the mold corners.

After the molds have been removed, the bricks must remain flat until they are dry enough to handle. This initial drying may take anywhere from 2 to 3 days in the summer or several weeks in the winter, depending on the moisture content of the mix. During this period, the units should be protected from rain by covering as necessary with tarps or plastic sheeting. The covers will retard the drying and curing process, though, so they should be removed as soon as possible. When the bricks are dry enough to be handled without breaking, they are set on edge to expose both large surfaces for better drying.



SEMI-MECHANIZED ADOBE PRODUCTION



FULLY MECHANIZED ADOBE PRODUCTION

Figure 3-32 Adobe production. (From Paul Graham McHenry, Jr., *Adobe and Rammed Earth Buildings*, 1984.)

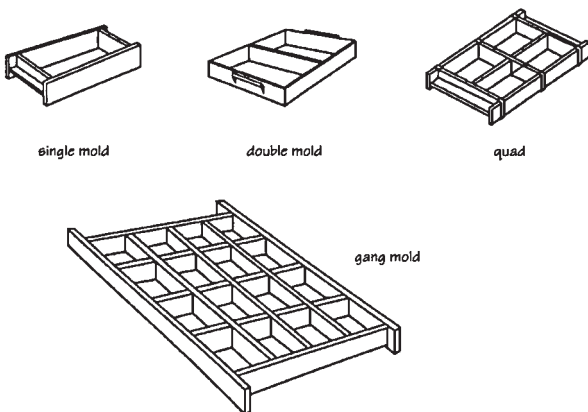


Figure 3-33 Adobe molds. (From Paul Graham McHenry, Jr., *Adobe and Rammed Earth Buildings*, 1984.)

At this stage, any cleaning or trimming that is necessary can be performed. The length of the drying and curing period will vary, depending on the size and thickness of the unit and the weather conditions. Freezing temperatures during the drying period can destroy the units, and many U.S. companies suspend production during the winter months. After the bricks have dried for at least 7 days, they are stacked on edge two units deep and three or four courses high. The top of the stack should be protected from rain, but the sides left open. With such protection, the units can remain in storage in this manner for extended periods of time.

3.5.2 Physical Properties and Characteristics

Finished bricks can be simply tested in a couple of different ways. The point of a knife blade should not penetrate the surface of a fully dried brick more than about $\frac{1}{8}$ in. If the unit appears dry on the surface but is still damp on the inside, the knife blade will penetrate deeply. A finished brick can also be dropped on its corner from a height of about 3 ft. A thoroughly dried and cured brick of good quality will suffer little or no damage other than minor chipping at the corner. If the unit is not totally dry, it will shatter. If the soil was not properly and thoroughly mixed to homogeneity, it will split along the planes of weakness.

UBC Standard 21-1, *Building Brick, Facing Brick and Hollow Brick (Made From Clay or Shale)*, requires that finished adobe bricks have the minimum physical properties indicated in Fig. 3-34.

Unit Type	Minimum Net Area Compressive Strength		Water Absorption (By Weight)	Moisture Content (By Weight)	Minimum Modulus Of Rupture	
	Average of Five Tests	Individual Unit			Average of Five Tests	Individual Unit
Unburned clay masonry	300	250	2.5%	4%	50	35

Figure 3-34 Physical requirements for adobe masonry units. (From *UBC Standard 21-1, ICBO, 1994.*)

3.5.3 Adobe Mortar

Although adobe can be laid with a portland cement–lime mortar, it is more common to use an adobe mortar made from the same soil mix as the units. When laid with adobe mortar, a wall that is subjected to cracking stresses will crack monolithically through the units. When laid with a traditional masonry mortar, the same wall will crack at the mortar joints. Maximum aggregate size in adobe mortar should be $\frac{1}{4}$ in., and the mortar should be thoroughly soaked and mixed to prevent clay balling.

This page intentionally left blank.

4

CEMENTITIOUS MASONRY UNITS

Cementitious masonry units are hardened by chemical reactions rather than by ceramic fusion. This group includes concrete brick and block as well as sand-lime brick and cast stone. The majority of these units are classified as solid, having less than 25% core area in relation to the gross cross section in the bearing plane. Concrete block, however, typically has 40 to 50% coring and is thus defined as hollow.

- 4.1 CONCRETE BRICK** Concrete brick is produced from a controlled mixture of portland cement and aggregates in sizes, colors, and proportions similar to clay brick (see Fig. 4-1). It is governed by the requirements of ASTM C55, *Standard Specification for Concrete Building Brick*, and can be loadbearing or non-loadbearing. Aggregates include gravel, crushed stone, cinders, burned clay, and blast-furnace slag, producing both normal-weight and lightweight units. Coring or “frogging” may be used to reduce weight and improve mechanical bond.

Grading is based on strength and resistance to weathering. Grade N provides high strength and maximum resistance to moisture penetration and frost action. Grade S has only moderate strength and resistance to frost action and moisture penetration.

Concrete mixes may be altered to produce a slight roll or slump when forms are removed, creating a unit similar in appearance to adobe brick. Color is achieved by adding natural or synthetic iron oxides, chromium oxides, or other pigments to the mix, just as in colored mortar (refer to Chapter 2). ASTM standards do not include color, texture, weight classification, or other special features. These properties must be covered separately in the project specifications.

- 4.2 SAND-LIME BRICK** Calcium silicate brick, or sand-lime brick, is made with sand or other siliceous material and 5 to 10% hydrated lime, then steam-cured in high-pressure



Figure 4-1 Concrete and calcium silicate (sand-lime) brick.

autoclaves at 400°F for up to 8 hours. In the autoclave, the lime reacts chemically with the silica to form hydrated calcium silicate, a strong and durable cementing agent that binds the sand particles together.

Calcium silicate brick is widely used in industrial countries where suitable siliceous sands are more readily available than clay. In the United States, calcium silicate brick has been produced since the early 1900s. The units have a natural near-white color with a slight yellow, gray, or pink tint, depending on the color of the sand used. With the addition of natural or synthetic pigments, dark earth tones, reds, blacks, and light pastel colors can be produced, including blues and greens. Two colors can be blended for a swirled mixture, or units can be dipped in acid after hardening to intensify their color. Unit surfaces are smooth and uniform—the finer the sand particles, the smoother the surface. Texture is produced by sandblasting, mechanical brushing, or adding flint aggregates to the mix. Splitting hardened units produces a natural rockface finish.

Sand-lime brick is used extensively in Europe, Russia, Australia, the Middle East, Mexico, and the United Kingdom. Most U.S. building codes permit its use in the same manner as clay brick for both loadbearing and non-loadbearing applications. ASTM C73, *Standard Specification for Calcium Silicate Face Brick (Sand-Lime Brick)*, includes grading standards identical to those for clay face brick for severe weathering (Grade SW) and moderate weathering (Grade MW). Compressive strength minimums are 4500 and 2500 psi, respectively, and absorption rates are 10 and 13%, respectively. Strength and hardness are increased as carbon dioxide in the air slowly converts the calcium silicate to calcium carbonate.

Alternate wetting and drying, and repeated freeze-thaw cycles, have little effect on calcium silicate brick, and efflorescence is not a problem because the raw materials do not ordinarily contain soluble sulfates or other salts. Sand-lime brick is also resistant to attack when in contact with soils containing high levels of sulfates. As with all limestone-based products, the sulfur dioxide in heavily polluted air affects the brick after 20 to 30 years. And like cement-based products, calcium silicate brick is not resistant to acids or repeated exposure to saturated saltwater solutions.

At 100 to 300 lb/cu ft, density is similar to that of a medium-density clay brick. Using expanded aggregates reduces density to about 80 lb/cu ft, and coring or perforations can reduce overall weight. Both sound transmission and fire resistance are similar to clay brick, but ordinary calcium silicate units can also be used in flues, chimney stacks, and other locations requiring moderate refractories.

Calcium silicate units are produced in modular brick sizes as well as larger blocks measuring from 8 × 8 × 16 in. to face sizes of 12 × 24 or 24 × 36 in. with a bed thickness of 4 to 12 in. The larger block units are widely used in some European countries to increase labor production. Single- or multiwythe walls can be erected by using small, transportable electric cranes and mechanical grippers. The units are self-aligning, either by tongue-and-groove slots or by mechanical plugs, and vertical reinforcing steel can be incorporated through core holes and end grooves.

4.3 CAST STONE

Cast stone is most widely used as an accessory for masonry construction in the form of lintels, sills, copings, and so on (see Fig. 4-2). Some manufacturers also produce simulated stone products designed for use as facing materials. The shape of the mold used for casting will determine the appearance of the unit. Any shape that can be carved in natural stone can probably also be formed in cast stone.

Cast stone is defined as an architectural precast concrete building unit intended to simulate natural cut stone. Unlike “simulated stone” produced in random sizes as rubble or cleft-face quarried stone (see Fig. 4-3), cast stone exhibits the same finish as a good grade of limestone or brownstone which has been cut or honed.

The French made lintels and door trim out of cast stone as early as the twelfth century. Today, cast stone is made of a carefully proportioned mix containing natural gravel, washed and graded sand, and crushed and graded stone such as granite, marble, quartz or limestone meeting requirements of ASTM C33, *Standard Specification for Concrete Aggregates*. White portland cement usually is used to produce light colors and color consistency, although gray cement and color pigments are sometimes blended with the white cement. Because a rich cement-aggregate ratio of 1:3 is normally used, cast stone properly cured in a warm, moist environment is dense, relatively impermeable to

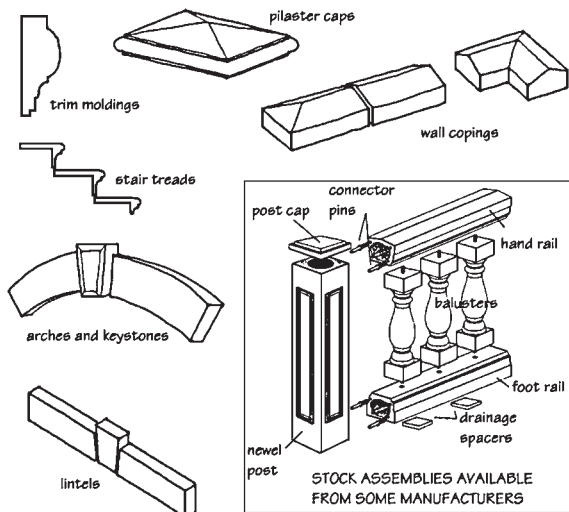


Figure 4-2 Typical cast stone elements used with stone and unit masonry.



Figure 4-3 Simulated stone made to resemble natural rubble stone is not the same strength and quality as architectural cast stone.

moisture, and has a fine-grained, natural texture. ASTM C1364, *Standard Specification for Architectural Cast Stone*, prescribes minimum physical requirements (see Fig. 4-4), dimensional tolerances, and permissible color variations. Cast stone is relatively heavy at 144 lb/cu ft, and at 6500 psi, compressive strength is higher than ordinary cast-in-place concrete.

Cast stone is made by two methods. In the wet-cast method, stone is cast in much the same way as other architectural precast concrete. If most of the stone surfaces are to be flat, the concrete is vibrated with external vibrators. If the stone is highly ornamental, it is vibrated with internal vibrators. The stone is then cured in the mold until the next day when it is stripped. In the dry-tamp method of manufacture, a pneumatic machine is used to ram and vibrate moist, zero-slump concrete against rigid formwork. When the concrete is densely compacted, it is removed from the form and left to cure overnight.

To ensure that the stone undergoes little change in appearance because of weathering, the outer surface of mortar is removed to expose the fine aggregates. Hydrochloric acid is used to etch the surface because it produces the most brilliant colors and leaves a surface that stays clean. Sandblasting and chemical retarders, which are normally used to finish architectural precast, are not used on cast stone because they dull the aggregates and cause the loss of fine detail.

Although some cast stone manufacturers produce and stock standard items of architectural trim such as balusters, door pediments, and balcony rails, cast stone is more often custom designed and fabricated for each project. For greatest economy, design shapes should be tailored to the fabrication process. Projections should be slightly angled rather than flat to facilitate removal of the molds. The length of projections should not exceed their thickness. Transitions from a finished to an unfinished surface should be sharp angles rather than feathered edges. L- and U-shaped sections are vulnerable to breakage during fabrication and shipment. Returns should be formed instead by butt jointing or mitering two pieces.

Architectural Cast Stone		
Minimum Compressive Strength (psi)	Maximum Cold Water Absorption (% Weight)	Maximum Boiling Water Absorption (% Weight)
6,500	6	10

Figure 4-4 Minimum physical requirements for architectural cast stone (based on ASTM C1364).

4.4 AUTOCLAVED AERATED CONCRETE BLOCK

Block made from autoclaved aerated concrete (AAC) has excellent insulating, sound-damping, and fire-resistive properties (Fig. 4-5). A 4-in.-thick wall has a fire rating of 4 hours and a 6-in. wall has a 6-hour rating. *R* values are higher than for any other type of masonry. Compressive strength is relatively low, however, and moisture absorption high. The exterior surface must be protected from wetting by a cladding (such as stucco) or breathable acrylic coating (minimum 5 perms). The units weigh only one-fourth to one-third as much as normal concrete block, but not because of lightweight aggregates. The mix contains portland cement, lime, sand or fly ash, and aluminum powder, with water added to form a slurry. Large steel vats are used as molds. A chemical reaction releases hydrogen gas and generates heat, which causes the concrete to expand and set in cellular form. Smaller units are wire-cut or saw-cut from the large forms and curing is completed under steam pressure in autoclave kilns.

AAC block has little size variation, so it can be laid with standard $\frac{3}{8}$ -in. mortar joints or with joints that are only $\frac{1}{8}$ in. thick. It can be used for bearing walls in low-rise construction, for interior partition walls, as lightweight fireproofing for steel structural frames, and as acoustical partitions. AAC block can be cut or sawed with ordinary woodworking tools and is also nailable. Two ASTM standards for AAC have been published, and others are in development. ASTM C1386, *Specification for Precast Autoclaved Aerated Concrete (PAAC) Wall Construction Units*, and ASTM C1452, *Specification for Reinforced Autoclaved Aerated Concrete Elements*, cover both physical properties and testing methods.

4.5 CONCRETE BLOCK

Of the cementitious masonry products marketed in this country, concrete block is the most familiar and most widely used. Aggregates determine the weight of the block and give different characteristics to the units. Lightweight aggregates reduce the weight by as much as 20 to 40% with little or no sacrifice in strength. Specifications for aggregates are covered in ASTM C33, *Standard Specification for Concrete Aggregates*, and ASTM C331, *Standard Specification for Lightweight Aggregates for Concrete Masonry Units*. Weight classifications are based on density of the concrete and are subdivided as follows: normal-weight units are those whose concrete mix weighs 125 lb/cu ft or more; medium-weight, between 105 and 125 lb/cu ft; and lightweight, less than 105 lb/cu ft.

Some of the more commonly used aggregates are listed in Fig. 4-6 along with the concrete unit weight and weight classifications. Exact individual unit weights depend on the coring design of the block and the percentage of solid volume and voids. An ordinary $8 \times 8 \times 16$ -in. unit weighs more than 40 lb when made from the more dense aggregates, and 25 to 35 lb when made from the lighter aggregates. Manufacturers can supply information regarding exact weight of their products, or the figures may be calculated if the percent of solid volume is known. Both heavy and lightweight block can be used in any

Typical Properties of AAC Block						
AAC Strength Class	Compressive Strength (psi)	Density (pcf)	R-Value for Thickness Listed			
			6 in.	8 in.	10 in.	12 in.
AAC2	360	25	7.59	10.13	12.66	15.19
		31	6.25	8.33	10.42	12.50
AAC5	725	31				
		37	5.22	6.96	8.70	10.43
		44	5.22	6.96	8.70	10.43
		50				
AAC6	1090	37				
		44	5.22	6.96	8.70	10.43
		50				

Figure 4-5 Properties of autoclaved aerated concrete block.

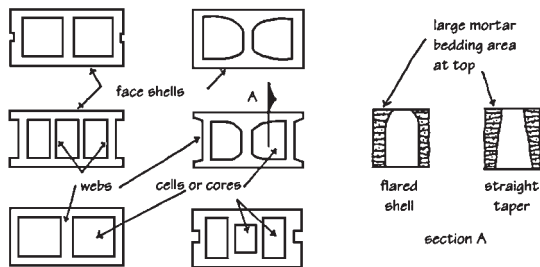
Effect of Aggregate on Weight and Physical Properties						
Classification	Aggregate	Unit Weight of Concrete (pcf)	Average Weight of 8 x 8 x 16 Unit (lb)	Net Area Compressive Strength (psi)	Water Absorption (lb/cu.ft of concrete)	Thermal Expansion Coefficient (per °F x 10 ⁻⁴)
Normal weight	Sand and gravel	135	38	2200-3400	7-10	5.0
	Crushed stone	135	38	2000-3400	8-12	5.0
Medium weight	Air-cooled slag	120	34	2000-2800	10-15	4.6
Light weight	Coal cinders	95	27	1300-1800	12-18	2.5
	Expanded slag	95	27	1300-2200	12-16	4.0
	Scoria	95	27	1300-2200	12-16	4.0
	Expanded clay, shale, and slate	85	24	1800-2800	12-15	4.5
	Pumice	75	22	1300-1700	13-18	4.0

Nominal Size (in.)	Average Weight of Concrete Masonry Units (lbs.)						
	Concrete Density (pcf)						
	80	90	100	110	120	130	140
4 x 8 x 16	14.5	16.5	18.0	20.0	22.0	23.5	25.5
6 x 8 x 16	17.0	19.0	21.5	23.5	25.5	27.5	30.0
8 x 8 x 16	22.5	25.0	28.0	30.5	33.5	36.0	39.0
10 x 8 x 16	27.5	31.0	34.5	37.5	41.0	44.5	48.0
12 x 8 x 16	31.0	35.0	39.0	43.0	47.0	50.5	54.5

Figure 4-6 CMU aggregate type, unit weight, and unit properties.

type of construction, but lightweight units have higher fire, thermal, and sound resistance. Choice of unit will depend largely on local availability and project design requirements. Two kinds of concrete block are recognized—ASTM C90, *Standard Specification for Loadbearing Concrete Masonry Units*, and ASTM C129, *Standard Specification for Non-Loadbearing Concrete Masonry Units*.

Units defined as solid must have a minimum of 75% net solid area. Although the industry has standardized exterior dimensions of modular units, no such standardization exists for the number, size, or configuration of cores. Coring design and percent of solid volume vary, depending on the unit size, the equipment, and the methods of the individual manufacturers. For structural reasons, ASTM standards for loadbearing units specify minimum face shell and web thickness, but these stipulations do not apply for non-loadbearing units. Although minimum face shell and web thickness will not necessarily correspond to actual dimensions for all units, they can be used to estimate properties for preliminary design (see Fig. 4-7).



Minimum Required Face Shell and Web Thickness for Loadbearing (ASTM C90 Only) Concrete Masonry Units			
Nominal Width of Unit (in.)	Minimum Face Shell Thickness [†] (in.)	Web Thickness	
		Minimum Web Thickness [†] (in.)	Minimum Equivalent Web Thickness [‡] (in./linear ft.)
3 and 4	3/4	3/4	1-5/8
6	1	1	2-1/4
8	1-1/4	1	2-1/4
10	1-3/8 1-1/4 [§]	1-1/8	2-1/2
12	1-1/2 1-1/4 [§]	1-1/8	2-1/2
Any width unit solidly grouted	5/8	—	—

[†] Average of measurements on three units, taken at thinnest point.

[§] Allowable design load must be reduced in proportion to reduction in face shell thickness.

[‡] Sum of measured thickness of all webs, multiplied by 12, and divided by length of unit.

(Copyright ASTM, 100 Barr Harbor Drive, West Conshohocken, PA 19428. Reprinted with permission.)

Figure 4-7 Unit coring and minimum face shell thickness.

4.5.1 Coring

Block is produced in two-core and three-core designs and with smooth or flanged ends (see Fig. 4-7). Two-core designs offer several advantages, including a weight reduction of approximately 10% and larger cores for the placement of vertical reinforcing steel and conduit. In addition, the thickened area of the face shell at the center web increases tensile strength and helps to reduce cracking from drying shrinkage and temperature changes. Accurate vertical alignment of both two-core and three-core designs is important in grouted and reinforced construction. End designs of block may be smooth or flanged, and some also have a mortar key or groove for control joints and jamb units. Smooth face ends must be used for corner construction, piers, pilasters, and so on. The cores of hollow units are usually tapered, with the face-shell thickness wider at the top than at the bottom of the unit. This facilitates form removal, provides a larger bedding area for mortar, and allows a better grip for the mason. Minimum thickness required by ASTM standards for loadbearing units refers to the narrowest cross section, not an average thickness of top and bottom. Since compressive strengths of hollow units are established on the basis of gross area, and fire-resistance ratings on equivalent solid thickness, these details of unit design become important in determining actual ratings for a particular unit.

Hollow concrete masonry units (CMUs) are more widely used than solid units because of reduced weight, ease of handling, and lower cost. Most hollow blocks have core areas of 40 to 50%, leaving a net solid volume of 50 to 60%. Some concrete brick manufacturers have begun to capitalize on this economy by producing a cored “through-the-wall” unit that has an increased thickness of 8 in., but maintains the typical face dimensions of brick. They may be classified as either solid or hollow depending on the percentage of voids created.

4.5.2 Grading and Moisture Content

Unlike concrete brick, concrete block no longer has grade classifications. Until recently, however, two types of concrete block were recognized, based on moisture content of the units. The limits on moisture content for some units were based on efforts to minimize shrinkage cracking. Since moisture content was difficult to control at the construction site, NCMA has developed new guidelines for crack control joints and ASTM has eliminated the type designation from its standards. Refer to Chapter 9 for a discussion on controlling movement and cracking in masonry construction.

4.5.3 Sizes and Shapes

Concrete masonry units are governed by the same modular standards as clay masonry products. The basic concrete block size is derived from its relationship to modular brick. A nominal $8 \times 8 \times 16$ -in. block is the equivalent of two modular bricks in width and length, and three brick courses in height. Horizontal ties may be placed at 8- or 16-in. vertical intervals with either brick or structural clay tile facing. These are nominal dimensions that include allowance for a standard $\frac{3}{8}$ -in. mortar joint. Concrete brick dimensions are the same as for clay brick, but fewer sizes are generally available. Some variation in face size of standard concrete block stretcher

units has been introduced to increase productivity on the job. Both the 12-in.-high \times 16-in.-long and the 8-in.-high \times 24-in.-long units have 50% larger face area. To compensate for the additional size, lighter-weight aggregates are used to yield an 8-in.-thick unit weighing only 33 lb (less than a normal-weight 8 \times 8 \times 16-in. block). Each of the larger units can be laid as easily as a standard block, but covers 50% more wall area. These oversize units, however, are not typical. Size variation in most concrete block is limited to 2-in. incremental widths of 4 to 12 in., with a standard face size of 8 \times 16 in. (see Fig. 4-8). Half-lengths and half-heights are available for special conditions at openings, corners, and so on. A number of special shapes have been developed for specific structural functions, such as lintel blocks, sash blocks, pilaster units, and control joint blocks (see Fig. 4-9). Terminology is not fully standardized, and availability will vary, but most manufacturers produce and stock at least some of the more commonly used special items. In the absence of such shapes, however, standard units can be field cut to accommodate many functions.

Standard utility block or “gray block” is not typically used as an exterior finish. Gray block is most often used as the backing wythe in masonry cavity walls and as interior partitions and foundation walls. If it is exposed to the weather, it should be protected by an acrylic or cement-based paint or stucco finish.

Architectural concrete block is made in colors, patterns, and textures more suitable for exterior finishes, but it absorbs water as readily as gray block. Integral water-repellent admixtures and field-applied water repellents are used to reduce absorption, but these treatments cannot protect against moisture intrusion through cracks or bond line separations at the mortar joints. Any wall with an exterior masonry facing must be designed to effec-

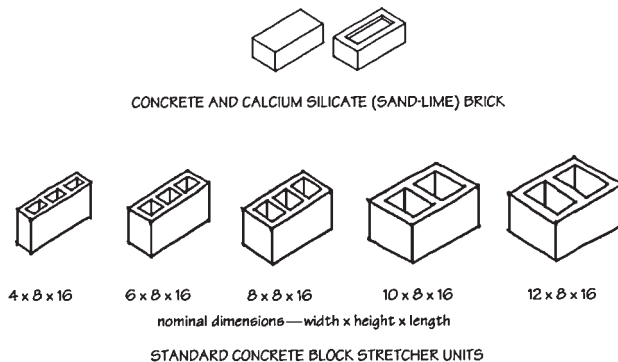


Figure 4-8 Basic concrete masonry unit sizes and shapes.

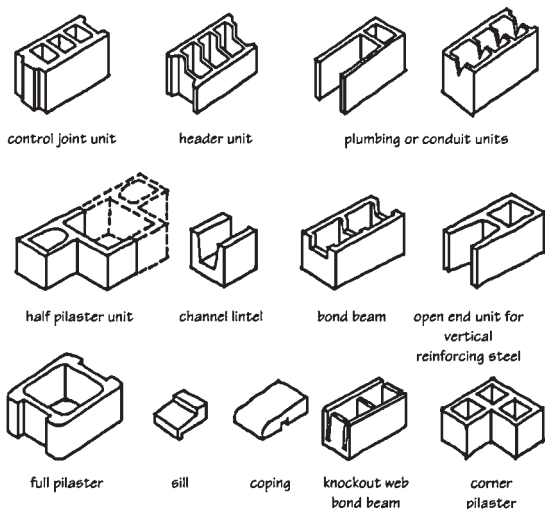


Figure 4-9 Special-shape CMUs.

tively drain moisture that penetrates the wall. When used in a properly designed drainage wall, architectural block provides a unique appearance, with texture and scale very different from brick. Not all of the patterns and textures shown in *Fig. 4-10* are available from every block manufacturer. The most common architectural blocks are the split-face, ribbed and bur-nished (see *Fig. 4-11*).

4.6 SPECIAL UNITS

Proprietary specialty units include flashing blocks, angled units for making 45° corners and intersections, and special block for laying curved walls. Another proprietary design incorporates channels in the block webs to accommodate reinforcing bars and hold them in place without the need for spacers. Still others offer cornice, sill and water table units, inspection blocks for grouting, angled keystone block for arches, and others (see *Fig. 4-12*). Specialty blocks are usually patented designs and may not be available in all areas. Custom CMU designs were produced when architectural concrete block were first being introduced to the market (see *Figs. 4-13 and 4-14*). The cost of custom-designed units, however, is prohibitive on all but the largest projects where the quantity of units needed can offset the cost of producing custom molds.

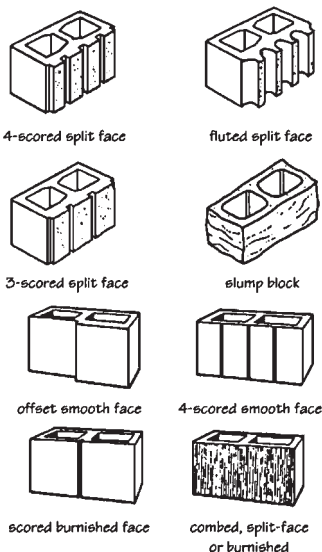


Figure 4-10 Architectural concrete block comes in a variety of colors and textures.

4.6.1 Screen Block

Many decorative effects can be achieved through various CMU surface treatments. Perforated screen blocks are available in several patterns and can be used as sun screens, ornamental partitions, and exterior sound baffles for damping low-frequency airborne noise (see *Fig. 4-15*). Ordinary concrete blocks are typically laid with the hollow cores oriented vertically. Screen blocks, however, are laid with the hollow cores oriented horizontally, which yields a lower compressive strength for axial loads. Some common screen block designs are shown in *Fig. 4-16*, along with their relative compressive strength. Screen blocks are non-loadbearing, but they must be strong enough to carry their own weight and the weight of the units above them.

4.6.2 Prefaced Units

Glazed surfaces may be applied to concrete brick or block as well as to sand-lime brick. Glazes may consist of epoxy, polyester, ceramic, porcelainized, or



Figure 4-11 Ribbed, split-face, and burnished concrete block.

mineral glazes, or cementitious finishes. All applied surfaces must meet the requirements of ASTM C744, *Standard Specification for Prefaced Concrete and Calcium Silicate Masonry Units*, in tests of imperviousness, abrasion, stain resistance, chemical resistance, and fire resistance as well as crazing and adhesion of facing material to unit (see Fig. 4-17). A thermosetting, resinous coating combined with specially treated silica sand, pigments, and/or ceramic colored granules is applied to the unit. The minimum requirements for both strength and abrasion are lower for glazed cementitious and concrete products than for glazed clay masonry units. Like glazed clay units, prefaced concrete masonry units combine the functionality of masonry with a hygienic, cleanable surface and a wide palette of color choices. Manufacturing tolerances are only $\pm\frac{3}{16}$ in. so that narrow joints can be used to minimize mortar exposure.

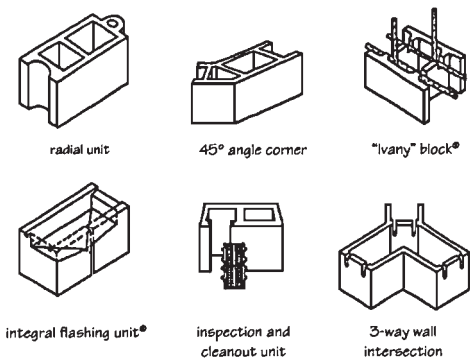


Figure 4-12 Special-purpose concrete masonry units.

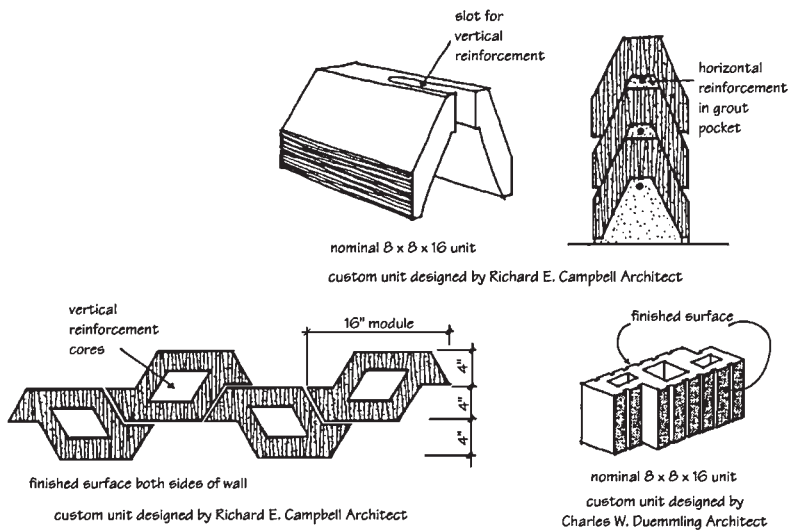


Figure 4-13 Custom-designed concrete block.

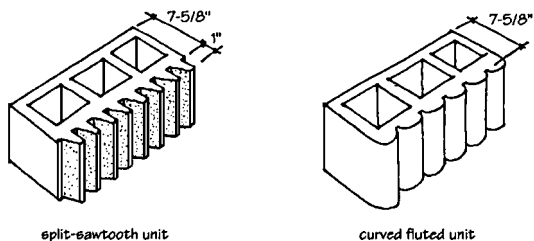


Figure 4-14 Two custom face designs by architect Paul Rudolph. (Photos courtesy National Concrete Masonry Association.)

4.6.3 Paving Units

Two kinds of concrete masonry paving units are available for roadway and parking area surfacing. Solid interlocking units in a number of patterns provide a continuous topping over standard sand and gravel base materials. Open grid blocks permit grass to grow through the perforations while stabilizing the soil, protecting vegetation, and supporting vehicular traffic (see Fig. 4-18). Densely compacted units of 5000- to 8000-psi compressive strength have a high resistance to moisture penetration and great durability in severe weathering conditions. CMU paving systems permit percolation of rainwater back into the soil despite the relative imperviousness of the unit itself. Prevention of excessive runoff is an important environmental consideration for standard installations as well as those where erosion and drainage of surrounding areas may be a problem. Grid units are generally 15 to 18 in. wide, about 24 in. long, and from

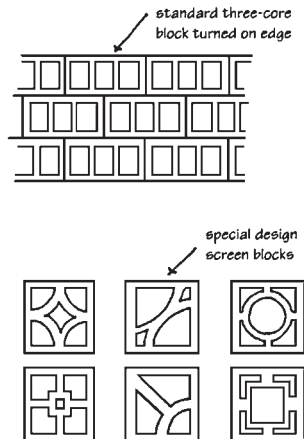


Figure 4-15 Concrete masonry screen block.

4½ to 6 in. deep. Solid units are usually of proprietary design, and sizes and shapes will vary among manufacturers. Thicknesses range from 2½ to 5½ in., depending on the type of service and traffic load anticipated. Heavy-duty performance can be provided for industrial areas and roadways when speeds do not exceed about 40 mph.

ASTM C936, *Standard Specification for Solid Concrete Interlocking Paving Units*, governs abrasion resistance and resistance to freeze-thaw, limits absorption to 5% and sets minimum compressive strength at 8000 psi. ASTM C1319, *Standard Specification for Concrete Grid Paving Units*, limits absorption to 10% and sets minimum net area compressive strength at 5000 psi (see Fig. 4-19).

4.6.4 Segmental Retaining Wall Units

One of the most recent developments in the concrete masonry industry is the dry-stacked, interlocking concrete block retaining wall. Referred to as segmental retaining walls (SRWs), a variety of proprietary units and systems are available (see Fig. 4-20). The systems are designed to step back slightly in each course toward the embankment. Some units interlock simply by their shape, while others use pins or dowels to connect successive courses. The units use high compressive strengths and low absorption characteristics to resist spalling and freeze-thaw damage. Because they are dry-stacked without mortar, segmental retaining wall systems are simple and fast to install. The open joints in SRWs allow free drainage of soil moisture, and the

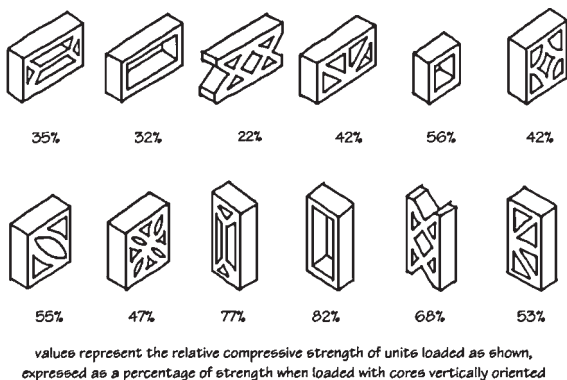


Figure 4-16 Relative compressive strength of concrete masonry screen block when oriented perpendicular to normal bedding.

stepped-back designs reduce overturning stresses. (Refer to Chapter 13 for design and installation requirements.)

4.7 PROPERTIES AND CHARACTERISTICS

CMU physical properties and characteristics fall into a number of structural, aesthetic, and functional categories. The two basic aspects, strength and absorption, have the greatest influence on overall performance. Compressive strength varies with the type and gradation of the aggregate, the water-cement ratio, and the degree of compaction achieved in molding. In general, the lighter-weight aggregates produce slightly lower strength values and have increased rates of absorption (see Fig. 4-21).

4.7.1 Unit Strength

Aggregate size and gradation as well as the amount of mixing water affect compaction and consolidation, and are important determinants of strength. Reducing unfilled voids between particles by 1% with extra compaction may increase block strength by as much as 5%. Higher compressive strengths are generally associated with wetter mixes, but manufacturers must individually determine optimum water proportions to obtain a balance among moldability, handling, breakage, and strength. For special applications, higher-strength units may be obtained from the same aggregates by careful design of the concrete mix and slower curing, increasing net strength ratings to as much as 4000 psi.

Other CMU structural values can be estimated from compressive strength. *Tensile strength* generally ranges from 3 to 5% of net compressive

Requirements for Facing ¹	
Property or Characteristic	Requirement
Resistance to crazing, cracking, or spalling	None when tested in accordance with specified method
Chemical resistance	No change after testing with specified chemicals [†]
Adhesion of facing	No failure of adhesion of facing material at unit compression test failure
Abrasion resistance	Wear index shall exceed 130 when tested in accordance with specified method
Surface burning characteristics	Flame spread less than 25, smoke density less than 50
Color, tint and texture	As specified by purchaser, change less than 5 Delta units when tested in accordance with specified method
Soiling and cleansability	Visible stain not to exceed trace when tested in accordance with specified method Spotting media completely removed when tested in accordance with specified method

¹ Facing of resin, resin and inert filler, or cement and inert filler producing a smooth resinous tile facing.

[†] See table below.

Chemical Resistance	
Chemical	Duration of Test (hr.)
Acetic acid, CH ₃ COOH, 5%	24
Hydrochloric acid, HCl, 10%	3
Potassium hydroxide, KOH, 10%	3
Trisodium phosphate, Na ₃ PO ₄ , 5%	24
Hydrogen peroxide, H ₂ O ₂ , 3%	24
Laundry detergent, 10%	24
Vegetable oil	24
Blue-black ink	1
Ethyl alcohol, industrial denatured, 95%	3

(Copyright ASTM, 100 Barr Harbor Drive, West Conshohocken, PA 19428. Reprinted with permission.)

Manufacturing Tolerances	
Type of Tolerance	Requirement
Size	Total variation from specified dimensions of finished face height and length shall not exceed $\pm 1/16$ in.
Distortion	Distortion of plane and edges of facing from plane and edges of unit, maximum $1/16$ in.
Cracking, chippage	Units shall be sound and free of cracks or other defects which interfere with placement or impair strength. Facing shall be free of chips, crazes, cracks, blisters, crawling, holes, and other imperfections which detract from appearance when viewed from a distance of 5 ft. perpendicular to facing surface using daylight without direct sunlight.

Figure 4-17 Requirements for ASTM C744 precast concrete masonry units.

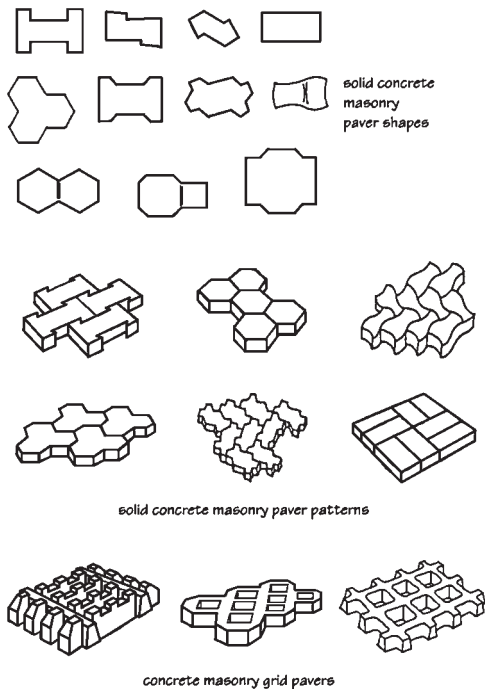


Figure 4-18 Concrete masonry paving units. (From *National Concrete Masonry Association, TEK 11-3, NCMA, Herndon, VA.*)

strength, *flexural strength* from 7 to 10%, and the *modulus of elasticity* from 150 to 600 times the value in compression. For engineering calculations in reinforced masonry construction, exact figures must be computed, but for general design purposes, these rules of thumb give a fairly accurate idea of the properties and capabilities of the block or concrete brick being considered.

4.7.2 Absorption

Water absorption characteristics are an indication of durability in resistance to freeze-thaw cycles. Highly absorptive units, if frozen when permeated with

ASTM C936 Requirements for Solid Concrete Interlocking Paving Units								
Compressive Strength (psi)		Absorption (%)		Freeze-Thaw Resistance, Loss in Dry Mass (%)	Abrasion Resistance		Dimensional Tolerance (\pm in.)	
Average	Individual Unit	Average	Individual		Volume Loss (in ³ /7.75 in ²)	Thickness Loss (in.)	Length or Width	Height
8000	7200	5	7	1.0	0.915	0.118	1/16	1/8

ASTM C1319 Requirements for Concrete Grid Paving Units					
Net Area Compressive Strength (psi)		Maximum Water Absorption (lb/cu.ft)	Minimum Net Area (%)	Web Width (in.)	
Average of 3 Units	Individual Unit			Average of 3 Units	Minimum
5000	4500	10	50	1.00	1.25

Figure 4-19 Minimum requirements for concrete masonry pavers. (Copyright ASTM, 100 Barr Harbor Drive, West Conshohocken, PA 19428. Reprinted with permission.)

water, can be fractured by the expanding ice crystals. A drier unit can accommodate some expansion into empty pore areas without damage. Minimum ASTM requirements differentiate between unit weights because of the effect of aggregate characteristics on this property. Absorption values are measured in pounds of water per cubic foot of concrete. They may range from as little as 4 or 5 lb/cu ft for heavy sand and gravel materials to 20 lb/cu ft for the most porous, lightweight aggregates.

Porosity influences other properties, such as thermal insulation and sound absorption. Increases in these characteristics are often accompanied by an undesirable increase in moisture absorption as well. Pore structure varies for different aggregates and material types and has varying influence on these values and their relationships to one another. Relatively large interconnected pores readily absorb air and sound as well as water, and offer less resistance to damage from freezing. Unconnected or closed pores such as those in structural grade expanded aggregate offer good insulating qualities, and reduced absorption of water and sound. A high initial rate of water absorption, or suction, adversely affects the bond between mortar and unit just as it does in clay masonry. Unlike brick, however, concrete products may not be prewetted at the job site to control suction because of the moisture shrinkage inherent to concrete. Prewetting concrete masonry units could cause excessive shrinkage cracking in the wall. Suction can be controlled only through proper product specification by ASTM standards, and through the use of highly water retentive mortars (i.e., maximum proportion of lime) to ensure the integrity of the bond.

Architectural block is sometimes treated with an integral water repellent to resist soil accumulations and to decrease surface water absorption. Whenever an integral water repellent is used in a concrete masonry product, compatibility and bond with mortar must be considered because the bonding characteristics of the unit are affected. In general, a CMU product that has

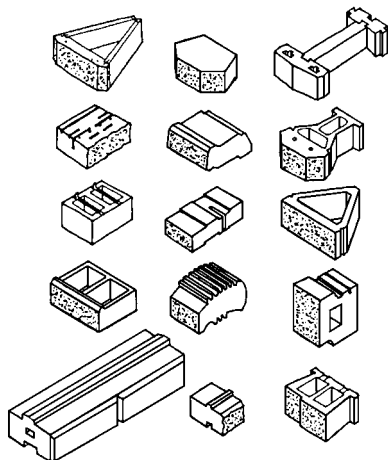


Figure 4-20 A number of proprietary segmental retaining wall (SRW) units are available. (From *National Concrete Masonry Association, Design Manual for Segmental Retaining Walls*, NCMA, Herndon, VA.)

been treated with an integral water repellent requires use of mortar that has compatible chemical admixtures to promote better bond.

4.7.3 Volume Changes

Volume changes in concrete masonry are caused by several things. Moisture shrinkage can be the most damaging because evaporation of residual mixing water from the forming and curing process causes permanent shrinkage. Aged units expand and contract reversibly with changes in moisture content. The different manufacturing techniques described in Chapter 2 bear significantly on this characteristic because of the variations in curing and drying methods. For a given aggregate, shrinkage tendencies due to moisture

Unit	Minimum Compressive Strength (psi)		Maximum Water Absorption (pcf), Average of 3 Units, Weight Classification—Oven Dry Weight of Concrete		
	Average of 3 Units	Individual Unit	Lightweight (less than 105 pcf)	Medium Weight (105 to 125 pcf)	Normal Weight (125 pcf or more)
Loadbearing CMU (ASTM C90)	1900 (net area)	1700 (net area)	18	15	13
Non-Loadbearing CMU (ASTM C129)	600 (net area)	500 (net area)	—	—	—
Concrete Brick (ASTM C55)					
Grade N	3500 (gross area)	3000 (gross area)	15	13	10
Grade S	2500 (gross area)	2000 (gross area)	18	15	13
Calcium Silicate Brick (Sand Lime Brick) (ASTM C73)					
Grade SW	4500 (gross area)	3500 (gross area)	—	—	10
Grade MW	2500 (gross area)	2000 (gross area)	—	—	13

Figure 4-21 Strength and absorption requirements for concrete masonry units. (Copyright ASTM, 100 Barr Harbor Drive, West Conshohocken, PA 19428. Reprinted with permission.)

change can be reduced by as much as half by using high-pressure autoclave curing methods as opposed to low-pressure steam curing.

Small dimensional variations may occur as a result of changes in temperature. These changes, however, are fully reversible, and the units return to their original size after being heated and cooled through the same temperature range. Coefficients of thermal expansion vary with different aggregates and are generally greater than values for clay masonry. As a result, provisions must be made for flexible anchorage and pressure-relieving control joints to prevent random cracking.

Volume changes are also caused by a natural chemical reaction called carbonation. Cured concrete absorbs carbon dioxide from the air, causing irreversible shrinkage. Under certain conditions, the magnitude of this change may nearly equal that of moisture shrinkage. Carbonation stages added to the normal manufacturing process can eliminate many field problems by effectively “preshrinking” the masonry and producing a more dimensionally stable unit.

4.7.4 Fire, Sound, and Heat Resistance

Fire resistance, thermal insulation, and acoustical characteristics are all related to the density of the product. *Fire-resistance* ratings are based on the rate of heat transmission through the unit and the rate of temperature rise on the opposite face rather than on structural failure because no such failure occurs. Ratings are calculated on the equivalent solid thickness of the unit exclusive of voids. For some aggregates and core designs, maximum 4-hour ratings can be obtained with 8-in. hollow units. *Thermal insulation* characteristics vary with aggregate type and density. Exact values may be easily determined from basic information. (Insulating qualities based on engineering calculations are discussed in Chapter 8.)

Acoustical characteristics may be subdivided into two categories: (1) sound absorption and reflectance, which depend primarily on surface texture, and

(2) sound transmission, which is a function of density and mass. Normal-weight or heavyweight units have higher resistance to sound transmission. They will produce walls with higher STC ratings than those of lightweight units because of their resistance to diaphragm action. Sound absorption is higher for coarse, open-textured surfaces with large pores. Sound reflectance is greater for tighter, closer-grained, or painted surfaces with few, if any, open pores. CMUs can absorb from 18 to 68% of the sound striking the face of the wall, with lightweight units having the higher values. Specially designed blocks with slotted face shells provide high absorption by permitting sound waves to enter the cores, where their energy is absorbed by fiber inserts or dissipated through internal reverberation. Noise problems, particularly of middle- and high-frequency sounds, can often be controlled by these units, but they are proprietary products and may not be available in all locations.

4.7.5 Colors

CMU unit colors may be altered through the use of different aggregates, cements, or the integral mixing of natural or synthetic pigments (refer to Chapter 2). Pearl grays, buffs, tans or even whites can easily be produced, offering great versatility within the generic product group. Penetrating stains may also be applied to the finished wall to achieve a uniform color.

5

NATURAL STONE

The earth's hard crust has undergone many changes throughout the millennia of geologic history. The stress and strains, the wearing away by atmospheric forces, by rain, wind, and heat, have produced a great variety of stones differing widely in appearance, but sharing some similarities of composition. All stone is made up of one or more minerals of specific crystalline structure and definable chemical makeup. No two blocks of stone, however, even if quarried side by side, are identical in internal structure or physical and chemical composition.

5.1 GEOLOGICAL CHARACTERISTICS

As a natural, inorganic substance, stone can be categorized by form and geological origin. *Igneous rock* is formed by the solidifying and cooling of molten material lying deep within the earth or thrust to its surface by volcanic action. Granite is the only major building stone of this origin. *Sedimentary rock* such as sandstone, shale, and limestone is formed by waterborne deposits of minerals produced from the weathering and destruction of igneous rock. The jointed and stratified character of the formation makes it generally weaker than igneous rock. *Metamorphic rock* is either igneous or sedimentary material whose structure has been changed by the action of extreme heat or pressure. Marble, quartzite, and slate are all metamorphically formed.

Stone may also be classified by mineral composition. Building stone generally contains as the major constituent (1) silica, (2) silicates, or (3) calcareous materials. The primary silica mineral is quartz, the most abundant mineral on the earth's surface and the principal component of granite. Silicate minerals include feldspar, hornblende, mica, and serpentine. Feldspar may combine with lime or potash to produce red, pink, or clear crystals. Hornblende, combining often with lime or iron, appears green, brown, or black. Mica, with iron or potash, produces clear crystals. Serpentine, in combination with lime, is generally green or yellow in color. The most common silicate building stone is also called serpentine after this mineral. Calcareous minerals include carbonates of lime and magnesia, such as calcite and dolomite, forming limestone, travertine, and marble.

5.2 PROPERTIES

Prior to the twentieth century, stone was the predominant material used in major building construction. It was not only the structural material, but also the exterior and interior finish, and often the flooring and roofing as well. The term “masonry” at one time referred exclusively to stonework, and the “architects” of medieval castles and cathedrals were actually stone masons. Because of its massive weight and the resulting foundation requirements, stone is seldom used today as a structural element in contemporary architecture. It is, however, still widely used as a facing or veneer; in retaining walls, steps, walks, paths, and roads; and as a floor finish, and is enjoying renewed popularity as a roofing material.

Despite their abundant variety, relatively few types of stone are suitable as building materials. In addition to accessibility and ease of quarrying, the stone must also satisfy the requirements of *strength, hardness, workability, porosity, durability, and appearance.*

The strength of a stone depends on its structure, the hardness of its particles, and the manner in which those particles are interlocked or cemented together. Generally, the denser and more durable stones are also stronger, but this is not always true. A minimum *compressive strength* of 5000 psi is considered adequate for building purposes, and the stones most often used are many times stronger in compression than required by the loads imposed on them. Failures from bending or uneven settlement are not uncommon, however, since stone is much stronger in compression than in flexure or shear. Stones of the same type may vary widely in strength, those from one quarry being stronger or weaker than those from another. Thus, the average crushing strength of any type of stone may be misleading because of the wide variation in test results produced by stones within the same classification. The table in *Fig. 5-1* illustrates the ranges typical for several major types of stone. In modern building construction, *shearing strength* in stone is not nearly so important as compressive strength. The allowable unit stress of stone in shear should not be taken at more than one-fourth the allowable compressive unit stress. In *tension*, a safe working stress for stone masonry with portland cement mortar is 15 psi.

Hardness of stone is critically important only in horizontal planes such as flooring and paving, but hardness does have a direct influence on workability. Characteristics may vary from soft sandstone, which is easily scratched, to some stones which are harder than steel. Both strength and hardness are proportional to silica content. *Workability* in this instance refers to the ease with which a stone may be sawed, shaped, dressed, or carved, and will directly affect the cost of production. Workability decreases as the percentage of siliceous materials increases. Limestone, for instance, which contains little silica, is easily cut, drilled, and processed. Granite, however, which consists largely of quartz, is the most difficult stone to cut and finish.

Porosity, the percentage of void content, affects the stone's absorption of moisture, thus influencing its ability to withstand frost action and repeated freeze-thaw cycles. Pore spaces are usually continuous and often form microscopic cracks of irregular shape. The method of stone formation and the speed of cooling of the molten material influence the degree and structure of these voids because of compaction and the possibility of trapped gases. Thus, sedimentary rock, formed in layers without high levels of pressure, is more porous than rock of igneous or metamorphic origin. Closely linked to this characteristic are grain and texture, which influence the ease with which stones may be split, and for ornamental purposes contribute to aesthetic effects as much as color.

Physical Properties and Minimum ASTM Requirements											
Stone Type	Maximum Absorption by Weight, ASTM C97 (%)	Minimum Density, ASTM C97 (%)	Minimum Compressive Strength, ASTM C170 (psi)	Minimum Modulus of Rupture, ASTM C99 (psi)	Minimum Abrasion Resistance, ASTM C241 (hardness)	Minimum Flexural Strength, ASTM C680 (psi)	Maximum Acid Resistance, ASTM C217 (in.)	Thermal Expansion Coefficient (10 ⁻⁶ /°F)	Modulus of Elasticity (psi)	Ultimate Shear Strength (psi)	Ultimate Tensile Strength (psi)
Marble											
ASTM C503											
I. Calcite	0.20	162	7500	1000	10	1000	N/A	3.69–12.30	1,970,000 to 14,850,000	1638 to 4812	50 to 2300
II. Dolomite	0.20	175	7500	1000	10	1000	N/A				
III. Serpentine	0.20	168	7500	1000	10	1000	N/A				
IV. Travertine	0.20	144	7500	1000	10	1000	N/A				
Limestone											
ASTM C568											
I. Low Density	12.0	110	1800	400	10	—	N/A	2.4–3.0	3,300,000 to 5,400,000	900 to 1800	300 to 715
II. Medium Density	7.5	135	4000	500	10	—	N/A				
III. High Density	3.0	160	8000	1000	10	—	N/A				
Granite											
ASTM C615											
I. Low Density	0.40	160	19000	1500	—	—	N/A	6.3–9.0	5,700,000 to 8,200,000	2000 to 4800	600 to 1000
Quartz-based stone											
ASTM C616											
I. Sandstone	20.0	135	2000	300	8	—	N/A	5.0–12.0	1,900,000 to 7,700,000	300 to 3000	280 to 500
II. Quartzite Sandstone	3.0	150	10000	1000	8	—	N/A				
III. Quartzite (Bluestone)	1.0	160	20000	2000	8	—	N/A				
Slate											
ASTM C629											
I. Exterior	0.25	—	—	across grain 9000 along grain 7200	8	—	0.015	9.4–12.0	9,800,000 to 18,000,000	2000 to 3600	3000 to 4300
II. Interior	0.45	—	—	—	8	—	0.025				

Figure 5-1 Properties of building stone.

Durability of stone, or its resistance to wear and weathering, is also considered roughly analogous to silica content. This is perhaps the most important characteristic of stone because it affects the life span of a structure. The stones traditionally selected for building construction have exhibited almost immeasurable durability compared to other building materials.

5.3 PRODUCTION

Stone is quarried from its natural bed by various techniques, depending on the nature of the rock. The most basic, and the oldest, method is drilling and splitting. With stratified material such as sandstone and limestone, the process is facilitated by natural cleavage planes, but also limited in the thickness of stone that can be produced. Holes are drilled close together along the face of the rock, and plugs and wedges are then driven in with sufficient pressure to split the rock between holes. For stratified rock, holes are drilled only on the face perpendicular to the bed, but non-stratified material must be drilled both vertically and horizontally. Channeling machines are often used on sandstone, limestone, and marble, but cannot be used with granite or other very hard stone. Wire saws are now used by most stone producers to cut a smoother surface, reduce the required mill finishing, and to subdivide large blocks of stone for easier transport, handling, and finishing.

The first stones cut from the quarry are large, with rough, irregular faces (see Fig. 5-2). These monolithic pieces are cut or split to the required rough size, then dressed at the mill with power saws and/or hand tools. Finished stone surface textures may vary from a rough rock face to a more refined hand-tooled or machine-tooled finish. For thin facings of marble or granite, gang saws cut several slabs from a block of stone at the same time. Although the sawing is a slow process, the surface it produces is so even that much work is saved in later dressing and polishing. Other saws, such as chat saws, shot saws, and diamond saws, are used to cut rough blocks of stone to required dimensions. Each type of saw produces a different surface texture.

In the 1970s the Italian stone industry developed new technology that enabled it to produce thin sliced marble and granite panels that were light enough to clad high-rise buildings and inexpensive enough to dress the lobbies of speculative office buildings. Diamond-studded cables were devised to cut large blocks of stone from the quarry with little waste, and large diamond-tipped blades were ganged together to cut the slabs into $\frac{1}{8}$ -, $1\frac{1}{4}$ -, and $1\frac{1}{2}$ -in. thicknesses. Ultra-thin marble and granite tiles could also be cut in $\frac{1}{8}$ - and $\frac{3}{16}$ -in. thicknesses and then gang-ground and polished with large multi-headed machines. While the cost of other cladding materials went up, the price of stone came down because of this new capability of producing more surface for less cost. Between 1980 and 1985, the use of travertine in the United States increased 600%, marble 625%, and granite an astonishing 1735%.

For exterior use, a minimum thickness of 2 in. is usually necessary. The use of veneers less than 2 in. thick is still relatively new compared to the long history of stone masonry, and much is still being learned about their in-service behavior and long-term performance. Thinner stone veneers typically are more problematic.

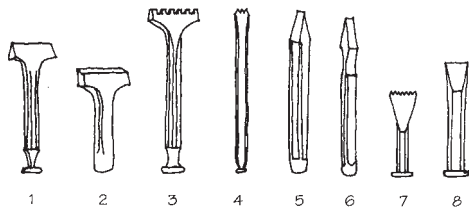
In addition to sawed finishes, stone may also be dressed with hand or machine tools. Planing machines prepare a surface for hammered finishes, for polished finishes, and for honed or rubbed finishes. A carborundum machine, used in place of a planer, will produce a very smooth finish. Honing is accomplished by rubbing the stone surface with an abrasive such as silicon carbide or sand after it has been planed, while a water spray is used to control



Figure 5-2 Quarrying stone. (Photo courtesy Georgia Marble Co.)

dust. Larger surfaces are done by machine, smaller surfaces and moldings by hand. Polished surfaces require repeated rubbing with increasingly finer abrasives until the final stage, which is done with felt and a fine polishing material. Only granite, marble, and some very dense limestones will take and hold a high polish. Power-driven lathes have been developed for turning columns, balusters, and other members that are round in section.

Hand tooling is the oldest method of stone dressing. Working with pick, hammer, and chisels (see Fig. 5-3), the mason dresses each successive face of the stone, giving it the desired finish and texture. The drawings in Fig. 5-4 illustrate the various steps in dressing the face, beds, and joints of a rough stone. Other hand-applied finishes include the bush-hammered, patent-hammered, pick-pointed, crandalled, and peen-hammered surface (see Fig. 5-5). Many of these finishes are now applied with pneumatic rather than hand tools, resulting in a more uniform surface. Ornate carving is still done by hand,



1. 2-3" wide drove chisel
2. 3-1/2"—4-1/2" wide boaster or bolster tool
3. 19th century tooth chisel
4. 16th century Italian tooth chisel
5. 19th century narrow chisel
6. splitting chisel
7. 1-3/4" 7-tooth chisel
8. 1-1/2" chisel

Figure 5-3 Traditional stone chisels. (From Harley J. McKee, Introduction to Early American Masonry, National Trust for Historic Preservation and Columbia University, Preservation Press, Washington, D.C., 1973.)

both for new construction and for restoration and rehabilitation projects, although it is sometimes aided by pneumatic chisels.

Another finishing technique that produces a roughened surface is called flame cutting, or thermal finishing. A natural gas or oxyacetylene flame is passed over a polished surface that has been wetted. The water that has been absorbed by the stone changes to steam and breaks off the surface, leaving an irregular finish. This finish can be selectively applied to portions of a stone surface to provide contrast.

A polished finish, by providing some measure of sealing of the stone pores, helps protect the surface of the veneer from deterioration by atmospheric weathering agents. A thermal finish, frequently used on granite, reduces the effective thickness by about $\frac{1}{8}$ in. Bush-hammered and other similar surface finishes also reduce the effective thickness.

In addition to geologic origin and mineral composition, stone can be identified by the form in which it is used. Stone is used for masonry construction in many forms and is available commercially as (1) rubble stone, (2) flagstone, (3) dimension stone, (4) thin veneers, and (5) tile. Stone rubble is irregular in size and shape. *Fieldstone rubble* is harvested from fields in its natural form. It is weathered smooth, but irregular and uneven (see Fig. 5-6). *Quarried rubble* comes from the fragments of stone left over from the cutting and removal of large slabs at the stone quarry. It has freshly broken faces, which may be sharp and angular. Rubble may be either broken into suitable sizes or roughly cut to size with a hammer. Some common types of stonework are shown in Fig. 5-7. *Flagstone* consists of thin slabs from $\frac{1}{2}$ to 2 in. thick in either squared or irregular shapes. It may be quarried material that has been cut into flat slabs, a field stone that is naturally flat enough for paving, or a stone that naturally splits into thin layers. Surfaces may be slightly

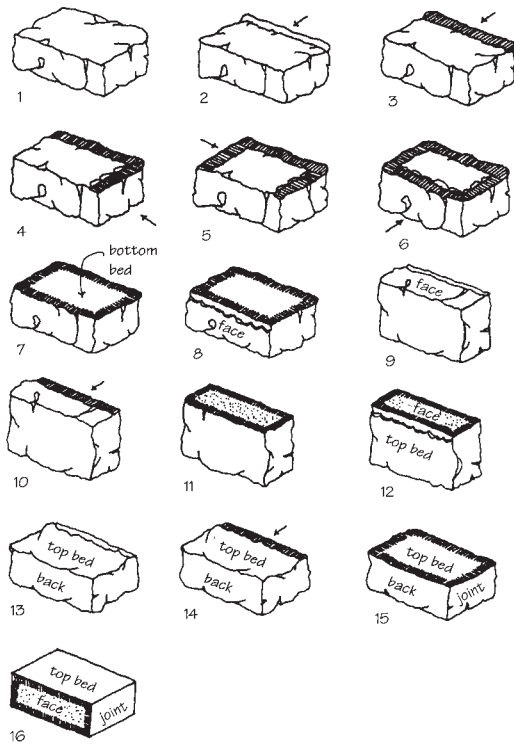


Figure 5-4 Steps in hand dressing the face, beds, and joints of a rough stone. (From Harley J. McKee, *Introduction to Early American Masonry*, National Trust for Historic Preservation and Columbia University, Preservation Press, Washington, D.C., 1973.)

rough, smooth, or polished. Flagstone is used on the exterior for walks, paths, and terraces, and on the interior as stair treads, flooring, coping, sills, and so on. *Dimension stone*, such as ashlar, decorative elements, and thin veneer slabs, is delivered from stone fabricators cut and dressed to a specific size and thickness and squared to dimension each way. Surface treatments include a rough or natural split face, smooth, slightly textured, or polished finishes. Ashlar is a type of flat-faced dimension stone, generally in small squares or rectangles, with sawed or dressed beds and joints. Dimension stone is used

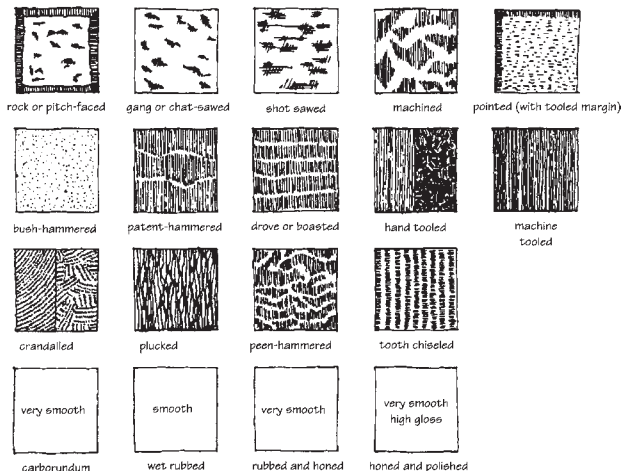


Figure 5-5 Stone surface finishes. (From Ramsey and Sleeper, *Architectural Graphic Standards*, 6th edition, ed. Joseph Boaz. Copyright 1970 by John Wiley & Sons, Inc. Reprinted by permission of John Wiley & Sons, Inc.)

for interior and exterior surface veneers, prefabricated panels, bearing walls, toilet partitions, arch stones, flooring, copings, stair treads, sills, and so on.

Thin stone veneers are a type of dimension stone, cut to a thickness of 2 in. or less. Unlike conventionally set dimension stone, which is laid in mortar and mechanically anchored to a backing system at the project site, thin stone may be anchored directly to precast concrete panels, to glass-fiber-reinforced concrete (GFRC) panels, or to prefabricated steel truss panels. Thin stone may also be incorporated into stick-built or unitized metal curtainwall systems. *Stone tile* is generally limited to interior surfaces as wall and floor finish systems.

5.4 BUILDING STONE

Some of the natural stones that satisfy the requirements of building construction are granite, limestone, sandstone, slate, and marble (see Fig. 5-1). Many others, such as quartzite and serpentine, are used locally or regionally, but to a much lesser extent.

5.4.1 Granite

Granite has been used as a building material almost since the inception of man-made structures. Because of its hardness, it was first used with exposed, hand-split faces. As tools and implements were improved, the shapes

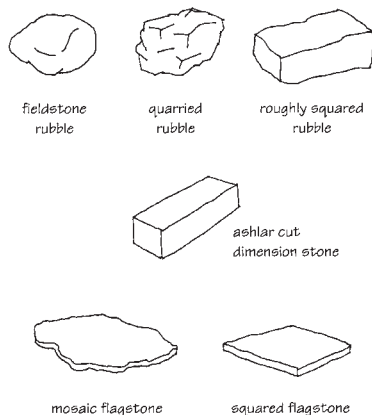
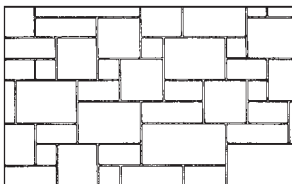


Figure 5-6 Building stone is used in several forms.

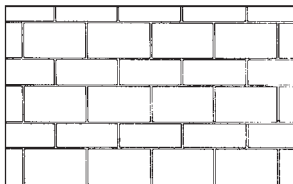
of the stone became more sophisticated. With the development of modern technology and improved methods of sawing, finishing, and polishing, granite was more readily available in the construction market and more competitive with the cost of other, softer stones.

Granite is an igneous rock composed primarily of quartz, feldspar, mica, and hornblende. Colors vary depending on the amount and type of secondary minerals. Feldspar produces red, pink, brown, buff, gray, and cream colors, while hornblende and mica produce dark green or black. Granite is classified as fine, medium, or coarse grained. It is very hard, strong, and durable, and is noted for its hard-wearing qualities. Compressive strength may range from 7700 to 60,000 psi, but ASTM C615, *Standard Specification for Granite Dimension Stone*, requires a minimum of 19,000 psi for acceptable performance in building construction (see Fig. 5-1). While the hardness of the stone lends itself to a highly polished surface, it also makes sawing and cutting very difficult. Granite is often used for flooring, paneling, veneer, column facings, stair treads, and flagstones, and in landscape applications. Carving or lettering on granite, which was formerly done by hand or pneumatic tools, is now done by sandblasting, and can achieve a high degree of precision.

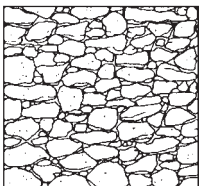
For granite, the National Building Granite Quarries Association recommends a maximum variation in the dimensions of any individual piece of stone of one-quarter of the specified bed and joint width. Variations from true plane or flat surfaces on polished, honed, and fine-rubbed finishes at the bed and joint arris lines may not exceed $\frac{3}{16}$ in. or one-sixth of the specified joint width, whichever is greater. For other types of finishes, the maximum variation cannot exceed one-quarter of the specified joint width. Variations from true plane on other parts of the face surface are based on the type of finish (see Fig. 5-8).



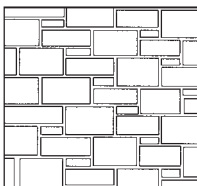
random ashlar



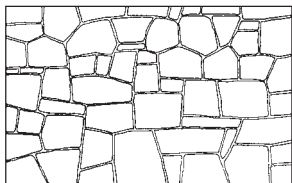
ashlar range



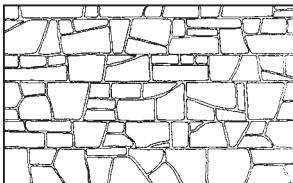
uncoursed fieldstone rubble



random coursed ashlar



random mosaic rubble



coursed rubble

Figure 5-7 Stone bonding patterns. (From Ramsey and Sleeper, *Architectural Graphic Standards*, 6th edition, ed., 1970. Reprinted by permission of John Wiley & Sons, Inc., and Allen, *Fundamentals of Building Construction*, 3rd ed., 1999.)

5.4.2 Limestone

Limestone is a sedimentary rock which is durable, easily worked, and widely distributed throughout the earth's crust. It consists chiefly of calcium carbonate deposited by chemical precipitation or by the accumulation of shells and other calcareous remnants of animals and plants. Very few limestones consist wholly of calcium carbonate. Many contain magnesium carbonates in varying proportions, sand or clay, carbonaceous matter, or iron oxides, which may color the stone. The most "pure" form is *crystalline* limestone, in which calcium

Variations from True Plane for Granite Building Stone	
Type of Finish	Variations From True Plane on Parts of Face Surfaces Other Than Bed and Joint Arris Lines (in.)
Polished, honed or fine rubbed	±3/64
Rubbed or fine stippled sand blasted	±1/16
Shot ground, 8- and 6- cut	±3/32
4-cut and sawn	±1/8
Thermal and coarse stippled sand blasted	±3/16

Figure 5-8 Fabrication tolerances for granite building stone. (From Specifications for Architectural Granite, *National Building Granite Quarries Association, Inc., West Chelmsford, MA, 1986.*)

carbonate crystals predominate, producing a fairly uniform white or light gray stone of smooth texture. It is highest in strength and lowest in absorption of the various types of limestone. *Dolomitic* limestone contains between 10 and 45% magnesium carbonate, is somewhat crystalline in form, and has a greater variety of texture. *Oolitic* limestone consists largely of small, spherical calcium carbonate grains cemented together with calcite from shells, shell fragments, and the skeletons of other marine organisms. It is distinctly non-crystalline in character, has no cleavage planes, and is very uniform in composition and structure.

The compressive strength of limestone varies from 1800 to 28,000 psi, depending on the silica content, and the stone has approximately the same strength in all directions. ASTM C568, *Standard Specification for Limestone Dimension Stone*, classifies limestone in three categories: I (low density), II (medium density), and III (high density), with minimum required compressive strengths of 1800, 4000, and 8000 psi, respectively. Limestone is much softer, more porous, and has a higher absorption capacity than granite, but is a very attractive and widely used building stone. Although soft when first taken from the ground, limestone weathers hard upon exposure. Its durability is greatest in drier climates, as evidenced by the remains of Egyptian and Mayan monuments.

Impurities affect the color of limestone. Iron oxides produce reddish or yellowish tones while organic materials such as peat give a gray tint. Limestone textures are graded as A, statuary; B, select; C, standard; D, rustic; E, variegated; and F, old Gothic. Grades A, B, C, and D come in buff or gray, and vary in grain from fine to coarse. Grade E is a mixture of buff and gray, and is of unselected grain size. Grade F is a mixture of D and E and includes stone with seams and markings.

When quarried, limestone contains groundwater (commonly called quarry sap) that includes varying amounts of organic and chemical matter. Gray stone generally contains more natural moisture than buff-colored stone. As the quarry sap dries and stabilizes, the stone lightens in color and is said to "season." Buff stone does not normally require seasoning beyond the 60 to 90 days it takes to quarry, saw, and fabricate the material. Gray stone, however, may require seasoning for as long as 6 months. If unseasoned stone is placed in the wall, it may be very uneven in color for several months, or even as long

as a year. No specific action or cleaning procedure will notably improve the appearance during this period, nor can it reduce the seasoning time. Left alone to weather, the stone eventually attains its characteristic light neutral color. No water repellents or other surface treatments should be applied until after the stone is seasoned.

Limestone is used as cut stone for veneer, caps, lintels, copings, sills, and moldings, and as ashlar with either rough or finished faces. Naturally weathered or fractured fieldstone is often used as a rustic veneer on residential and low-rise commercial buildings. Veneer panels may be sliced in thicknesses ranging from 2 to 6 in. and face sizes from 3×5 ft to 5×14 ft. When the stone is set or laid with the grain running horizontally, it is said to be on its natural bed. When the grain is oriented vertically, it is said to be on edge. Fabrication tolerances for limestone are shown in *Fig. 5-9*.

Travertine is a porous limestone formed at the earth's surface through the evaporation of water from hot springs. It is characterized by small pockets or voids formed by trapped gases. This natural and unusual texturing presents an attractive decorative surface highly suited to facing materials and veneer slabs.

The denser varieties of limestone, including travertine, can be polished and for that reason are sometimes classed as marble in the trade. Indeed, the dividing line between limestone and marble is often difficult to determine.

5.4.3 Marble

Marble is a crystallized, metamorphosed form of noncrystalline limestone or dolomite. Its texture is naturally fine, permitting a highly polished surface. The great color range found in marbles is due to the presence of oxides of iron, silica, mica, graphite, serpentine, and carbonaceous matter in grains, streaks, or blotches throughout the stone. The crystalline structure of marble adds depth and luster to the colors as light penetrates a short distance and is reflected back to the surface by the deeper-lying crystals. Pure marbles are white, without the pigmentation caused by mineral oxides. Brecciated marbles are made up of angular and rounded fragments embedded in a colored paste or cementing medium.

Dimensional Tolerances for Indiana Limestone						
Type of Stone	Length (in.)	Height (in.)	Deviation From Flat Surface, Exposed Face (in.)	Critical Depth (in.)	Non-Critical Depth (in.)	Deviation From Square (in.)
Smooth machine finish	±1/16	±1/16	±1/16	±1/16	±1/2	±1/16
Diamond gang finish	±1/16	±1/16	±1/4	±1/8	±1/2	±1/16
Chat sawed finish	±1/16	±1/16	±1/4	±1/8	±1/2	±1/16
Shot sawed finish	±1/16	±1/16	±1/2	±1/4	±1/2	±1/16
Pre-assembled units	±1/8	±1/8	±1/8	±1/8	±1/2	±1/8
Panels over 50 sq.ft.	±1/8	±1/8	±1/8	±1/8	±1/2	±1/8

Note: Tolerances for deviation from flat surface, exposed face and dimension from square are measured within the length of a standard 4'-0" straightedge applied at any angle on the face of the stone.

Figure 5-9 Fabrication tolerances for Indiana limestone. (From *Indiana Limestone Handbook, 17th ed., Indiana Limestone Institute, Bedford, IN.*)

Marble often has compressive strengths as high as 20,000 psi, and when used in dry climates or in areas protected from precipitation, the stone is quite durable. Some varieties, however, are decomposed by weathering or exposure to industrial fumes, and are suitable only for interior work. ASTM C503, *Standard Specification for Marble Dimension Stone (Exterior)*, covers four marble classifications, each with a minimum required compressive strength of 7500 psi: I, calcite; II, dolomite; III, serpentine; and IV, travertine. Over 200 imported and domestic marbles are available in the United States. Each has properties and characteristics that make it suitable for different types of construction.

Marbles are classified as A, B, C, or D on the basis of working qualities, uniformity, flaws, and imperfections. For exterior applications, only group A, highest-quality materials should be used. The other groups are less durable, and will require maintenance and protection. Group B marbles have less favorable working properties than Group A, and will have occasional natural faults requiring limited repair. Group C marbles have uncertain variations in working qualities; contain flaws, voids, veins, and lines of separation; and will always require some repair (known as sticking, waxing, filling, and reinforcing). Group D marbles have an even higher proportion of natural structural variations requiring repair, and have great variation in working qualities.

Marble is available as rough or finished dimension stone and as thin veneer slabs for wall and column facings, flooring, partitions, and other decorative surface work. Veneer slabs may be cut in thicknesses from $\frac{3}{8}$ to 2 in. Light transmission and translucence diminish as thickness increases. Fabrication tolerances for marble are shown in Fig. 5-10.

5.4.4 Slate

Slate is also a metamorphic rock, formed from argillaceous sedimentary deposits of clay and shale. Slates containing large quantities of mica are stronger and more elastic than clay slates. The texture of slate is fine and compact with very minute crystallization. It is characterized by distinct cleavage planes permitting easy splitting of the stone mass into slabs $\frac{1}{2}$ in. or more in thickness. Used in this form, slate provides an extremely durable material for flooring, roofing, sills, stair treads, and facings. ASTM C629, *Standard Specification for Slate Dimension Stone*, requires that Type I exterior slate have a minimum modulus of rupture of 9000 psi across the grain and 7200 psi along the grain.

Allowable Tolerances for Marble Building Stone		
Thickness	Panel Finished on Both Faces (in.)	Panel Finished on One Face (in.)
Thin stock (3/4" to 2")	+0, -1/16	+1/8, -1/16
Cubic stock (over 2")	±1/16	+3/16, -1/8
Marble tile	—	±1/32
Sizes and Squareness		
Thin stock	±1/16	±1/16
Cubic stock	—	±1/16

Figure 5-10 Fabrication tolerances for marble building stone. (From Dimension Stone, Vol. III, *Marble Institute of America*.)

Small quantities of other mineral ingredients give color to the various slates. Carbonaceous materials or iron sulfides produce dark colors such as black, blue, and gray; iron oxide produces red and purple; and chlorite produces green tints. "Select" slate is uniform in color and more costly than "ribbon" slate, which contains stripes of darker colors.

5.4.5 Sandstone

Sandstone is a sedimentary rock formed of sand or quartz grains. Its hardness and durability depend primarily on the type of cementing agent present. If cemented with silica and hardened under pressure, the stone is light in color, strong, and durable. If the cementing medium is largely iron oxide, the stone is red or brown, and is softer and more easily cut. Lime and clay are less durable binders, subject to disintegration by natural weathering. Sandstone can be categorized by grain size and cementing media. Siliceous sandstone is cemented together with silica. It is resistant to sulfurous pollutants. Many siliceous sandstones contain iron, which is oxidized by acidic pollutants (or acidic cleaners), and turns the stone brown. Ferruginous sandstone is cemented together with iron oxide, so it is naturally red to deep brown in color. Calcareous sandstone is cemented together with calcium carbonate, which is sensitive to acids and can deteriorate rapidly in a polluted environment. Dolomitic sandstone is cemented together with dolomite, which is more resistant to acid. Argillaceous sandstone contains large amounts of clay, which can quickly deteriorate simply from exposure to rain.

ASTM C616, *Standard Specification for Quartz-Based Dimension Stone*, recognizes three classifications of stone. Type I, sandstone, is characterized by a minimum of 60% free silica content; Type II, quartzite sandstone, by 90% free silica; and Type III, quartzite, by 95% free silica content. As a reflection of these varying compositions, minimum compressive strengths are 2000, 10,000, and 20,000 psi, respectively. Absorption characteristics also differ significantly, ranging from 20% for Type I to 3% for Type II and 1% for Type III. When first taken from the ground, sandstone contains large quantities of water, which make it easy to cut. When the moisture evaporates, the stone becomes considerably harder.

Sandstones vary in color from buff, pink, and crimson to greenish brown, cream, and blue-gray. It is traces of minor ingredients such as feldspar or mica that produce the range of colors. Both fine and coarse textures are found, some of which are highly porous and therefore low in durability. The structure of sandstone lends itself to textured finishes, and to cutting and tooling for ashlar and dimension stone in veneers, moldings, sills, and copings. Sandstone is also used in rubble masonry as fieldstone. Flagstone or bluestone is a form of sandstone split into thin slabs for flagging.

5.5 SELECTING STONE

Stone for building construction is judged on the basis of (1) appearance, (2) durability, (3) strength, (4) economy, and (5) ease of maintenance. Design and aesthetics will determine the suitability of the color, texture, aging characteristics, and general qualities of the stone for the type of building under consideration. Colors may range from dull to brilliant hues, and from warm to cool tones. Textures may vary from coarse or rough to fine and dense (see *Figs. 5-11 and 5-12*). Limestones are generally considered in the broader range of commercial and institutional applications. Some stones, such as granite, will soften very slowly in tone and outline, and will retain a sharp edge and hard contour indefinitely. Others mellow in tone and outline,



Figure 5-11 Rubble stone veneers.

becoming softer in shape without losing their sense of strength and durability. Elaborately carved ornaments and lettered panels require stones of fine grain to produce and preserve the detail of the artist's design.

The compressive strength of stone was of great importance when large buildings were constructed of loadbearing stone walls and foundations. Today however, stone is more often used as a thin veneer over steel, concrete, or unit masonry structures, or as loadbearing elements only in low-rise structures. In these applications, the compressive loads are generally small, and nearly all of the commonly used building stones are of sufficient strength to maintain structural integrity.

In terms of practicality and long-term cost, durability is the most important consideration in selecting building stones. Suitability will depend not only on the characteristics of the stone, but also on local environmental and climatic conditions. Frost is the most active agent in the destruction of stone. In warm, dry climates, almost any stone may be used with good results. Stones of the same general type such as limestone, sandstone, and marble differ greatly in durability, depending on softness and porosity. Soft, porous stones are more liable to absorb water and to flake or disintegrate in heavy frosts, and may not be suitable in the colder and more moist northern climates.



Figure 5-12 Stone veneer slabs.

Weathering of stone is the combined chemical decomposition and physical disintegration of the material. The thinner the stone is cut, the more susceptible it is to weathering. Marble naturally has a lower fatigue endurance than other stones, and there are a number of variables that affect its strength and stiffness. Certain environmental conditions will weaken marble over time, causing panels to fracture, crumble, or bow.

Most stone used for exterior building construction is relatively volume-stable, returning to its original dimensions after undergoing thermal expansion and contraction through a range of temperatures. Some fine-grained, uniformly textured, relatively pure marbles, however, retain small incremental volume increases after each heating cycle. Marble is actually composed of layers of crystals, and repeated thermal and moisture cycles tend to make these crystals loosen and slide apart. The marble becomes less dense when it expands during heating, but does not return to its prior state during the cooling cycle. This irreversible expansion is called *hysteresis*. In relatively thick veneers, the greater expansion on the exposed exterior surface is restrained or accommodated by the unaffected interior mass. In thin veneers, however, dilation of the surface region can easily overcome the restraint of the inner layers, causing a dishing effect because the greatest expansion is across the diagonal axis.

Expansion of the exterior face of marble panels increases the porosity of the stone and its vulnerability to attack by atmospheric acids and cyclic freezing. Thermal finishes, in addition to reducing the effective thickness of marble and granite panels, also cause micro-fracturing of the stone. The microcracks, in turn, permit moisture absorption to depths of at least $\frac{1}{8}$ in., which can result in physical degradation if the stone freezes while it is saturated.

Some soft marbles can be easily “granulated,” even by light impact forces such as pelting wind and rain. In addition to environmental problems, marble may bow naturally after it is quarried, and the thinner it is cut, the greater the tendency. Each time the thickness of marble is halved, the stresses are quadrupled. Marble can be a very non-uniform and unpredictable material, and preconstruction testing is critical to assure adequate performance.

Limestone and marble are both vulnerable to attack by sulfurous and sulfuric acids, and to a lesser extent, by carbonic acid and ammonium salts. Rainwater is a weak carbonic acid that dissolves the calcite or lime component, causing stones to flake, crumble, and eventually disintegrate. Sulfur-based acids form gypsum which is eventually washed from the stone matrix. Urban environments which produce stronger acid rain also produce accelerated disintegration. Chloride ions, such as those derived from de-icing salts like sodium chloride or calcium chloride, do not chemically react directly with stone. However, chloride can cause physical distress from the forces of crystal growth caused by calcium chloride salts precipitating from solutions within the stone, and by osmotic forces created by cyclic wetting. Porosity/permeability relationships and macro- and micro-fracturing influence these types of chemical weathering. Permeability is of increased significance in thin veneers. It is likely that water will penetrate thin stone veneers in greater amounts and at faster rates than would normally be expected.

Polished marble is not recommended for commercial floors. Polished finishes wear off rapidly, becoming dull and showing traffic patterns. Honed finishes are less slippery, require less maintenance, and look better with wear, becoming more polished from normal foot traffic. Granite is normally a better choice for floors. Porous stones require commercial sealers to protect them from stains. Food, grease, and sugared drinks readily penetrate porous stone faces, leaving unsightly stains that are difficult, if not impossible, to remove. Sealers not only protect these floors, but also enhance their natural colors.

Abrasion resistance of the stone must also be considered. If two or more varieties of stone are used, the abrasion resistance should be approximately the same, or uneven wear will result. Only stones highly resistant to wear should be used on stair treads.

Polished marble is also a very poor choice for bar and table tops. Acidic fruit juices, sugared drinks, and cola products can etch polished marble finishes, leaving spots and rings. Honed marble makes good bar and table tops, but polished granite is virtually impervious to damage from drink and food spills.

The costs of various stones will depend on the proximity of the quarry to the building site, the abundance of the material, and its workability. In general, stone from a local source will be less expensive than stone that must be imported; stone produced on a large scale will be less expensive than scarce varieties; and stone quarried and dressed with ease will be less expensive than stone requiring excessive time and labor.

This page intentionally left blank.

6

MORTAR AND GROUT

Although mortar may account for as little as 7% of the volume of a masonry wall, it influences performance far more than the percentage indicates. Aesthetically, mortar adds color and texture to the masonry. Functionally, it binds the individual units together, seals against air and moisture penetration, and bonds with anchors, ties, and reinforcing to join the building components structurally. For engineered construction and loadbearing applications, mortar strength and performance are as critical as unit strength and workmanship.

6.1 MORTAR PROPERTIES

Although concrete, masonry mortar, and masonry grout share some common ingredients (see Fig. 6-1), these three materials are quite distinct from one another. The methods and materials used to produce strong, durable concrete do not apply to masonry mortar and grout. The most important physical property of concrete is compressive strength, but compressive strength is only one of several properties important to mortar and grout, such as bond strength and durability. These qualities are influenced by three distinct sets of properties, which interact to affect overall performance: (1) *properties of the plastic mortar*, including workability, water retention, initial flow, and flow after suction; (2) *properties of the hardened mortar*, including bond strength, durability, and extensibility, as well as compressive strength; and (3) *mortar/unit assembly properties*.

6.1.1 Workability

Workability significantly influences most other mortar characteristics. Workability is not precisely definable in quantitative terms because there are no definitive tests or standards for measurement. Workability is recognized as a complex rheological property including adhesion, cohesion, density, flowability, plasticity, and viscosity, which no single test method can measure. A “workable” mortar has a smooth, plastic consistency, is easily spread with a trowel, and readily adheres to vertical surfaces. Well-graded, smooth aggregates enhance workability, as do lime, air entrainment, and proper amounts of mixing water. The lime imparts plasticity and increases the water-carrying capacity of the mix. Air entrainment introduces minute bubbles which act as

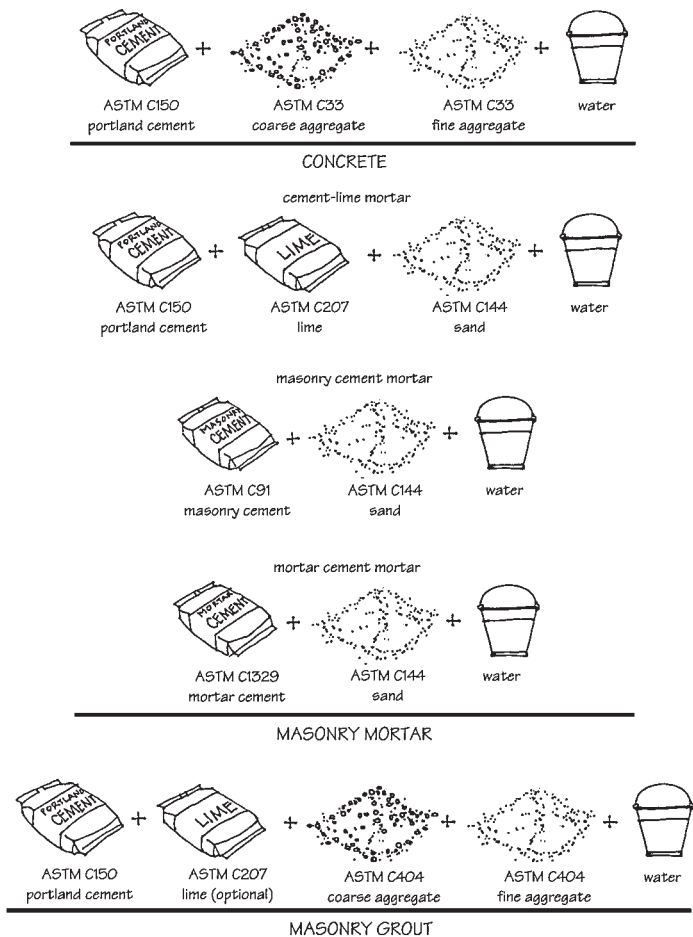


Figure 6-1 Comparison of ingredients used to make concrete, mortar, and grout. (From Beall and Jaffe, *Concrete and Masonry Databook*, McGraw-Hill, New York, 2003.)

lubricants in promoting flow of the mortar particles, but maximum air content is limited in mortars to minimize the reduction of bond strength. When structural reinforcement is incorporated in the mortar, cement-lime mixes are limited to 12% air content, and masonry cement mixes to 18%. Unlike concrete, mortar requires a *maximum amount of water* for workability, and retempering to replace moisture lost to evaporation should be permitted.

Variations in unit materials and in environmental conditions affect optimum mortar consistency and workability. Mortar for heavier units must be more dense to prevent uneven settling after unit placement or excessive squeezing of mortar from the joints. Warmer summer temperatures require a softer, wetter mix to compensate for evaporation. Although workability is easily recognized by the mason, the difficulty in defining this property precludes a statement of minimum requirements in mortar specifications.

6.1.2 Water Retention and Flow

Other mortar characteristics that influence general performance, such as aggregate grading, water retention, and flow, can be accurately measured by laboratory tests and are included in ASTM Standards. *Water retention* allows mortar to resist the loss of mixing water by evaporation and the suction of dry masonry units (see Fig. 6-2) to maintain moisture for proper cement hydration. It is the mortar's ability to retain its plasticity so that the mason can carefully align and level the units without breaking the bond between mortar and unit.

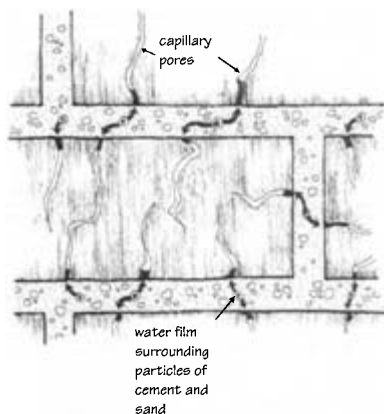


Figure 6-2 Exaggerated section showing capillary suction of water from mortar mix by dry masonry units. (Courtesy Acme Brick Company, Fort Worth, TX.)

Highly absorptive clay units may be prewetted at the job site, but concrete products may not be moistened, thus requiring that the mortar itself resist water loss. Conversely, if low-absorption units are used with a highly retentive mortar, they may “float.” Less retentive mortars may also “bleed” moisture, creating a thin layer of water between mortar and unit which can substantially reduce bond strength. Water retention generally increases as the proportion of lime in the mix increases (see Fig. 6-3). At one extreme, a mortar made with only portland cement and sand, without any lime, would have a high compressive strength but low water retention. At the other extreme, a mortar made with only lime and sand, without portland cement, would have low compressive strength but high water retention. High-suction units, especially if laid in hot or dry weather, should be used with a mortar that has high water retention (i.e., a higher proportion of lime). Low-suction units, especially if laid in cold or wet weather, should be used with a mortar that has low water retention (i.e., a lower proportion of lime). ASTM C91, *Standard Specification for Masonry Cements*, includes a water-retention test which simulates the action of absorptive masonry units, and mortar cements are tested for water retention in accordance with ASTM C1506, *Standard Test Method for Water Retention of Hydraulic Cement-Based Mortars and Plasters*.

Under laboratory conditions, water retention is measured by flow tests, and is expressed as the percentage of flow after suction to initial flow. The flow test is similar to a concrete slump test, but is performed on a “flow table” that is rapidly vibrated up and down for several seconds. Suction is

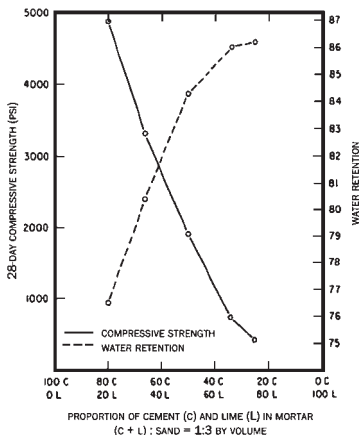


Figure 6-3 As more lime is substituted for portland cement in mortar, water retention increases and compressive strength decreases. (From Ritchie and Davison, *Cement-Lime Mortars*, National Research Council, Ottawa, Ont., Canada, 1964.)

applied by vacuum pressure to simulate the absorption of the masonry units, and the mortar is tested a second time on the flow table.

Although they accurately predict the water-retention characteristics of mortar, laboratory values differ significantly from field requirements. Construction mortars need initial flow values of the order of 130 to 150%, while laboratory mortars are required to have an initial flow of only 105 to 115%. The amount of mixing water required to produce good workability, proper flow, and water retention is quickly and accurately adjusted by experienced masons. Results produced from masonry assemblages prepared in the field reliably duplicate the standards set by laboratory researchers. Dry mixes lose too much water to the masonry units and will not cure properly. Excessively wet mixes cause units to float, and will decrease bond strength. The “proper” amount of mixing water is universally agreed upon as the maximum compatible with “workability,” and workability is best judged by the mason. Project specifications should not dictate water/cement ratios for masonry mortar or grout.

Mortar is subject to water loss by evaporation, particularly on hot, dry days. *Retempering* (the addition of mixing water to compensate for evaporation) is acceptable practice in masonry construction. Since highest bond strengths are obtained with moist mixes having good flow values, a partially dried and stiffened mortar is less effective if the evaporated water is not replaced. Mortar which has begun to harden as a result of cement hydration, however, should be discarded. Since it is difficult to determine by either sight or touch whether mortar stiffening is due to evaporation or hydration, it is customary to determine the suitability of mortar based on the time elapsed after initial mixing. Evaporative drying is related to both time and temperature. When ambient temperatures are above 80°F, mortar may be safely retempered as needed during the first 1½ to 2 hours after mixing. When temperatures are below 80°F, mortar may be retempered for 2½ to 3 hours after mixing before it should be discarded. ASTM C270, *Standard Specification for Mortar for Unit Masonry*, requires that all mortar be used within 2½ hours without reference to weather conditions, and permits retempering as frequently as needed within this time period. Tests have shown that the decrease in compressive strength is minimal if retempering occurs within recommended limits, and that it is much more beneficial to the performance of the masonry to maximize workability and bond by replacing evaporated moisture.

6.1.3 Bond Strength

For the majority of masonry construction, the single most important property of mortar is bond strength and integrity. For durability, weather resistance, and resistance to loads, it is critical that this bond be strong and complete. The term *mortar bond* refers to a property that includes

- Extent of bond or area of contact between unit and mortar
- Bond strength or adhesion of the mortar to the units

Bond strength can be tested as tensile bond or flexural bond. The mechanical bond between the mortar and the individual bricks, blocks, or stones unifies the assembly for integral structural performance, provides resistance to tensile and flexural stress, and resists the penetration of moisture. The strength and extent of the bond are affected by many variables of material and workmanship. Complete and intimate contact between the mortar and the unit is essential, and the mortar must have sufficient flow and workability to

spread easily and wet the contact surfaces. The masonry units must have surface irregularities to provide mechanical bond, and sufficient absorption to draw the wet mortar into these irregularities (see Fig. 6-4). The moisture content, absorption, pore structure, and surface characteristics of the units, the water retention of the mortar, and curing conditions such as temperature, relative humidity, and wind combine to influence the completeness and integrity of the mortar-to-unit bond. Voids at the mortar-to-unit interface offer little resistance to water infiltration and facilitate subsequent disintegration and failure if repeated freezing and thawing occur.

Investigations have shown that bond strength derives primarily from the mechanical interlocking of cement hydration crystals formed in the unit pores and on its surface. Higher bond strengths result if the extent of bond is good and the network of hydration products is complete. Although a certain amount of unit suction is desirable to increase the depth of penetration of the mortar paste, excessive suction reduces the amount of water available for hydration at the unit surface. *Moist curing* of masonry after construction assures complete hydration of the cement and improves mortar bond to high-suction brick and to dry, absorptive concrete masonry units (see Chapter 15). Clay brick with high initial rates of absorption (IRA) can leave the mortar without enough water for complete cement hydration. Clay brick with low IRA and non-absorptive units such as glass block provide little or no suction of the mortar paste into surface pores. These types of units require a relatively stiff, low-water-content mortar.

Unit texture also affects bond. Coarse concrete masonry units and the wire-cut surfaces of extruded clay brick produce a better mechanical bond than molded brick or the die-formed surfaces of extruded brick. Smooth glass block and smooth stone surfaces provide little or no mechanical bond with the mortar. Loose sand particles, dirt, coatings, and other contaminants also adversely affect mortar bond.

All other factors being equal, mortar bond strength increases slightly as compressive strength increases, although the relationship has no direct proportions. Mortar with a laboratory compressive strength of 2500 psi develops tensile bond strength of the order of 50 to 100 psi. Although higher cement ratios in the mix increase both compressive and bond strength, high cement-low lime mortars are stiff and do not readily penetrate porous unit surfaces. This leaves voids and gaps which disrupt the bond and decrease bond strength. Increasing air content, or adding air-entraining ingredients,

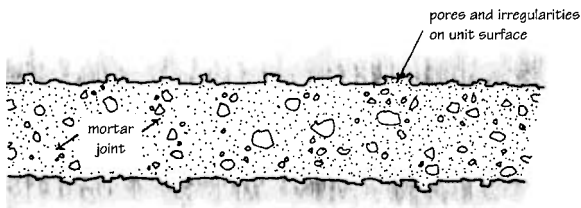


Figure 6-4 Exaggerated section showing increased mechanical bond between mortar and porous or rough unit surface.

lowers both compressive and bond strength, because the air voids decrease surface contact area and bearing area.

Workmanship is a critical factor in bonding. Full mortar joints must assure complete coverage of all contact surfaces, and maximum extent of bond is necessary to reduce water penetration. Once a unit has been placed and leveled, additional movement will break or seriously weaken the bond. Mortars with high water retention allow more time for placing units before evaporation or unit suction alters the plasticity and flow of the mortar. Laboratory tests show that tapping the unit to level increases bond strength 50 to 100% over hand pressure alone.

Because of the many variables involved, it is difficult to develop laboratory tests of bond strength that produce consistent results. In addition to the properties of the mortar, bond strength testing is highly sensitive to unit properties, fabrication procedures, curing environment, and testing technique. Flexural bond strength is presently measured by ASTM C952, *Standard Test Method for Bond Strength of Mortar to Masonry Units* (the crossed brick couplet test), ASTM E518, *Standard Test Method for Flexural Bond Strength of Masonry*, ASTM C1072, *Standard Test Method for Measurement of Masonry Flexural Bond Strength* (the bond wrench test), ASTM C1357, *Standard Test Methods for Evaluating Masonry Bond Strength*, and ASTM E72, *Standard Test Methods of Conducting Strength Tests of Panels for Building Construction* (full-scale wall specimen test). Full-scale wall specimen test results correlate well with the flexural bond strengths obtained using ASTM C1072 and E518. ASTM C1072 is the most widely used test.

A simple field test to check extent of bond can be made by lifting a unit from its fresh mortar bed to determine if the mortar has fully adhered to all bedding surfaces. Good extent of bond is indicated if the mortar sticks to the masonry unit and shows no air pockets or dry areas.

6.1.4 Compressive Strength

Masonry compressive strength depends on both the unit and the mortar. As with concrete, the strength of mortar is determined by the cement content and the water/cement ratio of the mix. Since water content is adjusted to achieve proper workability and flow, and since bond strength is ultimately of more importance, higher compressive values are sometimes sacrificed to increase or alter other characteristics. For loadbearing construction, building codes generally provide minimum allowable working stresses, and required compressive strengths may easily be calculated using accepted engineering methods. Strengths of standard mortar mixes may be as high as 5000 psi, but need not exceed either the requirements of the construction or the strength of the units themselves. Although compressive strength is less important than bond, simple and reliable testing procedures make it a widely accepted basis for comparing mortars. Basically, compressive strength increases with the proportion of cement in the mix and decreases as the lime content is maximized. Increases in air entrainment, sand, or mixing water beyond normal requirements also reduce compressive strength values.

For veneer construction and for two- and three-story loadbearing construction, mortar compressive strength is rarely a critical design factor because both the mortar and the masonry are usually much stronger in compression than necessary. Compressive strength is important in engineered, loadbearing construction, but structural failure due to compressive loading is rare. More critical properties such as flexural bond strength are usually given higher priority.

Although the compressive strength of masonry can be increased by using a stronger mortar, the improvement is not proportional. Tests indicate that wall strengths increase only about 10% when mortar strength increases 130%. There are incentives other than economy which dictate using mortar with only the minimum required compressive strength. An unnecessarily hard, brittle mortar may increase the amount of shrinkage cracking in the wall. A softer mortar with higher lime content is more flexible, permits greater movement, and gives more satisfactory performance as long as minimum requirements are met.

6.1.5 Extensibility and Volume Change

Two other important properties of hardened mortar are extensibility and volume change. *Volume changes* in mortar can result from the curing process, cycles of wetting and drying, temperature change, or unsound ingredients which expand chemically. Available data indicate that expansion and contraction of masonry construction due to differential thermal volume change between units and mortar do not have a noticeable effect on performance. However, total volume change from different causes can sometimes be significant. Stronger mortars that are rich in cement can show substantial shrinkage when exposed to alternate moist-dry conditions. Shrinkage during curing and hardening is greatest with high-water-content mortars. Volume changes caused by unsound ingredients such as reactive chemical compounds can cause disintegration of the masonry.

It is commonly believed that mortar shrinkage is significant, and that it is a primary cause of wall leaks. Research indicates, however, that maximum shrinkage across a mortar joint is minute, and is not in itself a cause of leakage. The most common leakage of masonry walls is through voids at the mortar-to-unit interface, where watertightness depends on a combination of good materials, workmanship, and design. The elastic properties of mortar, in fact, often counteract both temperature and moisture shrinkage.

Extensibility is defined as the amount per unit length that a specimen will elongate (creep), or the maximum unit tensile strain before rupture. Extensibility is sufficiently high in mortar so that when it is combined with the added plasticity which lime imparts to the hardened mix, slight movement can be accommodated without joints opening. For maximum resiliency (such as that required in chimney construction), mortar should be mixed with the highest lime content compatible with design requirements.

6.1.6 Durability

Durability is a measure of resistance to age and weathering, and particularly to repeated freeze-thaw cycles. Mortars with high compressive strength can be very durable, but a number of factors other than strength affect mortar durability. Ingredients, workmanship, volume change, elasticity, and the proper design and placement of expansion and control joints all influence durability and determine the maintenance characteristics of the construction. Although harsh environmental conditions and unsound ingredients can contribute to mortar deterioration, the most destructive factor is expansion of moisture in the wall by freezing. The bubbles introduced by air entrainment absorb the expansive forces of freezing water and provide good assurance against damage, but they also decrease both the compressive and bond strength of the mortar. Masonry cement mortars usually contain entrained air, and cement-lime mortars can be modified by using either air-entrained

portland cement or air-entrained hydrated lime (ASTM C207, Type SA). The best defense against freeze-thaw destruction is the elimination of moisture leaks at the joints with high-quality mortar ingredients and good bond, and the use of details which permit differential movement and provide adequate protection at the top of the wall and at penetrations.

Air-entrained cements are used in the concrete industry to provide resistance to freeze-thaw deterioration in horizontal applications where exposure to ponded water, ice, and snow is greatest. Entrained air produces voids in the concrete into which freezing water can expand without causing damage. Rigid masonry paving applications installed with mortared joints may also enjoy some of the benefits of air-entrained cements in resisting the expansion of freezing water. Although industry standards for masonry mortar generally limit the air content of mortar to 12, 14, or 18% depending on the mix, the benefits of higher air contents in resisting freeze-thaw damage in paving applications may be greater than the detrimental effects on bond strength. Rigid masonry paving systems are generally supported on concrete slabs, so the flexural strength of the masonry is less important than its resistance to weathering. Lower bond strength could probably be tolerated in such applications in return for increased durability.

6.1.7 Efflorescence and Calcium Carbonate Stains

Efflorescence is the white powdery deposit on exposed masonry surfaces caused by the leaching of soluble salts. If the units and the mortar ingredients contain no soluble salts such as sodium or potassium sulfate, and if insufficient moisture is present to effect leaching, efflorescence cannot occur. To minimize the possible contribution of mortar ingredients to efflorescence, specify portland cements with low alkali content, clean washed sand, and clean mixing water.

Unlike efflorescence, *calcium carbonate stains* are hard encrustations which can be removed only with acid cleaners. Calcium hydroxide is present in masonry mortar as part of the hydrated lime in cement-lime mortars, and as a by-product of the portland cement hydration process itself. Portland cement will produce about 12 to 20% of its weight in calcium hydroxide at complete hydration. Calcium hydroxide is only slightly soluble in water, but when large quantities of water enter the wall through construction defects, extended saturation of the mortar (1) prolongs the hydration process producing a maximum amount of calcium hydroxide, and (2) provides sufficient moisture to leach the calcium hydroxide to the surface. When it reacts with carbon dioxide in the air, the calcium hydroxide forms a concentrated calcium carbonate buildup, usually appearing as white streaks from the mortar joints. The existence of calcium hydroxide in cement-based mortar systems cannot be avoided. Preventing saturation of the wall both during and after construction, however, will eliminate the mechanism needed to form the liquid solution and carry it to the masonry surface.

6.2 MORTAR CLASSIFICATION

Egyptian builders of the twenty-seventh century B.C. first invented masonry mortar, when a mixture of burned gypsum and sand was used in the construction of the Great Pyramid at Giza. Greek and Roman builders later added or substituted lime or crushed volcanic materials, but it was not until the nineteenth-century development of portland cement that mortar became a high-strength structural component with compressive values comparable to the masonry units it bonded together.

6.2.1 Clay Mortars

Clay is one of the oldest materials used in masonry mortar. It has been used historically with sun-dried brick, burned brick, and stone. In North America, clay mortar was often used because of its low cost, but it was also a substitute in some regions where lime was difficult to obtain. Although it is susceptible to deterioration from moisture, clay mortar has long been used in arid climates, and also in humid climates for interior work and for exterior work which can be protected from the rain. Interior chimneys were commonly constructed with clay mortar up to the roof line, and one nineteenth-century specification permitted stone walls to be laid with clay mortar except for the outside 3 in. of walls above ground, and the inside 3 in. of cellar walls, which were to be pointed with lime mortar.

Ground fire clay is still used in mortars where a mild refractory quality is desired. Clay is also used as a proprietary plasticizer for mortar, and the Romans used ground clay from low-fired brick to impart pozzolanic properties to lime-sand mortars.

6.2.2 Lime-Sand Mortars

Mortars consisting of lime, sand, and water were the most common type used until the late nineteenth century. *Lime-sand mortars* have low compressive strength and slow setting characteristics, but offer good workability, high water retention, excellent bond, and long-term durability even in severe climates.

Lime-sand mortars cure and develop strength through a process called *carbonation*. The lime (calcium hydroxide) must combine with carbon dioxide in the air, so curing of the full joint depth occurs very slowly, over a period of months or years, and at variable rates. In the past, slower methods of construction could accommodate this gradual hardening, but modern building techniques and faster-paced production have virtually eliminated the use of lime-sand mortars except in historic restoration projects. Lime-sand mortars, however, were sufficiently flexible to accommodate slight movements caused by the uneven settlement of foundations, walls, piers, and arches. The slow curing permitted a gradual adjustment over long periods of time, and accounts for the greater elasticity of historical masonry compared to contemporary construction.

Hydraulic limes, made from limestone with clay impurities, require less water in slaking and less sand in mortar than pure lime. Hydraulic lime mortars were used extensively in civil construction during the nineteenth century, and particularly in the construction of canals, piers, and bridges. The distinction between hydraulic lime and “natural cement” is almost arbitrary. One natural cement product manufactured in the early nineteenth century, in fact, was called “artificial hydraulic lime.” Natural cement rock was burned in kilns similar to those used for producing lime, and the calcined lumps were ground into a fine powder in various patented processes.

Hydraulic lime or natural cement mortars were used in areas where greater strength was required and where the masonry was subject to continuous soil or moisture exposure. Volume shrinkage is high and workability often poor, so natural cement was sometimes used simply as an additive to lime-sand mortars to increase compressive strength.

6.2.3 Portland Cement-Lime Mortars

Since the latter part of the nineteenth century, portland cement has largely replaced hydraulic limes and natural cements in masonry mortars.

Occasionally, portland cement is used with sand and water only in what is called a *straight cement-sand mortar*. Mixed in proportions of 1 part cement to 3 parts sand, these mortars harden quickly and consistently, exhibit high compressive strengths, and offer good resistance to freeze-thaw cycles, but are stiff and unworkable, and have low water retention and poor bond.

Portland cement, which proved to be more stable and consistent in quality than natural cement, was first used as an additive in lime-sand mortars to provide greater compressive strength and promote faster setting. As the speed of building construction increased and portland cement gained wider acceptance, the proportion was increased until it accounted for as much as 80% of the cementitious ingredients.

Cement-lime mortars represent a compromise in the attempt to take advantage of the desirable properties of both lime-sand and straight cement-sand mortars. Workability, water retentivity, and compressive strength can be varied over a wide range of values by varying the proportions of cement and lime in the mix. Improvements in one property, however, are usually gained only at the expense of another. As workability and water retentivity increase with higher lime content, for instance, compressive strength decreases. Cement-lime mortars have a high sand-carrying capacity and generally require relatively high water content, which is beneficial in satisfying the moisture demands of unit absorption and cement hydration. During cold-weather construction, however, cement-lime mortars may be more susceptible to early-age freezing because of this high moisture content. During hot-weather construction, in dry conditions, or when highly absorptive units are used, cement-lime mortars generally perform better as their lime content increases. Board life is also extended with high-lime mortars.

Scanning electron microscopy has shown that cement-lime mortars can produce tight mechanical bonds with a continuous structure of hydration products and a low incidence of micro-cracks at the mortar-to-unit interface (see Fig. 6-5). Small voids at the interface, whether caused by drying shrinkage of the cement or by water or air bubbles in the mix, are often filled as the masonry ages by carbonation of the lime in the mortar. This process, known as *autogenous healing*, occurs when carbon dioxide reacts with the calcium hydroxide of the lime to form calcium carbonate. It is the same process of carbonation by which lime-sand mortars cure.

Cement-sand mortars gain about 75% of their ultimate strength in 10 to 14 days. With cement-lime mortars, ultimate strength development takes much longer, so small initial building movements can often be absorbed without breaking the bond between mortar and unit. Even after full cure, the extensibility of cement-lime mortars provides some elasticity to accommodate limited thermal and moisture movement in the masonry without cracking. Lime-rich mixes accommodate such movements more readily than the stronger and more rigid cement-rich mixes.

6.2.4 Masonry Cement Mortars

Proprietary masonry cements are widely used and are popular with masons because of their convenience, consistency, and economy (refer to Chapter 2). The first masonry cements were mixtures of portland cement and lime, preblended and prebagged to simplify job-site mixing operations and to increase batch-to-batch consistency. Other plasticizers such as ground clay, limestone,

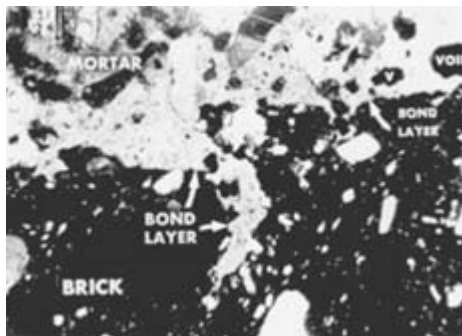


Figure 6-5 Microscopic view of mortar bond line. (Photos courtesy National Lime Association.)

and air-entrained cement were soon substituted for lime. Masonry cements generally contain one or more of the following materials:

- Portland cement or blended hydraulic cement
- A plasticizing material such as finely ground limestone, hydrated lime, or certain clays or shales
- Air-entraining agents
- Sometimes water-repelling agents

White and colored masonry cements containing mineral oxide pigments are available in many areas.

Air-entraining agents contribute to mortar workability by introducing millions of tiny air bubbles which act as lubricants in the mix. While the voids created by these bubbles usually reduce bond strength and increase water permeability, they also increase freeze-thaw durability by providing interstitial spaces which accommodate the expansion of ice crystals without damage to the structure of the mortar. To provide effective freeze-thaw resistance, the air content in masonry cement mortars ranges from 12% to 22%, compared to only 3% to 10% typically found in cast-in-place concrete mixes. ASTM standards limit the air content of masonry cement mortars which will contain structural reinforcement to a maximum of 18%. Air-entrained masonry cement mortars can provide a needed measure of protection against freeze-thaw deterioration in rigid masonry paving. The trade-off of reduced bond strength can usually be tolerated in paving applications because flexural stresses are carried by the supporting slab.

Masonry cement mortars generally require less mixing water to produce good workability than cement-lime mortars. The lower water content is advantageous during winter construction, and also reduces volume shrinkage and the potential for cracking in the wall. It also means that less water is available for cement hydration. In hot, dry weather and with highly absorptive units, loss of mixing water to evaporation or suction can be sufficient to stop the hydration process and impair the bond between unit and mortar. Such *dry-outs* can be avoided by moist curing the masonry, or by rehydrating the wall with a water fog spray (see Chapter 15).

Masonry cement mortars are less alkaline than cement-lime mortars. While this reduces the hazards of workers receiving burns to the skin, it also means the mortar will carbonate more rapidly. Carbonation is the process of chemical weathering in which the calcium hydroxide in hydrated portland cement reacts with atmospheric carbon dioxide to form calcium carbonate. Mortar that is carbonated is no longer alkaline, and no longer provides corrosion protection for embedded metal ties and reinforcing. Porosity affects the surface depth of carbonation. Porous mortars take carbon dioxide deeper into the joint to activate the process. Cracks or leaks in the construction will also increase carbonation, and water in sufficient quantity may contribute to calcium carbonate stains on the surface of the masonry.

6.2.5 "Mortar Cement" Mortars

A relatively new classification of masonry mortar is called *mortar cement mortars*. The physical requirements for mortar cement are covered in ASTM C1329, *Standard Specification for Mortar Cement* (see Fig. 6-6). Air content is limited based on the reduction in bond strength which it causes. Mortars with low flexural bond strength can crack under lateral loading, allowing water to penetrate and corrode reinforcing steel. Values for minimum flexural bond strength were established by testing cement-lime mortars and concrete brick (which develops lower bond strength than clay brick) in standard bond wrench tests, so ASTM C1329 also limits or excludes certain harmful or deleterious materials as mortar cement ingredients.

ASTM C1329 essentially sorts out masonry cements with high flexural bond strength capabilities from those which can only provide lower bond strengths. The mortar cements which meet ASTM C1329 are capable of producing mortars with flexural bond strengths equivalent to those of portland cement-lime mortars under identical laboratory test conditions. When high

Property	Physical Requirements		
	Masonry Cement Type		
	Type N	Type S	Type M
Fineness, residue on a No. 325 sieve (maximum %)	24	24	24
Autoclave expansion (maximum %)	1.0	1.0	1.0
Time of setting, Gillmore method (minutes)			
initial set not less than	120	90	90
final set not more than	1,440	1,440	1,440
Compressive strength (psi), average of 3 cubes, [‡] equal to or higher than the values specified for the ages indicated below:			
7 days	500	1,300	1,800
28 days	900	2,100	2,900
Flexural bond strength, 28 days, minimum (psi)	70	100	115
Air content of mortar, prepared and tested in accordance with requirements of ASTM C91			
minimum (% volume)	8	8	8
maximum (% volume)	16	14	14
Water retention value (minimum % of original flow)	70	70	70

[‡] Mortar cubes composed of 1 part cement and 3 parts blended sand (half graded standard sand and half standard 20-30 sand) by volume, prepared and tested in accordance with ASTM C91.

Figure 6-6 Minimum requirements for ASTM C1329 mortar cements and mortar cement mortars. (Copyright ASTM, 100 Barr Harbor Drive, West Conshohocken, PA 19428. Reprinted with permission.)

flexural bond strengths are required on a project and it is also desirable to use a masonry cement for its advantageous properties, a mortar cement conforming to ASTM C1329 should be specified.

6.2.6 The Portland-Lime Mortar versus Masonry Cement Mortar Controversy

For years there has been controversy over the relative merits of mortars made with portland cement and lime versus masonry cement. The preponderance of industry literature advocates the use of portland cement-lime mortars, and architects and engineers usually have a greater level of confidence in their performance. On the other hand, masons tend to prefer masonry cements because of their excellent workability, batch consistency, and easy mixing. In a survey conducted by *Aberdeen's Magazine of Masonry Construction* (February 1991, Vol. 4, No. 2), it was reported that the responding architects specified portland cement-lime mortars about 80% of the time on both commercial and residential projects. Responding masonry contractors indicated that they use masonry cement mortars nearly 70% of the time on residential projects and only about 50% of the time on commercial projects. For water leakage, bond strength, and durability, both the contractors and the architects preferred portland cement-lime mortars.

Historically, portland cement-lime mortars have exhibited higher flexural strengths than masonry cement mortars. Higher flexural strengths increase not only resistance to lateral wall loads, but resistance to moisture penetration as well. It is difficult to assess the scientific data objectively. Most laboratory

test studies that have been performed have usually been sponsored by either the lime industry or the masonry cement industry, and the studies can easily be designed to emphasize the strong points of either mortar. In Grimm's *Conventional Masonry Mortar: A Review of the Literature* (published by the University of Texas at Arlington's Construction Research Center), conflicting research reports are numerous. As with any proprietary product, there are high-quality masonry cements and poor-quality ones. The selection or acceptance of a particular brand of cement should be based on its performance history and on independent laboratory verification of conformance to ASTM standards.

Masonry cements are more widely used than portland cement-lime for masonry mortars, and the vast majority of projects which incorporate them perform quite satisfactorily. On projects which have experienced flexural bond failures or excessive moisture penetration, the culprit is seldom found to be attributable solely to the use of masonry cement versus portland cement and lime in the mortar. Usually, there are other defects which contribute more to the problems, such as poor workmanship, inadequate flashing details, or low-strength backing walls. Both portland cement-lime mortars and masonry cement mortars allow water penetration through masonry walls. The amount of water entering the wall is generally higher with masonry cement mortars, but when workmanship is poor, joints are unfilled, and flashing and weeps are not functional, either type of mortar can produce a leaky wall. There are no industry standards or guidelines identifying varying amounts of water penetration that are either acceptable or unacceptable. A wall system with well-designed and properly installed flashing and weeps will allow tolerance of a much greater volume of water penetration without damage to the wall, the building, or its contents than one without such safeguards. Ultimately, the workmanship and the flashing and weep-hole drainage system will determine the success or failure of most masonry installations (refer to Chapter 9).

Both masonry cement mortars and portland cement-lime mortars are capable of providing what the industry considers adequate flexural bond strength when they are designed and mixed in accordance with ASTM C270, *Standard Specification for Mortar for Unit Masonry*. If specific performance characteristics need to be enhanced for a particular application, laboratory design mixes should be based on unit/mortar compatibility and testing for the desired properties.

6.3 MORTAR TYPES

ASTM C270, *Standard Specification for Mortar for Unit Masonry*, outlines requirements for five different mortar types, designated as M, S, N, O, and K. Prior to 1954, mortar types were designated A-1, A-2, B, C, and D, but it was found that A-1 carried the connotation of "best" and that many designers consistently specified this type, thinking it was somehow better than the others for all applications. To dispel this misunderstanding, the new, arbitrary letter designations were assigned so that no single mortar type could inadvertently be perceived as best for all purposes. No single mortar type is universally suited to all applications. Variations in proportioning the mix will always enhance one or more properties at the expense of others.

6.3.1 Type M Mortar

Each of the five basic mortar types has certain applications to which it is particularly suited and for which it may be recommended. Type M, for instance, is a high-compressive-strength mix recommended for both reinforced and unreinforced masonry which may be subject to high compressive loads.

6.3.2 Type S Mortar

Type S mortar produces tensile bond values which approach the maximum obtainable with portland cement-lime mortar. It is recommended for structures subject to normal compressive loads but which require flexural bond strength for high lateral loads from soil pressures, high winds, or earthquakes. Type S should also be used where mortar adhesion is the sole bonding agent between facing and backing, such as the application of adhesion-type terra cotta veneer. Because of its excellent durability, Type S mortar is also recommended for structures at or below grade and in contact with the soil, such as foundations, retaining walls, pavements, sewers, and manholes.

6.3.3 Type N Mortar

Type N is a good general-purpose mortar for use in above-grade masonry. It is recommended for exterior masonry veneers and for interior and exterior load-bearing walls. This “medium-strength” mortar represents the best compromise among compressive and flexural strength, workability, and economy and is, in fact, recommended for most masonry applications.

6.3.4 Type O Mortar

Type O is a “high-lime,” low-compressive-strength mortar. It is recommended for interior and exterior non-loadbearing walls and veneers which will not be subject to freezing in the presence of moisture. Type O mortar is often used in one- and two-story residential work and is a favorite of masons because of its excellent workability and economical cost.

6.3.5 Type K Mortar

Type K mortar has a very low compressive strength and a correspondingly low tensile bond strength. It is seldom used in new construction, and is recommended in ASTM C270 only for tuckpointing historic buildings constructed originally with lime-sand mortar (refer to Chapter 15).

6.3.6 Choosing the Right Mortar Type

The Appendix to ASTM C270 contains non-mandatory guidelines on the selection and use of masonry mortars which are summarized in *Fig. 6-7*. To obtain optimum bond, use a mortar with properties compatible with those of the masonry units which will be used. To increase tensile bond in general:

- Increase the cement-to-lime ratio of the mortar within the limits established by ASTM C270.
- Keep air content within the limits established by ASTM C270.
- Use mortars with appropriate water retentivity for the absorption characteristics of the unit.
- Mix mortar with the maximum water content compatible with workability.
- Allow retempering of the mortar within recommended time limits.
- Use clay masonry units with moderate initial rates of absorption.
- Bond mortar to a rough surface rather than an extruded die skin.
- Minimize the time between spreading mortar and placing masonry units.
- Apply pressure in forming the mortar joint.

- Do not subsequently disturb units that have been placed.
- Moist-cure the masonry (refer to Chapter 15).

There are also several basic rules of thumb. Use mortar with the lowest compressive strength which meets structural requirements, because the lower the compressive strength, the more flexible the mortar in accommodating movements in the wall. In areas exposed to significant freeze-thaw cycling, and in particular for horizontal applications in those areas, specify mortars with a higher cement content or entrained air. For low-suction clay masonry units, use mortars with a lower lime content, and for high-suction clay masonry units, use mortars with a higher lime content.

For most projects, a Type N mortar is not only adequate in compressive and bond strength, it is the best choice for the compromise among various properties. On multi-story projects where higher wind loads at upper stories increase lateral loads, a Type S mortar will provide higher flexural bond strengths regardless of whether it is made from a masonry cement or from a

ASTM C270 Recommended Mortar Type Applications			
Location	Building Segment	Mortar Type	
		Recommended	Alternative
Exterior, above grade	Loadbearing walls	N	S or M
	Non-loadbearing walls	O [§]	N or S
	Parapet walls	N	S
Exterior, at or below grade	Foundation walls, retaining walls, manholes, sewers, pavements [†] , walks [†] and patios [†]	S	M or N
Interior	Loadbearing walls	N	S or M
	Non-loadbearing partitions	O [§]	N

[§] Type O mortar is recommended for use where the masonry is unlikely to be frozen when saturated and unlikely to be subjected to high winds or other significant lateral loads. Type N or S should be used in other cases.

[†] Masonry exposed to weather in a nominally horizontal surface is extremely vulnerable to weathering. Mortar for such masonry should be selected with due caution.

(Copyright ASTM, 100 Barr Harbor Drive, West Conshohocken PA, 19428. Reprinted with permission.)

RULE OF THUMB

Always select the mortar type with the lowest compressive strength appropriate to its location and use.

- Type N is most appropriate 95% of the time
- Type O mortar is most appropriate 80% of the time
- Type S is most appropriate 5% of the time
- Type M is most appropriate only 1% of the time.

(Statistics from Dr. John H. Matthys, Construction Research Center, University of Texas at Arlington.)

Figure 6-7 Mortar types and recommended applications.

portland cement and lime mix. The unnecessary specification of a Type S mortar when a Type N is adequate in strength sacrifices workability in the wet mortar and a degree of elasticity in the finished wall.

6.3.7 Proportion versus Property Method of Specifying Mortar

Conformance with ASTM C270 may be based either on volume proportions or on minimum property requirements (see Fig. 6-8). The *proportion specification*

Mortar Proportions (by Volume)										
Mortar	Type	Portland Cement or Blended Cement	Masonry Cement Type			Mortar Cement Type			Hydrated Lime or Lime Putty	Aggregate (Sand) Measured in a Damp, Loose Condition
			M	S	N	M	S	N		
Cement-Lime	M	1							¼ over ¼ to ½ over ½ to 1½ over 1¼ to 2½	not less than 2¼ and not more than 3 times the sum of the separate volumes of cement and lime
	S	1								
	N	1								
	O	1								
Mortar Cement	M	1				1		1		
	S	½					1	1		
	N							1		
	O							1		
Masonry Cement	M	1	1		1					
	S	½			1					
	N			1						
	O			1						

Mortar Properties [§] (ASTM C270 Test Methods)				
Mortar	Type	Minimum Average Compressive Strength at 28 Days (psi)	Minimum Water Retention (%)	Maximum Air Content (%)
Cement-Lime	M	2500	75	12
	S	1800	75	12
	N	750	75	14
	O	350	75	14
Mortar Cement	M	2500	75	12
	S	1800	75	12
	N	750	75	14
	O	350	75	14
Masonry Cement	M	2500	75	18
	S	1800	75	18
	N	750	75	20
	O	350	75	20

[§] The aggregate ratio, measured in a damp, loose condition, shall not be less than 2¼ and not more than 3 times the sum of the separate volumes of cement and lime.

[†] When structural reinforcement is incorporated in cement-lime or mortar cement mortars, maximum air content shall not exceed 12%. When structural reinforcement is incorporated in masonry cement mortars, maximum air content shall not exceed 18%.

Figure 6-8 Use either the proportion specification or property specification for mortar. (Copyright ASTM, 100 Barr Harbor Drive, West Conshohocken, PA 19428. Reprinted with permission.)

prescribes by volume the proportions of cementitious materials and aggregate for each mortar type. The *property specifications* are based on minimum compressive strength, minimum water retention, and maximum air content of laboratory-prepared samples made with a specified ratio of job-site sand.

The proportion requirements are conservative and, for cement-lime mortars, will generally yield compressive strengths higher than the minimums given in the property specification. Conversely, the minimum compressive strengths required by the property specification generally can be achieved with a smaller proportion of cement and lime than that prescribed under the proportion specification. The property specifications encourage preconstruction testing of sample mortar cubes for a mix design to gain the economic advantage of meeting strength requirements at lower cost. On larger projects, the savings in mortar costs will more than offset the cost of the laboratory testing. Since it is generally recommended to use the mortar type with the minimum necessary compressive strength, specifying mortar by the property requirement method assures that the mortar is not any stronger in compression than it needs to be. On smaller projects where the volume of mortar is much less, using the proportion specification saves the cost of laboratory mix designs and provides a high factor of safety in attaining adequate mortar strengths. However, it will usually yield mortars with higher compressive strengths than needed at the sacrifice of other properties.

If ASTM C270 is referenced in project specifications without indication as to whether the property or proportion method should be used, the proportion method always governs. The volume proportions used in ASTM C270 are based on weights per cubic foot of materials as listed in *Fig. 6-9*. The volume measurements for cement, lime, and sand are listed in *Fig. 6-10*. Mortar proportions may be calculated on full- and half-bag measures.

Material	Weight (lb/cu.ft.)
portland cement	94
hydrated lime	40
damp, loose sand	18.25

Figure 6-9 Weights of materials on which the proportion specification of ASTM C270 is based.

Material	Volume (cu.ft.)
1 bag portland cement	1.0
1 bag hydrated lime	1.0
1 ton wet sand	20.25
1 ton damp, loose sand	18.25
1 ton dry sand	16.25

Figure 6-10 Volume measurement of mortar materials.

The property specifications in ASTM C270 are for laboratory-prepared samples only, and the values will not correlate with those obtained from field samples tested under ASTM C780, *Standard Test Method for Preconstruction and Construction Evaluation of Mortars for Plain and Reinforced Unit Masonry*. Laboratory samples are made with a very low water-cement ratio, to simulate the moisture content of mortar after unit suction has occurred. Mortars mixed at the job site are made with much higher water-cement ratios because the units are absorptive and will immediately extract much of the mixing water from the mortar paste. Field-sampled mortars therefore typically yield a much lower compressive strength than laboratory-prepared mortar because of the difference in water content. In order to compare apples to apples, the same testing procedure must be used. If the project will require field sampling of mortar during construction for laboratory testing, ASTM C780 must be used both to set the preconstruction benchmark and to perform the construction phase testing. Results from ASTM C780 tests cannot be compared to results from ASTM C270 tests or to the minimum property requirements listed in ASTM C270. Because of the different water-cement ratios in the two test methods, the compressive strength values resulting from C780 field-sampled mortars are neither required nor expected to meet the minimum compressive strength requirements of C270, and they also do not represent the actual compressive strength of the mortar in the wall.

Until recently, there was no standardized test for hardened masonry mortar. ASTM C1324, *Standard Test Method for Examination and Analysis of Hardened Masonry Mortar*, now provides a standardized procedure for the petrographic and chemical analysis of hardened mortar samples to determine the proportions of ingredients used in the mix. The petrographic analysis is based on similar methods used to examine hardened concrete using a petrographic microscope and a stereoscopic low-power microscope, as well as X-ray diffractometry and scanning electron microscopy. The standard also includes methods for chemical analysis. The interpretation and calculation of chemical test results are dependent on results of the petrographic analysis and are not intended to be used alone. The chemical data and the petrographic analysis together are intended to determine mortar composition as represented by the proportion specifications in Table 1 of ASTM C270 as Types M, S, N, and O. Failure of a tested mortar specimen to comply with the proportion requirements of ASTM C270, however, does not necessarily mean that the mortar is not in compliance. Even though the proportions are different, the mortar may still meet the ASTM C270 property requirements. As yet, there is no standardized test to determine the compliance of hardened mortar samples with the property requirements of ASTM C270. Samples removed from a wall can be tested for compressive strength, but there is no correlation between these test results and the compressive strength requirements of ASTM C270.

6.4 SPECIALTY MORTARS

In determining the requirements for mortar performance, two very specialized areas demand detailed project analysis. Refractory mortars and chemical-resistant mortars are used primarily in industrial applications where exposure to extreme heat or toxic chemicals requires extraordinary mortar performance. Refractory mortars are also used in residential and commercial fireplaces.

6.4.1 Refractory Mortars

Refractory mortars may range from residential fireplace installations to extremely high-heat industrial boiler incinerators or steel pouring pits. Refractory mortars are made primarily from fire clay, with calcium aluminate or sodium silicate as a binder. Mortar joints for refractory mortars should not exceed $\frac{3}{4}$ in. The fire bricks are often dipped to get a thin mortar coating, with no conventional mortar bed laid. Exposure to heat in the firebox, smoke chamber, and flue ceramically fuses the mortar and seals the joints against heat penetration. For residential and commercial fireplaces, use a medium-duty mortar as determined by ASTM C199, *Pier Test for Refractory Mortar*. Manufacturers or suppliers should be consulted regarding design details and performance characteristics for special applications.

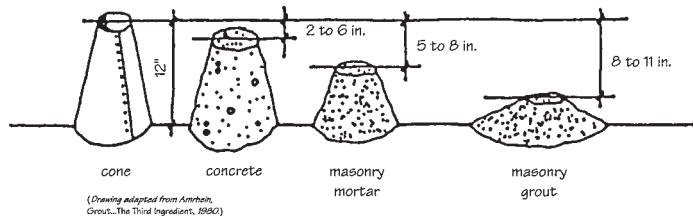
6.4.2 Chemical-Resistant Mortars

The field of chemical-resistant mortars is highly specialized and complex in nature. Durability depends very heavily on proper mortar selection. Even with the use of chemical-resistant brick or structural clay tile, mortar may still be attacked by acids or alkalis, causing joint disintegration and loosening of the masonry units. There are few chemicals which do not attack regular portland cement mortars. Consequently, it is necessary to develop chemical resistance by means of admixtures or surface treatments. Special cements or coatings are available which will withstand almost all service conditions, but different types react differently with various chemicals. The success of any particular treatment depends on local conditions, type and concentration of the chemical solution, temperatures, wear, vibration, type of subsurface, and workmanship. Joints should be as narrow as possible to minimize the exposed area and reduce the quantity of special material required. The selection of the optimum material for a particular installation must include the consideration of mechanical and physical properties as well as chemical-resistant characteristics.

Several special types are available, including sulfur mortars, silicate mortars, phenolic resin mortars, and furan, polyester, and epoxy resin mortars. The properties and capabilities may be altered by changing the formulations. For specific installations, full use should be made of available standards and test procedures, and the engineering advice, services, and recommendations of manufacturing specialists in this field should be solicited.

6.5 GROUT Grout is a fluid mixture of cementitious material and aggregate with enough water added to allow the mix to be poured or pumped into masonry cores and cavities without segregation (see Fig. 6-11). ASTM C476, *Standard Specification for Grout for Masonry*, covers both fine and coarse mixtures based on aggregate size and grading.

Selecting a fine or coarse grout is based on the size of the core or cavity as well as the height of the lift to be grouted. (Some building codes and standards have different requirements for the relationship of maximum aggregate size to clear opening, so for specific projects the governing code should always be checked.) In accordance with ASTM C404, *Standard Specification for Aggregates for Masonry Grout*, if the maximum aggregate size is $\frac{3}{4}$ in. or larger, the grout is classified as *coarse*. If the maximum aggregate size is less than $\frac{3}{4}$ in., it is classified as *fine*. The smaller the grout space, the smaller the maxi-



Concrete

Concrete is generally mixed with the *minimum* amount of water required to produce workability appropriate to the method of placement. The amount of water is determined by laboratory mix design.

Masonry Mortar

Masonry mortar is generally mixed with the *maximum* amount of water required to produce good workability with a given unit. The amount of water is determined by the mason based on masonry unit absorption and field conditions.

Masonry Grout

Masonry grout is usually mixed with the *maximum* amount of water required to produce good flow properties. The amount of water is determined by the mason based on masonry unit absorption and field conditions.

Figure 6-11 Relative consistency of concrete, mortar, and grout as measured by slump test.

imum aggregate size allowed. Although ASTM C404 limits the maximum aggregate size to $\frac{3}{8}$ in., some engineers allow up to $\frac{1}{2}$ -in. aggregate for grouting large voids such as columns and pilasters. The larger aggregate takes up more volume, reduces grout shrinkage, and requires less cement for equivalent strength. The table in Fig. 6-12 shows the recommended grout type for various grout spaces from the Masonry Standards Joint Committee (MSJC) *Specifications for Masonry Structures*.

Grout is an essential element of reinforced masonry construction. It must bond the masonry units and the steel together so that they perform integrally in resisting superimposed loads. In unreinforced loadbearing construction, unit cores are sometimes grouted to give added strength, and in non-loadbearing construction, to increase fire resistance. The fluid consistency of grout is important in determining compressive strength, in assuring that the mix will pour or pump easily and without segregation, and in assuring it will flow around reinforcing bars and into corners and recesses without voids. ASTM C476 specifies grout by volume proportions or by minimum strength. Optimum water content, consistency, and slump will depend on the absorption rate of the units as well as job-site temperature and humidity conditions. Performance records indicate that a minimum slump of 8 in. is necessary for units with low absorption, and as much as 10 in. for units with high absorption.

ASTM C476 permits specifying grout either by mix proportions (see Fig. 6-13) or by compressive strength. When the compressive strength method is

Minimum Grout Space Requirements for ASTM C476 Grout (with tolerance of +3/8" or -1/4")			
Grout Type	Maximum Grout Pour Height (ft.)	Minimum Width of Grout Space Between Wythes of Masonry [§] (in.)	Minimum Grout Space Dimensions for Grouting Cells or Cores of Hollow Units [†] (in. x in.)
Fine	1	¾	1½ x 2
Fine	5	2	2 x 3
Fine	12	2½	2½ x 3
Fine	24	3	3 x 3
Coarse	1	1½	1½ x 3
Coarse	5	2	2½ x 3
Coarse	12	2½	3 x 3
Coarse	24	3	3 x 4

§ Grout space dimension is the clear dimension between any masonry protrusion and shall be increased by the diameters of the horizontal bars within the cross section of the grout space.

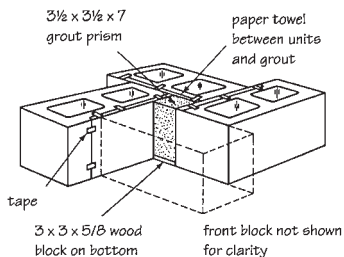
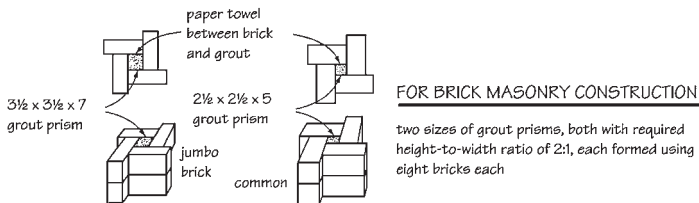
† Area of vertical reinforcement not to exceed 6% of the area of the grout space.

Figure 6-12 Minimum grout space requirements for fine or coarse grout. (From *Masonry Standards Joint Committee, Building Code Requirements for Masonry Structures, ACI 530/ASCE 5/TMS 402, American Concrete Institute, Detroit, MI, 1992.*)

- Specify masonry grout either by mix proportions or by minimum compressive strength.
- Select grout type based on the size of the space to be grouted.
- ASTM C476 and most building codes require a minimum grout compressive strength of 2000 psi when tested in accordance with ASTM C1019.

Grout Type	Parts by Volume of Portland Cement or Blended Cement	Parts by Volume of Hydrated Lime or Lime Putty	Aggregate Measured in Damp, Loose Condition	
			Fine	Coarse
Fine	1	0 to 1/10	2-1/4 to 3 times the sum of the volumes of the cement and lime	—
Coarse	1	0 to 1/10	2-1/4 to 3 times the sum of the volumes of the cement and lime	1 to 2 times the sum of the volumes of the cement and lime

Figure 6-13 Requirements for ASTM C476 masonry grout.



FOR CONCRETE MASONRY CONSTRUCTION

prism with required 2:1 height-to-width ratio
formed using four 8 x 8 x 16 concrete blocks

Figure 6-14 ASTM C1019 masonry grout test prisms.

used, the grout must be mixed to a slump of 8 to 11 in. Minimum 28-day compressive strength must be 2000 psi when tested in accordance with ASTM C1019, *Standard Test Method for Sampling and Testing Grout* (see Fig. 6-14). Actual compressive strength is usually higher because mixing water is absorbed by the units, reducing the water-cement ratio and increasing the strength. The water absorbed by the units is retained for a period of time, providing a moist condition for optimum curing of the grout. Unit absorption is affected not only by the characteristics of the brick or block, but also by the size of the cavity. The greater the surface area, the more water will be absorbed, so water content and slump limits should be adjusted accordingly.

7

MASONRY ACCESSORIES

Accessory items are important and integral components of masonry construction. Steel lintels, shelf angles, horizontal joint reinforcement, metal anchors, ties, fasteners, flashing materials, and other accessories must be of the highest quality to equal the quality of the masonry units themselves.

7.1 METALS AND CORROSION

Steel, which is most frequently used for fabrication of masonry accessories, requires protective coatings to isolate the metal from the corrosive effects of wet mortar. Several non-ferrous metals are also used for masonry accessories. *Copper* and copper alloys are essentially immune to the corrosive action of wet concrete and mortar. Because of this immunity, copper can be safely embedded in fresh mortar even under saturated conditions. Galvanic corrosion will occur, however, if copper and steel items are either connected or in close proximity to one another. The presence of soluble chlorides will also cause copper to corrode.

Aluminum is also attacked by fresh portland cement mortar and produces the same expansive pressures. Galvanic corrosion also occurs if aluminum and steel are embedded in the mortar in contact with one another. If aluminum is to be used in reinforced masonry, it should be electrically insulated by a permanent coating of bituminous paint, alkali-resistant lacquer, or zinc chromate paint. If the coating is not kept intact, chlorides can greatly accelerate corrosion.

Most metal connectors used in masonry construction are of steel wire, sheet steel, or structural steel. The table in *Fig. 7-1* lists the various ASTM standards which govern these materials. Steel wire for reinforcement and connectors is cold-drawn wire made from low-carbon steel rods (ASTM A82, *Standard Specification for Steel Wire, Plain, for Concrete Reinforcement*). It is less ductile than conventional hot-rolled structural steel and has a less well-defined yield point. Stainless steel wire is nickel-chromium stainless steel (ASTM A580, *Standard Specification for Stainless and Heat-Resisting Steel Wire*) that is annealed in the manufacturing process and, as a result, has a yield stress more consistent with structural steel. Annealed nickel-chromium stainless steels are austenitic and non-magnetic. The table in *Fig. 7-2* lists properties of steel wire used in masonry.

Function	ASTM Specification	Minimum Yield Strength (psi)	Minimum Tensile Strength (psi)
Wire ties and anchors	ASTM A82 Cold-Drawn Steel Wire for Concrete Reinforcement	70,000 30,000	80,000 75,000
	ASTM A580 Stainless and Heat-Resisting Wire		
Sheet metal ties and anchors	ASTM A366 Cold-Rolled Carbon Steel Sheet, Commercial Quality	— —	— —
	ASTM A525 General Requirements for Steel Sheet, Zinc-Coated (Galvanized) by the Hot-Dip Process (Class G60)	30,000	75,000
	ASTM A167 Stainless and Heat-Resisting Chromium-Nickel Steel Plate, Sheet and Strip		
Anchor bolts	ASTM A307 Carbon Steel Bolts and Studs (Grade A)	—	—
Plate and bent bar anchors	ASTM A666 Austenitic Stainless Steel Sheet, Strip, Plate and Flat Bar for Structural Applications	30,000	75,000
Rolled shapes, lintels, and plate and bent bar anchors	ASTM A36 Carbon Structural Steel	36,000	58,000 to 80,000

Figure 7-1 ASTM standards for metals used in masonry accessories.

ASTM Wire Size	Wire Gauge No.	Nominal Diameter (in.)	Nominal Area (sq.in.)	Nominal Perimeter (in.)	Weight (lb./ft.)	Tensile Strength	
						Yield (lb.)	Ultimate (lb.)
W1.1	11	0.1205	0.0114	0.379	0.0387	798	912
W1.7	9	0.1483	0.0173	0.466	0.0587	1,211	1,384
W2.1	8	0.1620	0.0206	0.509	0.0700	1,442	1,648
W2.8	3/16 in.	0.1875	0.0276	0.589	0.1250	1,932	2,228
W4.9	1/4 in.	0.2500	0.0491	0.785	0.1667	3,437	3,928

Figure 7-2 Common wire sizes used in masonry.

Sheet metal anchors are made from either cold-rolled carbon steel (ASTM A366, *Standard Specification for Steel, Sheet, Carbon, Cold-Rolled, Commercial Quality*) or stainless steel (ASTM A167, *Standard Specification for Stainless and Heat-Resisting Chromium-Nickel Steel Plate, Sheet, and Strip, Type 304*). The table in Fig. 7-3 lists sheet metal thicknesses and standard gauges. Steel reinforcing bars may conform to a number of ASTM standards depending on the strength desired. Structural steel used for lintels, shelf angles, or strap anchors should conform to ASTM A36, *Standard Specification for Structural Steel*.

Corrosion of metals occurs from weathering, direct chemical attack, and galvanic action. Since most metals used in masonry construction are concealed within the masonry, exterior weathering is generally not a concern. However, corrosion may be caused by prolonged exposure to moisture which condenses within a wall section or in open cavities or collar joints, water which penetrates the exterior face shell of single-wythe walls or the exterior wythe of cavity or veneer walls, or atmospheric humidity in excess of 75% in hollow cores and

Gauge	Thickness (in.)	Weight (oz./sq.ft.)
10	0.1345	90
12	0.1046	70
14	0.0747	50
16	0.0598	40
18	0.0478	32
20	0.0359	24
22	0.0299	20
24	0.0239	16
26	0.0179	12
30	0.0149	10

Figure 7-3 Sheet metal properties.

cavities. Direct chemical attack can be caused by chlorides, and set-accelerating admixtures which contain calcium chloride should not be used in masonry mortar. Deep carbonation of mortar caused by carbon dioxide intrusion through cracks or voids at the mortar-to-unit interface may also accelerate corrosion of metal anchors, ties, or reinforcement embedded in the mortar. Some metal corrosion in masonry is caused by galvanic action. Galvanic action causes corrosion between dissimilar metals in the presence of an electrolyte (such as water).

All steel used in masonry, with the exception of reinforcing bars and wire fabric, should be galvanized or stainless steel. Although zinc is also susceptible to corrosive attack, it is used in the galvanizing process to provide both a barrier coating to isolate the steel from corrosive elements, and a sacrificial anodic coating that is consumed to protect the base steel at uncoated areas such as scratches and cut ends. Although corroded metal occupies a greater volume than the original material and exerts expansive pressures around the embedded item, the film of zinc used to galvanize masonry accessories is so thin that the pressure is insufficient to crack the masonry. If the masonry is absorbing excessive moisture because of design or construction defects, however, corrosion of the steel may continue and the expansive pressures increase substantially over time. As this “rust jacking” continues, the masonry is cracked, allowing even more moisture to enter the wall.

The table in *Fig. 7-4* lists the corrosion protection requirements for masonry accessories found in the Masonry Standards Joint Committee (MSJC) *Specifications for Masonry Structures* (ACI 530.1/ASCE6/TMS 602). Masonry accessories in exterior walls and interior walls exposed to relative humidities of 50% or higher should be hot-dip galvanized after fabrication in accordance with ASTM A153, *Standard Specification for Zinc Coating (Hot-Dip) on Iron and Steel Hardware*, Class B. Mill galvanizing and electrogalvanizing do not provide protection at sheared edges, wire ends, shop welds, penetrations, and so on. For interior walls exposed to lower humidity, joint reinforcement can be zinc coated in accordance with ASTM A641, *Standard Specification for Zinc Coated (Galvanized) Carbon Steel Wire*. The life expectancy of the corrosion protection afforded by galvanizing is directly proportional to its thickness (*see Fig. 7-5*). Stainless steel accessories are less

Masonry Standards Joint Committee Specification for Masonry Structures (ACI 530.1/ASCE 6/TMS 602) Requirements for Corrosion Protection ³			
Accessory Item	ASTM Standard ⁴	Class	Weight or Thickness of Coating
Galvanized Coatings			
Joint reinforcement, interior walls	A641	1	0.10 oz/sq.ft.
Wire ties or anchors in exterior walls completely embedded in mortar or grout	A641	3	0.80 oz/sq.ft.
Wire ties or anchors in exterior walls not completely embedded in mortar or grout	A153	B2	1.50 oz/sq.ft.
Joint reinforcement in exterior walls or interior walls exposed to a mean relative humidity exceeding 75% (e.g., food processing or swimming pool)	A153	B2	1.50 oz/sq.ft.
Sheet metal ties or anchors in exterior walls or interior walls exposed to a mean relative humidity exceeding 75% (e.g., food processing or swimming pool)	A153	B2	1.50 oz/sq.ft.
Sheet metal ties or anchors in interior walls	A653	G60	0.60 oz/sq.ft.
Steel plates and bars (as applicable to size and form indicated)	A123 A153	— B	— —
Epoxy Coatings			
Joint reinforcement	A884	B2	18 mils
Wire ties and anchors	A899	C	20 mils
Sheet metal ties and anchors	—	—	20 mils [†]

³ Corrosion protection may also be provided by using AISI Type 304 stainless steel as follows:

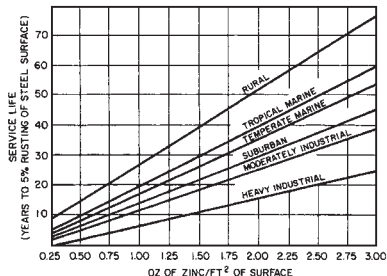
joint reinforcement, ASTM A580 *Stainless and Heat-Resisting Steel Wire plate and bent bar anchors*, ASTM A666 *Austenitic Stainless Steel Sheet, Strip, Plate and Flat Bar for Structural Applications*
sheet metal ties and anchors, ASTM A167 *Stainless and Heat-Resisting Chromium-Nickel Steel Plate, Sheet and Strip*
wire ties and anchors, ASTM A580 *for Stainless and Heat-Resisting Steel Wire*

⁴ ASTM A641 *Zinc Coated (Galvanized) Carbon Steel Wire*
ASTM A153 *Zinc Coating (Hot-Dipped) on Iron and Steel Hardware*
ASTM A653 *Steel Sheet, Zinc-Coated (Galvanized) or Zinc-Iron Alloy-Coated (Galvanealed) by the Hot-Dip Process*
ASTM A884 *Epoxy-Coated Steel Wire and Welded Wire Fabric for Reinforcement*
ASTM A899 *Steel Wire Epoxy Coated*

[†] Per surface or manufacturer's specification.

Figure 7-4 Required corrosion protection for masonry accessories. (From *Masonry Standards Joint Committee, Specifications for Masonry Structures, ACI 530.1 ASCE 6/TMS 602.*)

susceptible to corrosion and provide greater long-term durability for masonry construction. Stainless steel will provide the highest corrosion protection in severe exposures, and should conform to Series 300, ASTM A167, *Standard Specification for Stainless Steel and Heat-Resisting Chromium-Nickel Steel Plate, Sheet, and Strip*. ASTM Committee C15 on Manufactured Masonry Units is in the process of developing a standard guide for corrosion protection



(Adapted from American Galvanizers Association.)


Life Expectancy of Masonry Cavity Wall Ties (years) ¹					
Probability of Occurrence (%)	Corrosion Rate (10 ⁴ oz. zinc per sq.ft./year)	ASTM A153, Class B2		ASTM A153, Class B1	
		Minimum	Average	Minimum	Average
5	2415	5.2	6.2	7.5	8.3
10	1791	7.0	8.4	10.1	11.2
20	1075	11.6	14.0	16.7	18.6
25	875	14.3	17.1	20.6	22.9
33	656	19.1	22.9	27.4	30.5
50	393	31.8	38.2	45.8	50.9

¹ Data taken in climatic areas with a driving rain index of 2.5 to 5.0 (see Chapter 9). (Adapted from Clayford T. Grimm.)

Figure 7-5 Life expectancy of galvanized coatings.

of embedded metals in masonry. The standard is intended to establish minimum acceptable levels of corrosion protection for ties, anchors, fasteners, and inserts based on exposure conditions and perhaps even to a driving rain index (refer to Chapter 9).

The degree of galvanic corrosion which can occur between dissimilar metals depends on the intimacy of contact, the type of electrolyte, and the voltage developed between the two metals. An electric current is conducted through the electrolyte, corroding one metal (the anode) and plating the other (the cathode). The greater the potential difference between the two metals, the more severe is the corrosion. The metal that is lower in the galvanic series table is subject to corrosion by metals higher in the series (see Fig. 7-6). The density of the corrosion current is also important, or the size of the current relative to the anode surface. If a fastener has a surface that is small compared to the metal to be fastened, its current density will be high and therefore subject to rapid corrosion. Therefore, as a general rule, a fastener in a given environment should be more noble than the material to be fastened.

Metal or Alloy	Rank in Series	
Platinum	Cathode (-) Most Noble	
Gold		
Graphite		
Titanium		
Silver		
Austenitic stainless steel (passive)		
Ferritic stainless steel (passive)		
Nickel (passive)		
Silver solder		
Monel		
Bronze		
Copper		
Brass		
Nickel (active)		
Tin		
Lead		
Austenitic stainless steel, 18-8 series (active)		
Ferritic stainless steel, 400 series (active)		
4-6% Chromium steel		
Iron or carbon steel		
Aluminum, 2024-T4 alloy		
Cadmium		
Aluminum, 6061 alloy		
Aluminum, 5052 alloy		
Zinc		
Magnesium		(Anode (+) Least Noble)

The farther apart two metals are in the galvanic series, the greater the corrosion of the less noble metal

Figure 7-6 Galvanic series of metals.

To protect against galvanic corrosion when dissimilar metals are used, isolation can be provided by an electrical insulator such as neoprene or asphalt-impregnated felt. The table in *Fig. 7-7* lists compatibilities of metals commonly used in construction.

7.2 HORIZONTAL JOINT REINFORCEMENT

Horizontal joint reinforcement is used to control shrinkage cracking in concrete masonry unit (CMU) walls. It can also be used to tie the wythes of multi-wythe walls together, to bond intersecting walls, and to assure maximum flexural wall strength against lateral loads. The basic types of joint reinforcement available are shown in *Fig. 7-8*. Some designs are better for certain applications than others.

Compatibility of Common Building Metals						
	Copper	Aluminum	Stainless Steel	Galvanized Steel	Zinc Alloy	Lead
Aluminum	1	—	—	—	—	—
Stainless Steel	1	3	—	—	—	—
Galvanized Steel	2	3	2	—	—	—
Zinc	1	3	1	3	—	—
Lead	2	2	2	3	3	—
Brass	2	1	1	2	1	2
Bronze	2	1	1	2	1	2
Monel	2	3	1	2	1	2
Iron/Steel	1	2	2	2	1	3

- Galvanic action will occur.
- Galvanic action may occur under certain conditions or over a period of time.
- Galvanic action is insignificant under normal conditions.

Figure 7-7 Compatibility of metals.

- In single-wythe walls, two-wire ladder or truss-type reinforcement is most appropriate. Under most circumstances, the ladder type provides adequate restraint against shrinkage cracking. The truss type is stronger and provides about 35% more area of steel, but the ladder type generally interferes less with grout flow and vertical bar placement in structurally reinforced walls.
- For multi-wythe walls in which the backing and facing wythes are of the same type of masonry, three-wire joint reinforcement of either the truss or ladder-type design is suitable. If the wythes are laid up at different times, however, the three-wire design makes installation awkward. Three-wire truss-type reinforcing should never be used when insulation is installed in the cavity between wythes because it is too stiff to allow for differential thermal movement between the backing and facing wythes.
- For walls in which the backing and facing wythes are laid at different times, or walls which combine clay and concrete masonry in the facing and backing wythes, joint reinforcement with adjustable ties allows differential movement between wythes and facilitates the installation of the outer wythe after the backing wythe is already in place. The adjustable ties may be either a tab or hook-and-eye design. Joint reinforcement with adjustable ties should not be used with concrete masonry facing wythes over concrete masonry backing wythes. The concrete masonry facing requires shrinkage restraint which is not provided by the intermittent ties. For concrete masonry facings over concrete masonry backing, three-wire joint reinforcement is more appropriate.
- For uninsulated cavity walls of block and brick where the backing and facing wythes are laid at the same time, truss- or ladder-type reinforcement with fixed welded-wire tab ties can be used. It is less expensive than reinforcement with adjustable ties, but also allows less differential movement. If the cavity is insulated, the tabs restrain differential thermal movement between the backing and facing wythes. Tab-type reinforcement also does not provide shrinkage restraint for concrete masonry facing wythes.
- For projects in seismically active areas, joint reinforcement with seismic anchors is available from several manufacturers.

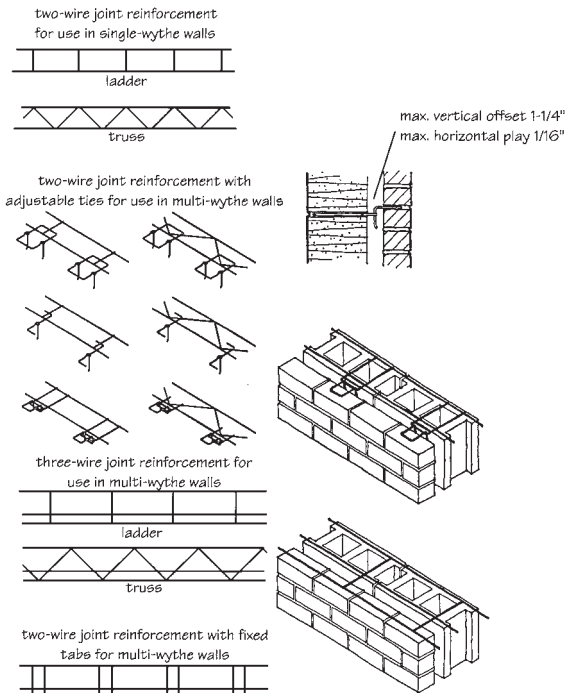


Figure 7-8 Prefabricated joint reinforcement.

The table in *Fig. 7-9* summarizes the general recommendations for using various types of joint reinforcement in various applications.

Horizontal joint reinforcement is usually made of galvanized steel wire. Spacing of the welded lateral ties should not exceed 16 in. for deformed wire or 6 in. for smooth wire. If used as structural reinforcing, the longitudinal chords *must* be of deformed wire. Joint reinforcement should conform to the requirements of ASTM A951, *Standard Specification for Joint Reinforcement for Masonry*. For exterior walls and for interior walls exposed to a relative humidity of 75% or higher, joint reinforcement should be hot-dip galvanized after fabrication in accordance with ASTM A153, Class B2. For interior walls exposed to lower humidity, joint reinforcement can be zinc coated in accordance with ASTM A641. Stainless steel joint reinforcement will provide the

Wall configuration	2-Wire ladder	2-Wire truss	3-Wire ladder	3-Wire truss	2-Wire ladder or truss with adjustable ties	2-Wire ladder or truss with fixed tabs	2-Wire ladder or truss with seismic ties
Single-wythe							
• With vertical reinforcing steel	•						
Single-wythe							
• Without vertical reinforcing steel		•					
Multi-wythe							
• Insulated cavity			•				
• Both wythes laid at same time							
• Backing and facing wythes both CMU							
Multi-Wythe							
• Uninsulated cavity			•	•			
• Both wythes laid at same time							
• Backing and facing wythes both CMU							
Multi-wythe							
• Wythes laid at different times					•		
• Backing wythe CMU, facing wythe clay masonry or stone							
Multi-wythe							
• Uninsulated cavity						•	
• Both wythes laid at same time							
• Backing wythe CMU, facing wythe clay masonry or stone							
Multi-wythe							
• Both-wythes laid at same time			•	•			
• Backing and facing wythes CMU							
• Seismic Performance Category C							
Multi-wythe							
• Wythes laid at different times							
• Backing wythe CMU, facing wythe clay masonry or stone							•
• Seismic Performance Category C							

Figure 7-9 Joint reinforcement selection guide. (Adapted from Mario Catani, "Selecting the Right Joint Reinforcement for the Job," *The Magazine of Masonry Construction*, January 1995.)

highest corrosion protection in severe exposures, and should conform to ASTM A167, Type 304.

Joint reinforcement is available in several wire diameters, and in standard lengths of 10 to 12 ft. Longitudinal wires are available in standard 9 gauge (W1.7) and extra-heavy $\frac{3}{16}$ in. (W2.8). Standard 9-gauge wire provides better fit and more practical constructability in $\frac{3}{8}$ -in. mortar joints. With extra-heavy $\frac{3}{16}$ -in. wire, there is little room for construction tolerances, and a Type M or Type S mortar is required to develop full bond strength with the steel. Heavy-gauge joint reinforcement should be used only when there is compelling engineering rationale. Cross wires are typically either 9 or 12 gauge. Fabricated joint reinforcement widths are approximately $\frac{1}{8}$ in. less than the actual wall thickness, to assure adequate mortar coverage. The

mortar cover at the exterior wall face should be at least $\frac{3}{8}$ in. Prefabricated “L” and “T” sections are used at corners and intersecting walls to prevent cracking and separation (see Fig. 7-10).

7.3 CONNECTORS

There are three different types of masonry connectors. *Anchors* attach masonry to a structural support such as an intersecting wall, a floor, a beam, or a column. This type of connector includes anchor bolts and veneer anchors used to attach masonry veneers to backing walls of non-masonry construction. *Ties* connect multiple wythes of masonry together in cavity wall or composite wall construction. *Fasteners* attach other building elements or accessories to masonry.

7.3.1 Ties

While joint reinforcement can provide longitudinal strength in addition to lateral connection between wythes, individual *corrugated* or *wire ties* function only in the lateral direction, providing intermittent rather than continuous connection. There are several shapes and configurations, different wire gauges, and various sizes to suit the wall thickness. *Woven wire mesh* is sometimes used to connect intersecting masonry walls when no load transfer is desired. This is a soft connection and requires the installation of control joints at the wall intersection (see Fig. 7-11). Wire ties should be used in open-cavity walls and grouted multi-wythe walls. Wire ties may be rigid for laying in bed joints at the same height, or adjustable for laying in bed joints at different levels (see Figs. 7-12 and 7-13). Adjustable ties also permit differential expansion and contraction between backing and facing wythes of cavity walls. This is particularly important when connecting between clay and concrete masonry because the thermal and moisture movement characteristics of the materials are so different. Crimped ties which form a water drip in the cavity are not recommended because the



Figure 7-10 Prefabricated “L” and “T” sections of joint reinforcement are used at corners and intersecting walls to prevent this type of cracking.

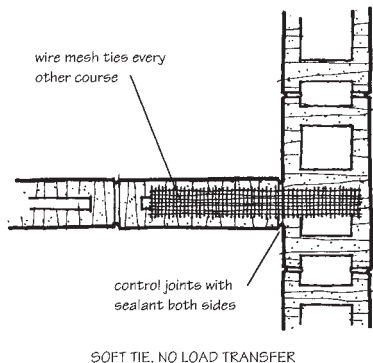


Figure 7-11 Wire mesh tie at wall intersection does not transfer loads.

deformation reduces their strength in transferring lateral loads. Crimped ties, in fact, are prohibited under some building codes because their compressive strength is only about half that of uncrimped ties. Drips are incorporated by some manufacturers by installing a plastic ring at the midsection of the wire.

Many building codes prescribe maximum tie spacing. Ties should be staggered so that no two alternate courses form a continuous vertical line, and ties should always be placed in the mortar bed rather than laid directly on the masonry unit. Structural requirements of metal wall ties can be calculated by rational design methods. Particularly in the case of adjustable ties in load-bearing construction, it is recommended that engineering analysis be used to assure adequate strength and proper performance. Adjustable ties for cavity walls should be structurally designed for each different condition of wind load, tie configuration, dimension, size, location, stiffness, embedment, modulus of elasticity of masonry, moment of inertia of each cavity wall wythe, and difference in level of connected joints.

Wire ties may be rectangular or Z shaped, in lengths of 4, 6, or 8 in. (see Fig. 7-12). Z-ties should have at least a 2-in. 90° leg at each end. Rectangular ties should have a minimum width of 2 in. and welded ends if the width is less than 3 in. Either type may be used for solid masonry (core area less than 25%), but Z-ties are less expensive. Only rectangular ties should be used in ungrouted walls of hollow masonry. Corrugated steel ties should have 0.3- to 0.5-in. wavelength, 0.06- to 0.10-in. amplitude, $\frac{3}{8}$ -in. width, and minimum 22-gauge thickness. Corrugated ties should be long enough to reach the outer face shell mortar bed of hollow units or the center of the mortar bed for solid units. Wire mesh ties should be formed of unwelded, woven wire, 16 gauge or heavier. A minimum width of 4 in. is required and a $\frac{1}{2}$ × $\frac{1}{2}$ -in. or finer mesh. Lengths may be field cut for convenience, and butt joints are acceptable.

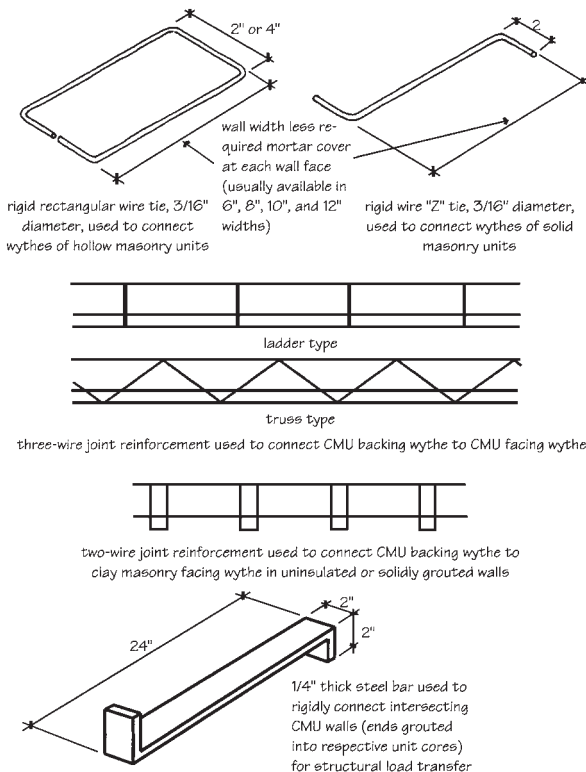


Figure 7-12 Rigid masonry ties.

Although metal ties are typically made of several materials, highest performance results from the following:

- Stainless steel, ASTM A167, Series 300
- Carbon steel, hot-dip galvanized after fabrication in accordance with ASTM A153, Class B2, and as follows:
 - Steel plate, headed and bent bar ties, ASTM A36
 - Sheet metal, ASTM A366

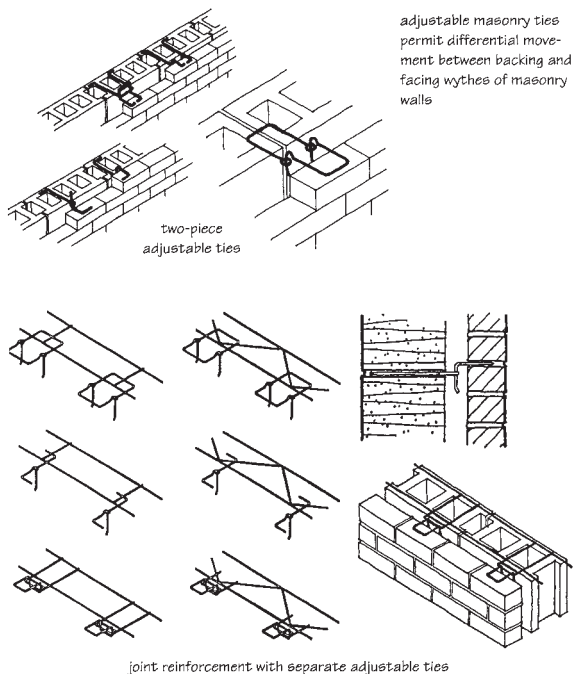


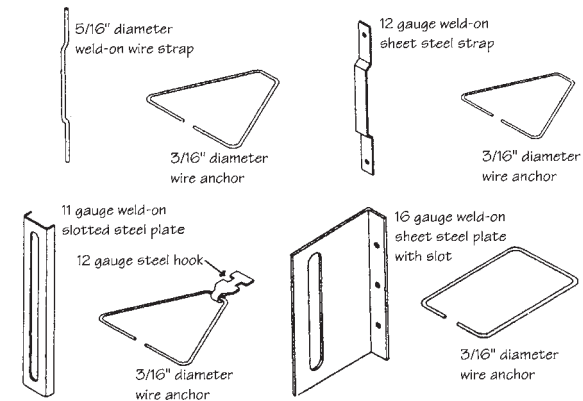
Figure 7-13 Adjustable masonry ties.

- Wire mesh, ASTM A185
- Wire ties, ASTM A82

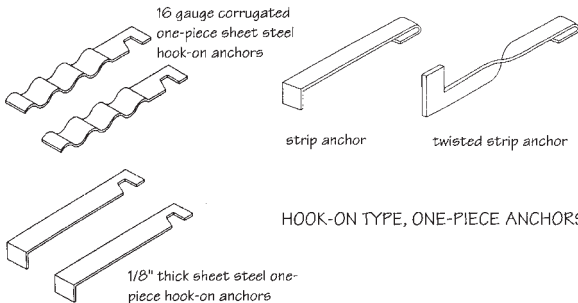
7.3.2 Anchors

Masonry veneer anchors provide connections which can resist compressive, tensile, and shear stresses. Anchors may be of either wire or sheet metal for attaching masonry veneer to steel, concrete, or stud backing (see Figs. 7-14 through 7-16). Anchors must allow differential movement between the masonry and the backing wall.

Corrugated sheet metal anchors should meet the same physical requirements as corrugated ties (0.3- to 0.5-in. wavelength, 0.06- to 0.10-in. amplitude, 3/8-in. width, and minimum 22-gauge thickness). Corrugated



WELD-ON TYPE, TWO-PIECE ANCHORS



HOOK-ON TYPE, ONE-PIECE ANCHORS

Figure 7-14 Masonry-to-steel veneer anchors.

sheet metal anchors may be used with solid or hollow units where the distance between the veneer and supporting frame is 1 in. or less and are typically limited to residential or one-story light commercial construction. One end of the anchor is nailed or screwed to a stud, and the other end is embedded in a mortar joint (see Fig. 7-15). Performance is greatly reduced if the attaching nail or screw is not located within $\frac{1}{2}$ in. of the bend. Corrugated dovetail anchors are fabricated to fit a dovetailed slot in a concrete structural frame, and are usually at least 16 gauge (see Fig. 7-16).

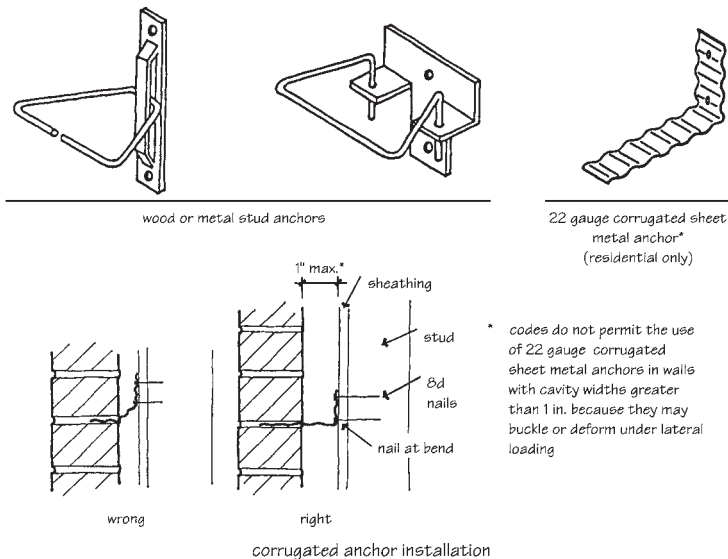


Figure 7-15 Masonry-to-stud veneer anchors.

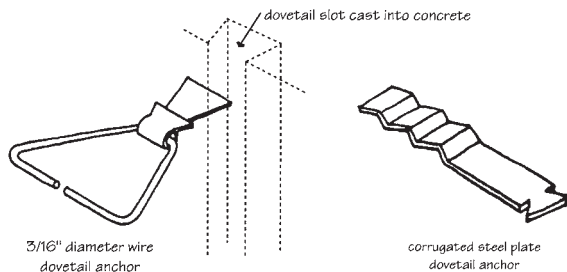


Figure 7-16 Masonry-to-concrete veneer anchors.

Building codes require special anchorage of masonry veneers in seismic areas. *Seismic anchors* typically consist of a single or double continuous reinforcing wire attached to a plate for connection to different types of backing walls (see Fig. 7-17).

Several types of proprietary anchors have also been introduced for seismic retrofitting of unreinforced masonry and for reanchoring masonry veneer. Retrofit veneer anchors are designed to

- Provide anchors in areas where they were not installed in the original construction
- Replace failed existing anchors
- Replace failed existing header bond units
- Upgrade older wall systems to current code, including seismic retrofitting of older buildings
- Attach new veneers over existing facades

The three general types are a mechanical expansion system, a screw system, and an epoxy adhesive system (see Fig. 7-18). Seismic retrofit anchors are designed to anchor existing masonry walls to existing floor and roof diaphragms for combined action under load. Seismic forces can thus be transferred from walls perpendicular to acceleration to walls parallel to acceleration, which are more capable of dissipating the force.

Figure 7-19 shows some typical anchors used to attach stone slab veneer or thin stone cladding to various structural frames. ASTM C1242, *Standard Guide for Design, Selection, and Installation of Exterior Dimension Stone Anchors and Anchoring Systems*, provides recommended guidelines for these complex anchoring systems. The standard defines several different generic types of anchors and discusses the design principles which must be considered in resisting both lateral and gravity loads. An appendix also provides information on safety factors. Stone anchors are almost exclusively made of stainless steel (ASTM A167, Type 304) to minimize corrosion and staining. Anchors for unit masonry are typically of galvanized steel or stainless steel (see Fig. 7-4).

Anchor bolts are used in masonry construction to connect sill plates and other elements for structural load transfer. Codes generally recognize plate,

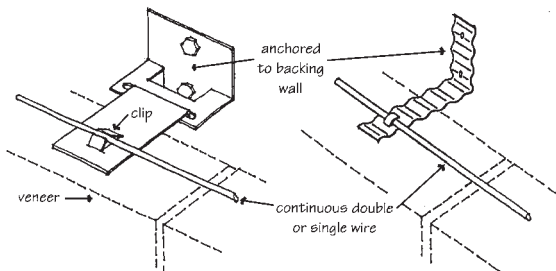


Figure 7-17 Seismic veneer anchors.

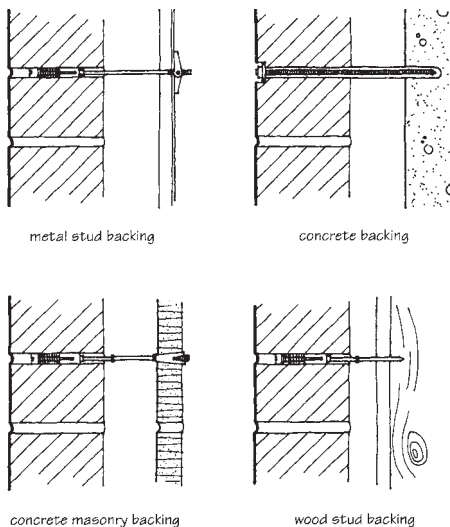


Figure 7-18 Retrofit veneer anchors. (From *BLA*, Technical Note 44B)

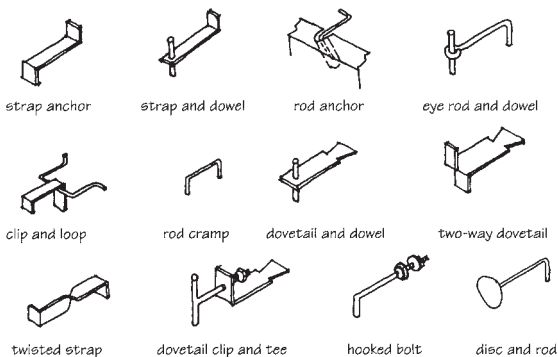


Figure 7-19 Stone cladding anchors.

headed, and bent bar anchor bolts (see Fig. 7-20). Allowable loads are based on a percentage of the strength determined by ASTM E488, *Standard Test Methods for Strength of Anchors in Concrete and Masonry Elements*. Anchor bolts should meet the requirements of ASTM A307, *Standard Specification for Carbon Steel Bolts and Studs*, Grade A, and should be hot-dip galvanized for corrosion protection.

7.3.3 Fasteners

Attaching fixtures or dissimilar materials to masonry requires some type of fastener. Most plugs, nailing blocks, furring strips, and so on can be

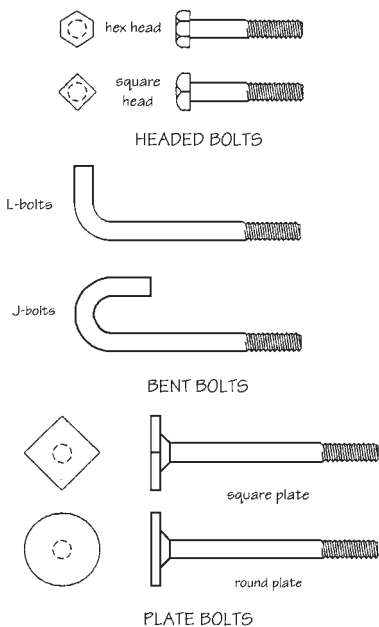


Figure 7-20 Anchor bolts for masonry. (From *Masonry Standards Joint Committee*, Building Code Requirements for Masonry Structures, ACI 530/ASCE 5/TMS 402, and Specifications for Masonry Structures, ACI 530.1/ASCE 6/TMS 602.)

installed by the mason as the work proceeds. There are a variety of products and methods from which to choose, depending largely on the kind of fixture or material to be attached and the type of masonry involved (see Fig. 7-21).

The most common method of attaching wood trim items such as baseboards or chair rails is to place *wood nailing blocks* in the vertical joints as the mason builds the wall. These blocks should be of seasoned softwood, creosoted to prevent shrinkage or rot. They should never be placed in horizontal joints. *Galvanized metal nailing plugs*, with or without fiberboard inserts, provide better construction and are easily set into the joints during construction. *Toggle bolts* and *double-threaded fasteners* can be used only with hollow masonry units, and are installed after the wall is completed. *Wood plugs with threaded hooks* can be used with either solid or hollow masonry. The plug may be built into the wall or driven into a hole drilled after construction. *Plastic or fiber plugs* can also be used with solid or hollow units. They are placed in holes drilled into either the mortar joints or face shells of the masonry. *Expansion shields* and *wedge-type bolts* may be used with solid or grouted masonry. Newer attachment methods include pins or fasteners rammed or driven into solid masonry with a power tool or gun, and direct adhesive or mastic application.

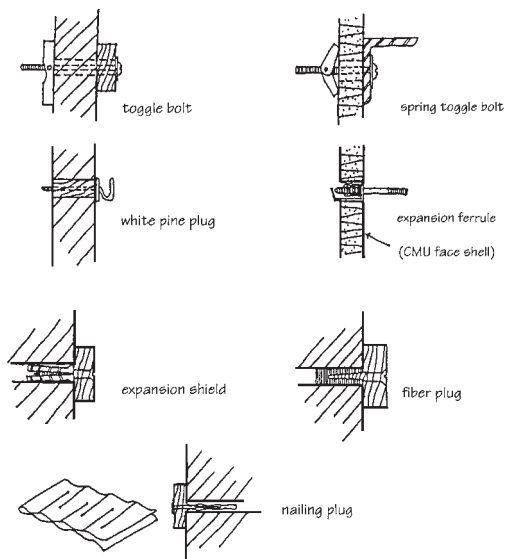


Figure 7-21 Masonry fasteners. (From BIA Technical Notes, Vol. 2, No. 10.)

Wood furring strips can be attached using nailing blocks, metal wall plugs, or direct nailing into mortar joints with case-hardened “cut nails” (wedge-shaped) or spiral-threaded masonry nails. Special anchor nails may be adhesively applied to the wall, or porous clay nailing blocks may be inserted into the bonding pattern (see Fig. 7-22). Metal furring strips are attached to the wall by tie wires built into the mortar joints or by special clips designed for this purpose.

7.4 MOVEMENT JOINT FILLERS

Concrete masonry moisture shrinkage and clay masonry moisture expansion, along with reversible thermal movement, are accommodated through special jointing techniques which allow movement without damage to the wall. Control joints for concrete masonry are designed as stress-relieving contraction points, and must extend completely through the masonry wythe. Preformed rubber or PVC shear keys transfer lateral loads across the joint while allowing it to open as the masonry shrinks (see Fig. 7-23), and should have a high-durometer hardness. Softer materials such as neoprene rubber sponge are used for expansion joints in clay masonry walls, where brick masonry expansion will compress the filler as the joint closes. Expansion joint fillers are used only to keep mortar out of the joints during construction, and should have a compressibility at least equal to that of the sealant which will be used.

7.5 BAR POSITIONERS

Proper structural function of reinforced masonry and proper interaction between grout and reinforcement require that the reinforcing bars be located in the position required by the design. Accurate positioning requires the use of special accessories or special units (see Fig. 7-24) which are capable of holding the reinforcement in place during grouting operations.

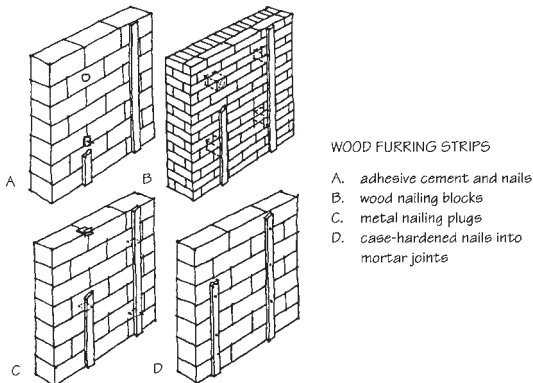


Figure 7-22 Wood furring strips. (From BIA, Technical Notes, Vol. 2, No. 10.)

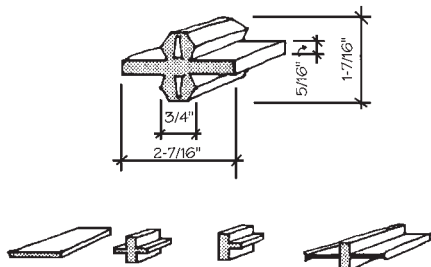


Figure 7-23 Premolded control joint fillers.

7.6 FLASHING MATERIALS

Flashing in masonry may be used as a barrier against the intrusion of water and as a moisture-collection device. All flashing materials must be impervious to moisture and resistant to corrosion, abrasion, and puncture. In addition, they must be able to take and retain an applied shape to ensure proper performance after installation.

Stainless steel flashings are highly resistant to corrosion, and provide the highest long-term durability. *Copper sheet* resists ordinary corrosive action, provides an excellent moisture barrier, and is easily shaped. Copper flashing can stain light-colored masonry, though, unless it is coated with lead or other protective material. Copper sheet or lead-coated copper sheet should be a minimum 16-oz weight. Both stainless steel and copper flashing can be “sawtoothed” or “dovetailed” in section to provide a mechanical bond with the mortar (see Fig. 7-25). *Galvanized steel* is used in both residential and commercial construction, but is subject to corrosive attack from wet mortar unless it is covered with a bituminous coating. Exterior exposures require a 26-gauge thickness, and concealed installations require 28 gauge. A minimum 28-gauge (0.015-in.) thickness is recommended. *Aluminum*, of course, is subject to corrosive damage from wet mortar and should not be used.

Copper is commonly used in *combination flashings* of 3-, 5-, or 7-oz copper sheet, and coatings of bitumen, kraft paper, bituminous-saturated cotton fabrics, or glass fiber fabrics. Combination flashings provide adequate protection at lower cost by allowing thinner metal sections. These coated metals are suitable only for concealed installations.

Plastic sheet flashings of PVC membrane may also be used in concealed locations, but may deteriorate over time. There is little long-term durability data on plastic flashing, but performance history does indicate that thickness should be at least 30 mil to avoid punctures during installation. The flashing must also be compatible with alkaline mortars and with elastomeric joint sealants. Prefabricated corners and end dams facilitate installation, and are sometimes used in combination with compatible metal flashing (see Fig. 7-26).

EPDM (ethylene propylene diene terpolymer) rubber flashing and rubberized asphalt flashing materials have been introduced in the masonry industry. EPDM flashing should be a minimum of 45 mil in thickness, and uncured strips

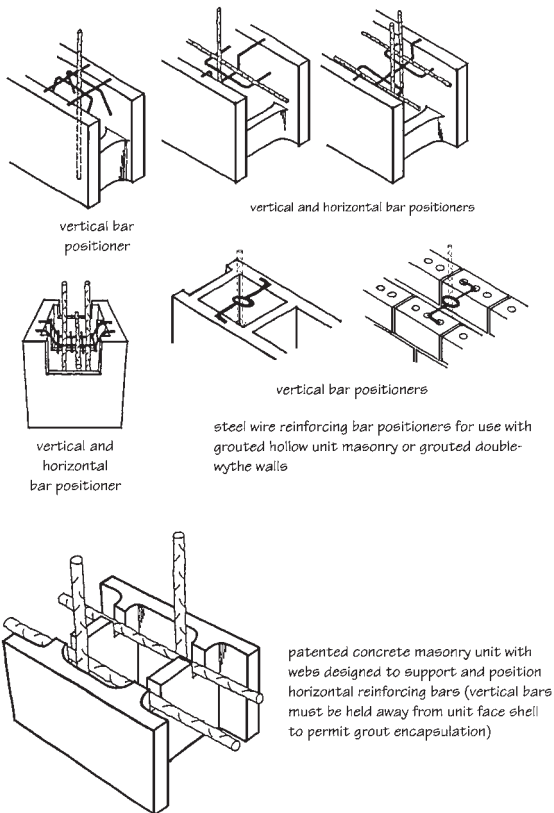


Figure 7-24 Bar positioners for masonry reinforcement.

must be used to form corners. Like EPDM roofing membranes, this rubber flashing material is seamed with a proprietary adhesive which requires careful cleaning and priming of the mating surfaces. *Rubberized asphalt* flashing is self-adhering and self-healing of small punctures. It installs quickly and easily, and is relatively forgiving of uneven substrates. However, good adhesion depends on a clean, dry substrate and temperatures that are relatively warm.

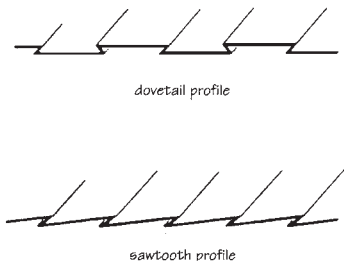


Figure 7-25 Deformed metal flashing forms a mechanical bond with the mortar.

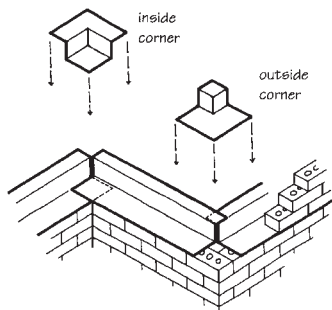


Figure 7-26 Prefabricated corner flashing.

Primers can help assure good adhesion to concrete, sheathing, and other substrates, and can make cold-weather adhesion easier to achieve than with a heat gun. Rubberized asphalt flashing cannot tolerate ultraviolet exposure. When it is necessary or desirable to extend the flashing material beyond the face of the wall, rubberized asphalt membranes must be used in conjunction with a separate metal drip edge. *Figure 7-27* lists the advantages and disadvantages of the most commonly used flashing materials.

The cost of flashing is minimal compared to the overall construction budget, and it is usually counterproductive to economize on flashing materials at the expense of durability. Flashing material selection should take into account the function, environment, and expected service life of the building. For institutional buildings and others which will be in service for long periods of time, only the most durable materials should be used.

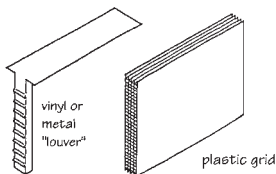
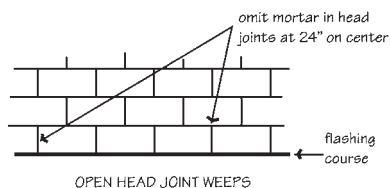
Masonry Flashing Materials			
Material	Minimum Thickness or Gauge	Advantages	Disadvantages
Stainless steel	26 gauge/0.018 in.	Very durable, non-staining	Difficult to solder and form
Cold-rolled copper	16 oz.	Flexible, durable, easily formed and jointed	Damaged by excessive flexing, can stain surfaces below where water runs off, bitumen and fire-retardant treated wood containing salts are corrosive to copper
Galvanized steel	28 gauge/0.015 in.	Durable and easy to paint	Difficult to solder, corrodes early in acidic and salty air
Lead-coated copper	16 oz.	Flexible, durable, non-staining	Heat control of soldering irons is critical, 60-40 tin-lead solder must be used, damaged by excessive flexing
Copper laminates	5 oz. (copper)	Easy to form and join	Fabric degrades in UV light, more easily torn than full copper
EPDM	45 mil	Flexible, easy to form and join, non-staining	Metal drip edge required, full support recommended
Rubberized asphalt	40 mil	Fully adhered, separate lap adhesive not needed, self-healing, flexible, easy to form and join	Full support required, degrades in UV light, metal drip edge required, difficult adhesion in cold weather, surfaces must be clean and some require priming
PVC	30 mil	Easy to form and join, non-staining, low cost	Easily damaged, full support required, metal drip edge required, questionable durability, embrittled and often cracked by age and thermal cycling

Figure 7-27 Flashing types and properties.

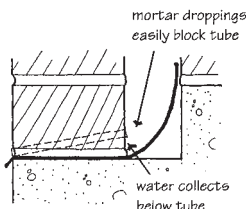
7.7 WEEP HOLE ACCESSORIES

Masonry walls are designed to drain moisture. Without effective weep holes in the course above flashings, walls collect moisture and hold it like a reservoir. The most common type of weep hole is the open-head joint, which provides the largest open area and thus the most effective evaporation and drainage. Mortar is left out of brick masonry head joints every 24 in., leaving open channels that are $\frac{3}{8}$ in. wide \times course height \times veneer depth. The primary drawback to open-joint weeps is appearance. A dark shadow is created at each opening, particularly with light-colored units and mortar. The openings are so large, in fact, that building maintenance crews all too often caulk the weep holes shut, mistakenly thinking they are the source of leaks. Some products camouflage the open joints but still allow them to work properly. One is a vinyl or aluminum cover with louver-type slots. Another is a plastic grid $\frac{3}{8}$ in. wide \times course height \times veneer depth less a $\frac{1}{8}$ -in. recess (see Fig. 7-28). Both types disguise the openings and still permit drainage and evaporation.

Hollow plastic or metal tubes are also used to form weep holes. The most common ones are $\frac{3}{8}$ in. or $\frac{1}{2}$ in. in diameter by $3\frac{1}{2}$ to 4 in. long. Manufacturers recommend installing them at an angle in the mortar of the head joints, spaced 16 in. apart. The slight angle allows for a very small amount of mortar droppings in the cavity. The closer spacing is required because less water can drain through the tube, and less air can enter the wall, making drainage and evaporation much slower. Tube-type weep holes are less conspicuous in the finished wall than open joints, but they are easily clogged by mortar or insects, and are not recommended. Some manufacturers make larger, rectangular tubes which measure $\frac{3}{8} \times 1\frac{1}{2} \times 3\frac{1}{2}$ in. Since the opening is much larger, blockage is not a problem, but the weep holes are more noticeable.



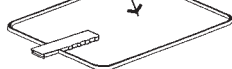
WEEP INSERTS CHANGE APPEARANCE OF OPEN HEAD JOINTS



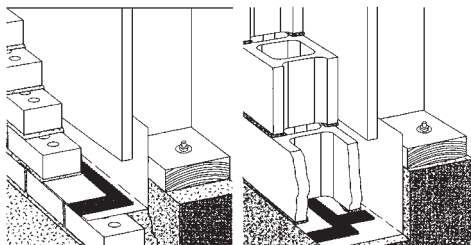
PLASTIC WEEP TUBES ARE NOT RECOMMENDED

Comparison of Most Common Weep Types			
Weep Type	Advantages	Disadvantages	Recommended Spacing (in.o.c.)
Open head joint	Maximum drainage rate, ventilation	Appearance, insect intrusion	24 (brick) 32 (block)
Open joint with insert	Good drainage rate	Extra cost	24 (brick) 32 (block)
Cotton rope wick	Appearance	Slower drainage	16 (brick only)
Plastic tube	Appearance	Easily blocked	16 (brick only)

place one tray over each unit core in weep course immediately above flashing



plastic tray for hollow unit masonry



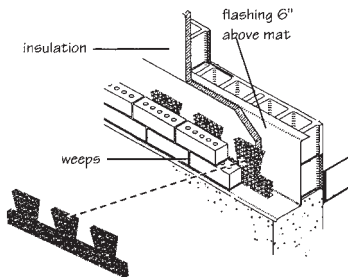
corrugated plastic weep system for drainage cavity

corrugated plastic weep system for hollow unit cores and drainage cavity

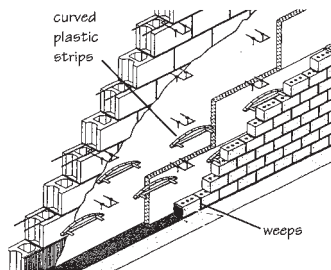
EXAMPLES OF PROPRIETARY WEEP SYSTEMS

Figure 7-28 Weep accessories.

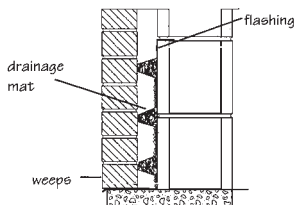
Cotton wicks are used to form another type of weep system. A $\frac{1}{4}$ - to $\frac{3}{8}$ -in.-diameter rope is installed in the joints at 16 in. on center. The rope should be 8 to 10 in. long, and extend through the veneer face and up into the cavity well above the height of any mortar droppings. Moisture in the cavity is absorbed by the cotton material and wicked to the outside face of the wall,



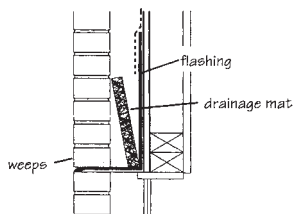
ARTICULATED WOVEN FILAMENT



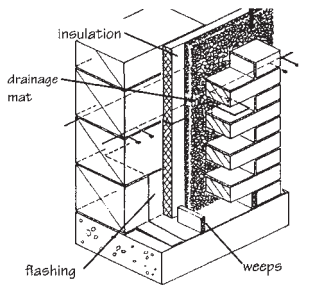
PLASTIC DIVERTER STRIPS



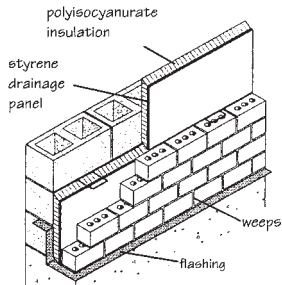
WOVEN FILAMENT MAT WITH STAGGERED PROTRUSIONS



FLAT WOVEN FILAMENT MAT



WOVEN FILAMENT MAT ADHERED TO POLYSTYRENE INSULATION



POLYISOCYANURATE INSULATION WITH ADHERED DRAINAGE PANEL

Figure 7-29 Drainage accessories.

where it evaporates. This is a slower process than open weeps, and nylon or hemp rope will not perform well. The cotton will be wet throughout its service life, and eventually will rot, leaving an open drainage hole. Using cotton wicks, however, assures that drainage is not inadvertently blocked by mortar. Wicks are also inconspicuous in the wall.

Another alternative is oiled rods or ropes which are mortared into the joints at 16 in. on center and then removed when the mortar has set. The rods function much the same as plastic tubes, and share some of the same disadvantages. The $\frac{3}{8}$ -in.-diameter rods used are generally $3\frac{1}{2}$ to 4 in. long, oiled slightly to prevent mortar bond, and extended through the veneer thickness to the core or cavity. The opening left after removal is a full $\frac{3}{8}$ in., since the thickness of the tube shell is eliminated, but the hole is still small and easily blocked by mortar droppings. To avoid this, the rods can be left in place until the full story or panel height of the wall above is completed. The oiled rope technique is similar to that of the wick system, in that an unobstructed drainage path is provided. After the wall is completed to story height, the rope can be removed. The rope should be 10 to 12 in. long to allow adequate height in the cavity and to provide a handle for removal. By removing the rope instead of using it as a wick, the hole provides more rapid evaporation at the outset of construction, and its size is less noticeable than open-head joint weeps.

7.8 DRAINAGE ACCESSORIES Weep holes are not effective if the flow of moisture in the wall cavity is obstructed by mortar droppings. Some contractors put a shallow layer of gravel in the bottom of the cavity to promote drainage and keep mortar droppings away from the weeps. There are a number of proprietary products on the market which are more effective in breaking up mortar droppings than pea gravel in the bottom of the cavity (see *Fig. 7-29*). These products are intended to maintain a moisture flow path to the weeps, but should be used in conjunction with the techniques described in Chapter 15 for minimizing the amount of mortar in the wall cavity.

This page intentionally left blank.

PART **3**

BUILDING SYSTEMS AND APPLICATIONS

This page intentionally left blank.

8

WALL TYPES AND PROPERTIES

Masonry can be used structurally or as veneer. Masonry walls may be single- or multi-wythe, solid or hollow, grouted or ungrouted, and reinforced or unreinforced, depending on the structural requirements of the design.

Masonry is non-combustible and, in its various forms, can be used as both structural and protective elements in fire-resistive construction. Masonry is durable against wear and abrasion, and most types weather well without protective coatings. The mass and density of masonry also provide efficient thermal and acoustical resistance. Although masonry is one of the most durable of building materials, masonry construction is durable only if the component materials are of equally high quality and the detailing adequately provides for movement and weather resistance. Almost any masonry material or combination of materials can be used to satisfy functional requirements, including fire, sound, and thermal separation criteria. Specific material types, however, are generally selected on the basis of aesthetic criteria such as color, texture, and scale.

Masonry walls can be constructed with a single wythe (or single-unit thickness) or with multiple wythes. Multiple wythes may be contiguous, interlocked by overlapping units, or separated by an air space or cavity. When single wythes of masonry are attached to non-masonry backing walls, they are called *veneers* (see Fig. 8-1). For *single-wythe* curtain wall and loadbearing applications, vertical reinforcing can be placed in the hollow cores and horizontal steel in bond beam units. Where walls are also required to accommodate electrical conduit or plumbing piping, *multi-wythe* walls are more appropriate. The backing and facing wythe may be of the same or of dissimilar materials. A multi-wythe *composite wall* is one in which both the backing and facing wythe share applied axial loads.

Multi-wythe walls are more resistant to moisture penetration than single-wythe walls. Exterior exposures can be designed as *cavity walls* with an open separation of at least 2 in. between the facing and backing wythes.

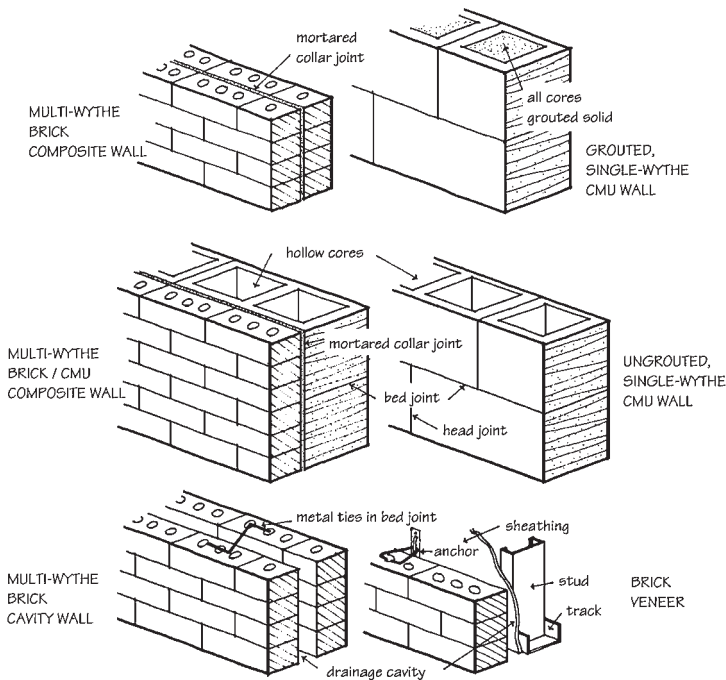


Figure 8-1 Examples of masonry wall types.

The open cavity, when it is properly fitted with flashing and weep holes, functions as a drainage system for moisture which penetrates within the wall section. Single-wythe walls are more susceptible to moisture penetration and must also be designed with a system of flashing and weep holes to divert collected moisture to the outside.

Masonry which supports the live and dead loads of floor and roof systems is said to be *loadbearing*. Masonry which supports only its own weight and resists only lateral wind, soil, or seismic loads is said to be *non-loadbearing*. Loadbearing masonry is a viable and economical structural system for many building types of either low-, medium-, or high-rise design. It is strong in compression, but requires the incorporation of reinforcing steel to resist tensile and flexural stresses. Repetitive, compartmentalized plans for hotels, multi-family

housing, nursing homes, and other occupancies are particularly suited to the linear orientation of loadbearing walls and the characteristic fire resistance of masonry. Office buildings, schools, manufacturing facilities, and other occupancies requiring large open spaces might combine a loadbearing masonry wall system at the core and perimeter with interior columns of steel, concrete, or masonry. Loadbearing masonry exterior walls should also be considered in lieu of frame-and-veneer systems whenever the selected veneer is a masonry material with structural capability, such as brick, concrete block, or mortar-bedded stone. Structural masonry is discussed at length in Chapter 12.

8.1 SINGLE-WYTHE WALLS

Within the restrictions of height-to-thickness ratios prescribed by the model building codes (see Chapter 12), walls may be empirically designed with a single unit thickness of clay, concrete, stone, or glass masonry (see Fig. 8-2). Single-wythe walls of hollow units provide the options of grouting the cores for greater mass, stability, and water-penetration resistance, or adding steel reinforcement for flexural strength. Grouted, reinforced concrete block and hollow brick walls of a single 8-in., 10-in., or 12-in. thickness can be used in low-, medium-, and high-rise loadbearing structures and in multi-story curtain wall applications (see Fig. 8-3).

Hollow structural clay tile can be used in single-wythe construction of interior walls and partitions, and in some instances of exterior walls. Facing tile and Type II glazed tile provide a finished surface on both faces of a single-wythe wall, with only one unit thickness for simplified construction. Standard structural tile designed to receive plaster applications can also be used in through-the-wall applications of one wythe. Type I glazed units are designed for finished exposure on only one side, where the other wall face will be concealed or will receive a plaster finish.

Hollow clay brick and solid brick with a 6-in. bed depth are often used in single-wythe construction, and in some instances, codes permit 4-in. walls. Hollow brick sections are usually at least 8 in. thick. Hollow architectural concrete blocks have decorative finishes on only one side. The opposite wall face must receive paint, plaster, gypsum board, or other material if exposed to view. Single-wythe walls of brick or block may be loadbearing or non-loadbearing.

Glass block masonry is used for high-security glazing, and for glazed areas requiring light control and/or heat-gain reductions. The units are used only in single-wythe construction, and do not have loadbearing capabilities.

8.2 MULTI-WYTHE WALLS

For larger horizontal or vertical spans between lateral supports or stiffeners, or for greater resistance to fire, sound, and heat transmission, wall thicknesses are increased by adding additional wythes of masonry of the same type unit or of a different material.

Multi-wythe masonry walls have been used in building construction throughout history. Strength, stability, and insulating value all depended on mass, and code requirements for empirically based, unreinforced bearing walls prescribed substantial thicknesses. The Monadnock Building in Chicago, completed in 1891, is 16 stories high with unreinforced loadbearing brick walls ranging in thickness from 12 in. at the top to more than 6 ft at the ground. At that time, wall wythes were bonded together with masonry unit headers as shown in Fig. 8-4. In 8-in. walls, header courses extend the full width of the wall section, allowing moisture to penetrate easily from exterior

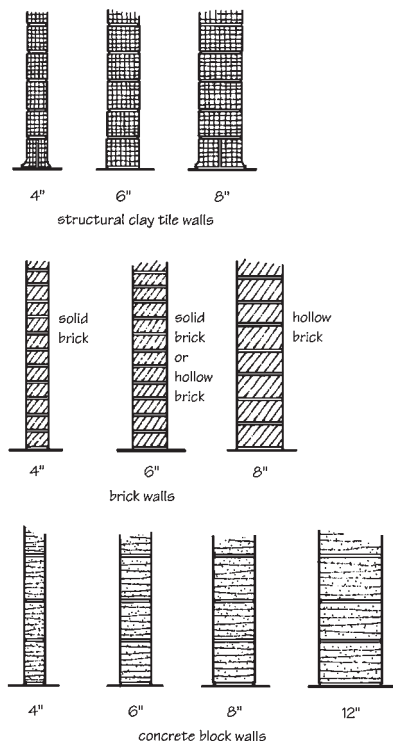


Figure 8-2 Single-wythe walls.

to interior. For the most part, masonry headers have been replaced by metal wall ties placed in the mortar bed joints. Today, masonry walls do not generally exceed 12 in. in thickness except under special conditions or circumstances. Multiple wythes that are connected to one another exhibit composite action in response to loads (see Fig. 8-5). Wythes that are flexibly connected react to loads differently (see Fig. 8-6).

Cavity walls consist of two or more wythes of masonry units separated by an air space at least 2 in. wide. The wythes may be brick, clay tile, concrete block, or stone, anchored to one another with metal ties which span the open collar joint (see Fig. 8-7). One of the major advantages of cavity wall construc-

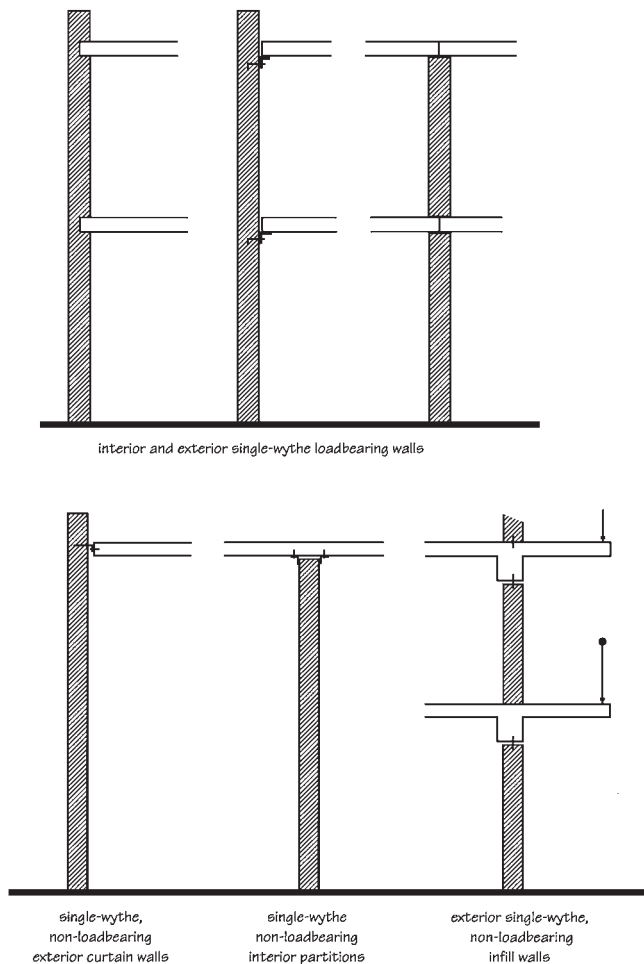


Figure 8-3 Loadbearing and non-loadbearing single-wythe walls.

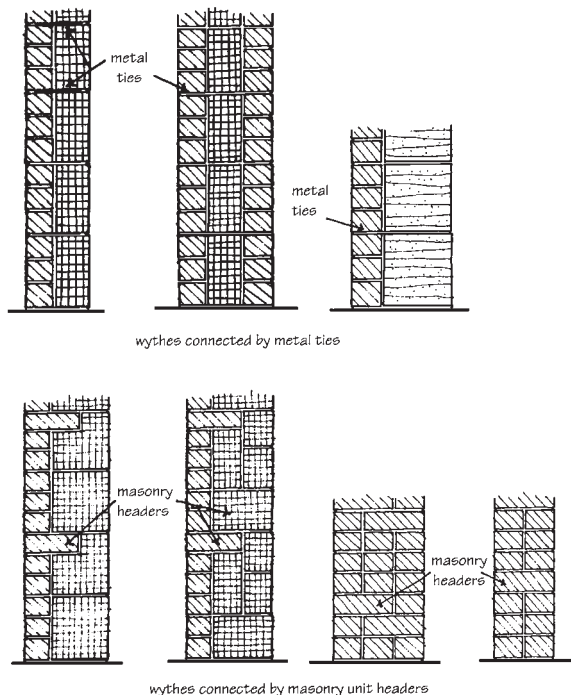


Figure 8-4 Masonry unit bonded and metal-tied masonry walls. (From Principles of Clay Masonry Construction, Brick Industry Association, Reston, VA.)

tion is the increased resistance to rain penetration which results from the physical separation of the inner and outer wythes. This separation also increases thermal resistance by providing a dead air space, and allows room for additional insulating materials if desired. The open cavity, when it is properly fitted with a system of flashing and weep holes, provides drainage for moisture which may penetrate the exterior or form as condensation within the cavity.

Both wythes of a cavity wall must resist wind loads and other lateral forces. Metal ties transfer these loads from one wythe to the other in tension and compression, and must be solidly bedded in the mortar joints in order to perform properly. Crimped ties with a water drip in the center should not be used, because the weakened plane created can cause buckling of the tie and ineffective load transfer.

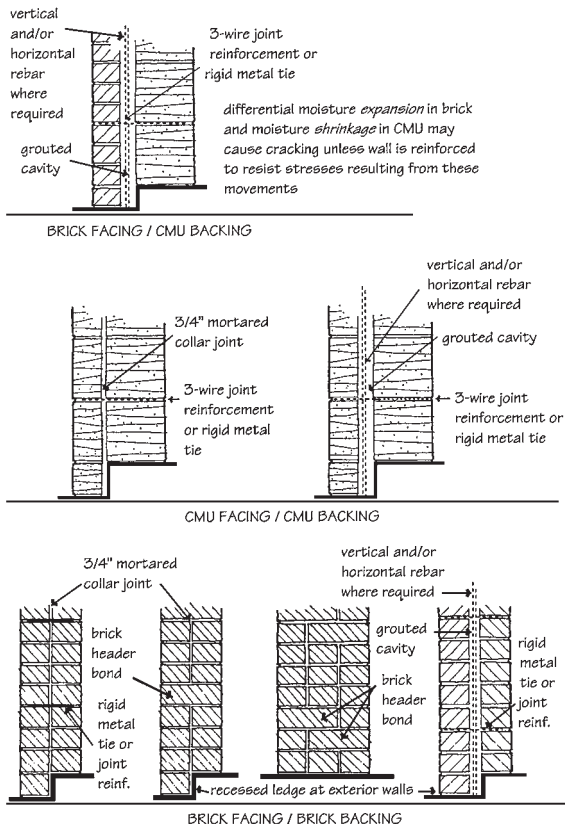


Figure 8-5 Composite masonry walls. (From Beall and Jaffe, *Concrete and Masonry Databook*, McGraw-Hill, New York, 2003.)

Cavity walls can prevent the formation of condensation on interior surfaces, so that plaster and other finish materials may be applied directly, without furring. Insulation may be added in the wall cavity, including water-repellent vermiculite, silicone-treated perlite, or rigid boards. A vapor barrier or dampproof coating is usually required on the cavity face of the inner wythe (refer to Chapter 10).

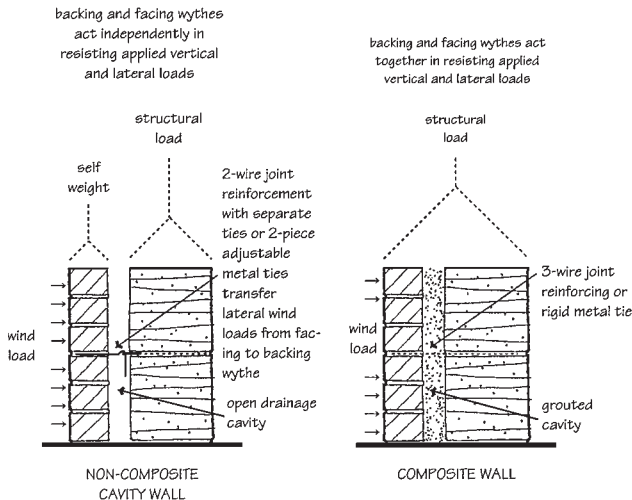


Figure 8-6 Load distribution in multi-wythe composite and non-composite walls. (From Beall and Jaffe, *Concrete and Masonry Databook*, McGraw-Hill, New York, 2003.)

8.3 VENEER WALLS

Masonry over a backing wall of non-masonry materials functions as a decorative veneer. Masonry veneers may be adhered to solid backing walls, but are more commonly attached with metal anchors. An open cavity between backing and facing allows drainage of moisture which penetrates the wall or condensate which forms within it. Masonry veneers over wood stud or metal stud walls are popular in residential and some light commercial construction (see Fig. 8-8). Stud backing walls are vulnerable to corrosion and decay and the sheathing materials often support mold growth, so veneer walls must be properly designed to protect the components of the assembly as well as the interior building space. Chapter 10 includes guidelines for detailing masonry veneers.

Masonry veneer can be constructed with adhesive or mechanical bond, over a variety of structural frame types and backing walls. Veneer applications of masonry are appropriate when the appearance of a masonry structure is desired but a loadbearing wall design is not considered appropriate. Masonry veneers may be used on buildings of wood, steel, or concrete structural frames. Brick, concrete block, stone, and terra cotta are the most commonly used veneer materials. Thin veneers may be attached adhesively with mortar over a solid backing, but codes limit the weight, size, and thickness of units. Veneers attached with metal anchors are more common, particularly in commercial applications. In skeleton frame construction, both brick and block veneers can be designed as reinforced curtain walls spanning vertically or

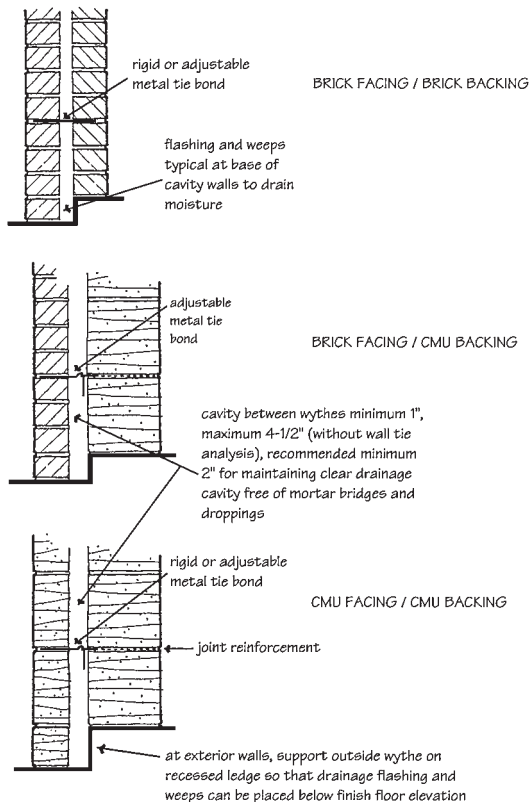
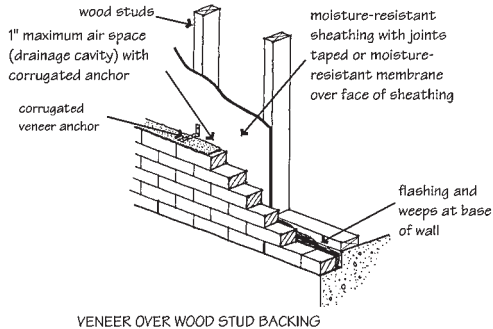


Figure 8-7 Multi-wythe cavity walls.

horizontally between supports. Codes generally permit the waiver of intermediate support requirements when such special design techniques are approved by the building official. When applied in this manner, masonry veneers may be constructed to 100 ft or more in height without shelf angles. More typically, however, masonry veneers are designed empirically as panel walls supported at each floor level. Masonry veneers are discussed in detail in Chapter 10.



minimum 2" air space is recommended to minimize mortar bridges and increase drainage, but requires wire anchors instead of corrugated sheet metal anchors

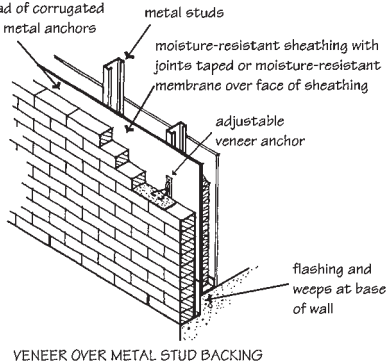


Figure 8-8 Masonry veneer walls.

8.4 FIRE RESISTANCE CHARACTERISTICS

Building fires are a serious hazard to life and property, and fire safety in construction is therefore a primary consideration of every building code authority. According to the National Fire Protection Association (NFPA), construction deficiencies are a major factor in large-loss fire experiences. NFPA records show that combustible construction is the predominant cause of conflagrations, particularly in areas of closely built wood frame structures,

which includes single-family and most low-rise multifamily residential buildings. Restricting the spread of fire is critical in reducing fire deaths and property loss. The overwhelming majority of U.S. fires are in residential buildings—apartments, hotels, and dwellings. Multi-family occupancies are particularly vulnerable because of the lack of physical separation between living units.

While most industrialized countries require a 2-hour fire wall between units, the United States does not yet do so, which results in greater loss of life and property each year. “One-hour” construction made of combustible materials and electronic detection and suppression systems provide a false sense of security based on unrealistic fire ratings and a reliance on poorly maintained, seldom-tested fire alarm and sprinkler equipment.

Fire regulations are concerned primarily with the safety of occupants, the safety of fire fighters, the integrity of the structure, and the reduction of damage. Construction must (1) limit the spread of fire within a building; (2) prevent fire spread to adjacent buildings; (3) maintain the integrity of occupant evacuation routes; and (4) allow for attack by fire services. The overall risk is reduced when non-combustible construction is used to construct or protect structural elements, and to divide a building into compartments for the containment of fire. Non-combustible masonry and concrete construction provide the highest level of protection through fire wall containment and structural integrity.

The degree of fire protection offered by masonry construction was recognized long ago. In 1212 A.D. an ordinance was issued by royal proclamation requiring that all alehouses in London be built of masonry. After the great fire of 1666, which destroyed most of London, King Charles II decreed that the walls of all new buildings must be of masonry. Modern masonry construction has an excellent performance record in fire containment, but non-combustible construction is not required in low-rise multifamily buildings, and standard fire ratings are misleading about the relative fire safety of different types of construction. “Fire-restrictive” construction with combustible materials is an oxymoron, and sprayed fireproofing on steel framing is subject to abrasion and delamination which leave the structure essentially unprotected.

8.4.1 Fire Tests

Fire properties of building materials are divided into two basic categories: *combustibility* and *fire resistance*. Masonry is classified as non-combustible. Fire resistance ratings are based on standard ASTM, NFPA, or National Institute of Standards and Technology (NIST) fire endurance tests. Under these fire test standards, walls, floors, roofs, columns, and beams are tested in a furnace under controlled laboratory conditions. For walls, one end of the furnace is sealed with the actual construction assembly being tested so that one side of the wall is exposed to the fire.

Specimens are subjected to controlled heat applied by standard time-temperature curve for a maximum of 8 hours and 2300°F. Wall assemblies must also undergo a hose stream test for impact, erosion, and thermal shock. Throughout the tests, columns and bearing walls are loaded to develop full design stresses. Within 24 hours after the testing is complete, bearing walls must also safely sustain twice their normal superimposed load to simulate, for instance, a roof collapse. Fire resistance ratings, generally in 1- or ½-hour increments, are assigned according to the elapsed time at which the test is terminated. The test is terminated when any one of three possible end-point criteria is reached: (1) an average temperature rise of 250°F or a maximum

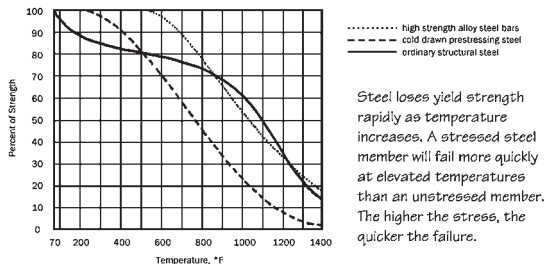
rise of 350°F is measured on the unexposed side of the wall; (2) heat, flame, or gases escape to the unexposed side, igniting cotton waste samples; or (3) structural failure occurs. The first two points concern only the containment of fire spread through the wall or section, while the third concerns structural failure and the consequent threat to life and property. Despite this fundamental disparity in the level of safety provided, each of the criteria carries equal weight in determining assigned fire ratings.

Fire ratings for “protected” construction with gypsum board or sprayed fireproofing are based on structural collapse. Fire ratings for concrete and masonry are based on heat transmission. The temperature on the unexposed side of a masonry wall rises 250°F while a “protected” wall collapses and allows the fire to spread, and yet the two assemblies are given an identical fire rating (see Fig. 8-9). Sprayed fireproofing can provide temporary protection for structural steel, but only if it is well adhered and intact. Because steel has high thermal conductivity, damaged fireproofing in one area can expose other areas to elevated temperatures. Inadequate thickness, abrasion, and delamination reduce the time it takes for a fire to weaken the steel and cause structural failure. Structural steel can lose 50% of its strength at temperatures as low as 1100°F. Open-web joists can collapse in less than 15 minutes if they are unprotected.

Masonry walls can withstand the impact of a hose stream after extended fire exposure, and are required to do so by ASTM E119, *Standard Method of Fire Tests of Building Construction and Materials*. Drywall assemblies generally cannot withstand the hose stream test and, in order to achieve their rating, a second test assembly may be substituted for the hose stream portion of the test. ASTM E119 allows this substitute wall to undergo the hose test after fire exposure for only half the rated time. During real fires, it is not possible to substitute a second wall. Firefighters who survived the World Trade Center collapse were reported to have said that “stairwell protected by concrete... would have resulted in fewer casualties.” A retired NYFD deputy chief added that NIST “should evaluate the substitution of drywall for concrete blocks when enclosing stairways and elevator shafts in high-rise buildings. Powerful hose streams collapse [the drywall]. They don’t do that with the concrete.” (As reported in “Clearing a Vertical Path to Safety,” *Building Design and Construction Magazine*, September 2002.)

The structural integrity of a concrete or masonry wall is maintained far beyond the time indicated by its fire rating. Structural integrity is critical to the safe evacuation of occupants, and critical in maintaining access for fire fighters and equipment. A catastrophic collapse like that at the World Trade Center might be avoided with a structure of concrete and masonry and, even in a steel frame building, egress stairs can remain traversible for occupants and fire fighters if they are not built of gypsum board.

There are other discrepancies in standard fire tests which also affect the accuracy and credibility of the results. Furnace temperatures must be maintained at certain levels according to the elapsed time. As a result, the amount of fuel required for the test fire depends to some extent on properties of the test specimen. If the specimen itself burns, as it does in wood frame construction, it contributes to furnace temperature and reduces the amount of fuel needed to sustain the time-temperature curve conditions (see Fig. 8-10). In real fires, this means that combustible assemblies add to the fuel and therefore increase the intensity of the fire. If, on the other hand, the test specimen absorbs and stores heat from the furnace, as is the case with concrete and masonry, more fuel is required to maintain the test conditions. Although



(Federal Emergency Management Agency graph from "Fire Safety in Buildings," NCARB Continuing Education Monograph.)

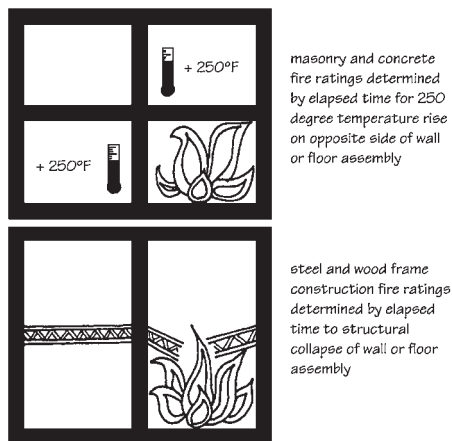
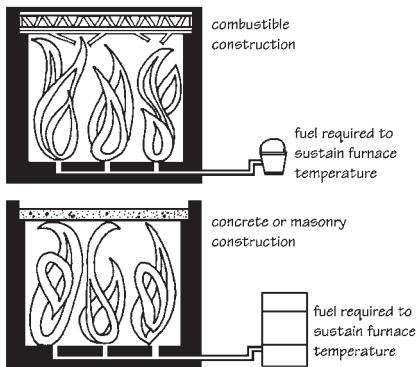


Figure 8-9 Structural collapse and 250°F temperature rise are not comparable criteria in determining fire endurance ratings. (From Portland Cement Association, Fire Protection Planning Reports.)

these variations in fuel consumption during the test would seem to give some indication of the relative fire endurance of the construction, they are not a recognized factor in assigning ratings.

In real building fires, heat and gas movements create positive pressures, especially in the immediate vicinity of the heat source. However, fire test standards do not specify whether the test furnace should be operated with negative or positive pressure. In the United States and Canada, almost all tests are conducted with unrealistic negative pressures, in order to prevent the escape of hazardous gases into the laboratory. In Europe, however, furnaces

COMBUSTIBLE MATERIALS
CONTRIBUTE FUEL TO THE
FIRE



NEGATIVE FURNACE
PRESSURE PRODUCES
UNREALISTIC FIRE RATINGS

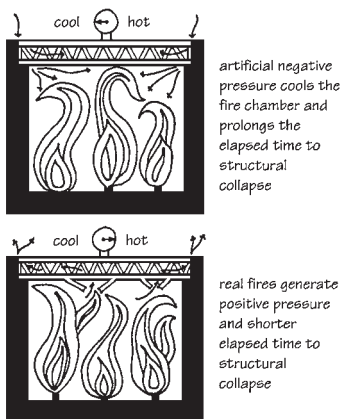


Figure 8-10 Fuel contribution and furnace pressure in U.S. fire tests. (From *Portland Cement Association, Fire Protection Planning Reports*.)

are required to operate with positive pressure and are fitted with safety devices which force emissions out an exhaust flue. Negative pressures tend to draw cool air into the furnace through cracks and gaps that typically exist in wood frame/gypsum board construction, thus extending the endurance time of the assembly beyond what it might be in an actual fire (see *Fig. 8-10*).

Because of the way fire endurance is tested in this country, and the way in which fire ratings are assigned based on these tests, the ratings for concrete and masonry walls are too low, and the ratings for “protected” steel and wood frame assemblies are too high. Concrete or masonry construction controls or prevents substantial fire development because it does not contribute fuel to the fire and, in fact, can actually reduce the intensity of the fire by absorbing and storing heat. Concrete or masonry construction also provides true containment: it will not support fire in concealed spaces of wall, floor, or roof assemblies; it maintains the structural integrity of the building to provide safe access and egress; and it does not produce toxic gases or contribute to smoke generation. Concrete or masonry construction, however, is underrated because of the evaluation system we use. The *ultimate* fire endurance periods for brick walls listed in Fig. 8-11 are as much as three times the maximum ratings given in building codes. Although it is not logical to give the same fire rating to one wall that suffers structural collapse as to another that experiences only a moderate rise in temperature, doing so perpetuates the misconception of the relative safety of various types of construction. The *World Trade Center Building Performance Study* issued jointly by FEMA and ASCE in May 2002 found that current fire resistance test and rating methods do not provide sufficient information on steel and drywall systems to predict actual performance in a fire.

8.4.2 Fire Resistance Ratings

Extensive fire testing has been done on masonry walls, and ratings were first listed in the National Bureau of Standards report BMS 92. Masonry fire ratings are also listed by the National Fire Protection Association in the *Fire Protection Handbook*, by the Underwriters’ Laboratories in its *Fire Resistance Index*, and by the American Insurance Association in *Fire Resistance Ratings*. Model building codes list fire ratings taken from these reports or, in some instances, refer directly to the publications as reference standards. Code tables list the minimum thickness of a particular material or combination of materials required for ratings of 1, 2, 3, and 4 hours. The tables in Figs. 8-12 through 8-15 list fire resistance ratings for clay and concrete

Ultimate Fire Resistance (hours)						
Nominal Wall Thickness (in.)	Wall Type	Noncombustible Members Framed Into Wall or No Framed-In Members			Combustible Members Framed Into Wall	
		No Plaster	Plaster on One Side [‡]	Plaster on Two Sides [‡]	No Plaster	Plaster on Fire Exposed Sides [‡]
4	solid	1-1/4	1-3/4	2-1/2	—	—
8	solid	5	6	7	2	2-1/2
12	solid [†]	10	10	12	8	9
12	solid [†]	12	13	15	—	—
9 to 10	cavity	5	6	7	2	2-1/2

[‡] Minimum 1/2 in. plaster thickness of 1:3 gypsum sand plaster mix.

[†] For loadbearing walls, end point based on load failure.

[‡] For non-loadbearing walls, end point based on temperature rise.

Figure 8-11 Ultimate fire resistance periods for brick walls. (From BIA Technical Note 16 Rev.)

Material Type	Minimum Wall Thickness (inches) for Fire Resistance Rating of ^{a†}			
	1-hr.	2-hr.	3-hr.	4-hr.
Solid brick of clay or shale [‡]	2.7	3.8	4.9	6.0
Hollow brick or tile of clay or shale, unfilled	2.3	3.4	4.3	5.0
Hollow brick or tile of clay or shale, grouted or filled with sand, pea gravel, crushed stone, slag, pumice, scoria, expanded clay, shale or fly ash, cinders, perlite, or vermiculite	3.0	4.4	5.5	6.6

^a Equivalent thickness determined by the formula

$$T_e = V_n/LH$$

where:

T_e = equivalent thickness of the clay masonry unit (inches)

V_n = net volume of the clay masonry unit (inch³)

L = specified length of clay masonry unit (inches)

H = specified height of clay masonry unit (inches)

[†] Calculated fire resistance between hourly increments listed may be determined by linear interpolation.

[‡] Where combustible members are framed into the wall, the thickness of solid material between the end of each member and the opposite face of the wall, or between members set in from opposite sides, shall be not less than 93% of the thickness shown.

[‡] For units in which the net cross-sectional area of cored brick in any plane parallel to the surface containing the cores is at least 75% of the gross cross-sectional area measured in the same plane.

Figure 8-12 Fire resistance of loadbearing and non-loadbearing clay masonry walls. (From International Building Code 2003.)

	Fire Resistance Rating			
	1-hr.	2-hr.	3-hr.	4-hr.
Minimum column dimension (inches)	8	10	12	14

Figure 8-13 Fire resistance of clay masonry columns. (From International Building Code 2003.)

masonry walls and columns from the *International Building Code* (IBC). Ratings for brick and clay tile walls are a function of wall mass or thickness, and depend to some extent on the percent of cored area in the individual units. Units with less than 25% cored area are considered solid, and units with more than 25% cored area are classified as hollow. An 8-in. hollow tile wall contains less mass than an 8-in. solid brick wall, and it therefore offers less resistance to fire and heat transmission. For walls of a given material and design, National Bureau of Standards (NBS) testing showed that an increase of 50% in volume of solid material per unit area of wall surface resulted in a 100% increase in the fire resistance period. Although many fire tests on hollow clay masonry have been conducted, it would be impractical to test all of the possible combinations of unit size, shape, and core area. For walls made up of combinations of masonry units or masonry units and plaster for which there is no listed rating, fire resistance can also be calculated based

Type of Aggregate	Fire Resistance Rating (hours)															
	½	¾	1	1¼	1½	1¾	2	2¼	2½	2¾	3	3¼	3½	3¾	4	
Pumice or expanded slag	1.5	1.9	2.1	2.5	2.7	3.0	3.2	3.4	3.6	3.8	4.0	4.2	4.4	4.5	4.7	
Expanded shale, clay, or slate	1.8	2.2	2.6	2.9	3.3	3.4	3.6	3.8	4.0	4.2	4.4	4.6	4.8	4.9	5.1	
Limestone, cinders, or unexpanded slag	1.9	2.3	2.7	3.1	3.4	3.7	4.0	4.3	4.5	4.8	5.0	5.2	5.5	5.7	5.9	
Calcareous or siliceous gravel	2.0	2.4	2.8	3.2	3.6	3.9	4.2	4.5	4.8	5.0	5.3	5.5	5.8	6.0	6.2	

Notes:

- Values between those shown in the table may be determined by direct interpolation.
- Where combustible members are framed into the wall, the thickness of solid material between the ends of each member and the opposite face of the wall, or between members set in from opposite sides, shall not be less than 93% of the thickness shown.
- Minimum required equivalent thickness corresponding to the hourly fire resistance rating for units with a combination of aggregates shall be determined by linear interpolation based on the percent by volume of each aggregate used in manufacture.

Figure 8-14 Fire resistance of loadbearing and non-loadbearing concrete masonry walls. (From International Building Code 2003.)

	Fire Resistance Rating			
	1-hr.	2-hr.	3-hr.	4-hr.
Minimum column dimension (inches)	8	10	12	14

Figure 8-15 Fire resistance of concrete masonry columns. (From International Building Code 2003.)

on the equivalent solid thickness E_T of the units and the known fire resistance characteristics of the materials. Code requirements such as those in the IBC are based on a minimum required equivalent thickness for each rating. Equivalent solid thickness is the average thickness of solid material in the wall or unit, and is calculated from the actual thickness and the percentage of solid material in the unit. E_T is found by taking the total volume of a wall unit, subtracting the volume of core or cell spaces, and dividing by the area of the exposed face of the unit, using the equation

$$E_T = \frac{V}{l \times h} \quad (8.1)$$

where E_T = equivalent thickness, in.

V = net volume (gross volume less void area), in³

l = length of unit, in.

h = height of unit, in.²

For example, a nominal 8 × 8 modular face size structural clay tile unit that is 6 in. thick has a gross volume of 7% × 7% × 5% = 327 in³. A void area of 40% leaves a net volume $V = 327 - 131 = 196$ in³. Using equation (8.1), the equivalent thickness can be calculated:

$$E_T = \frac{196}{7.625 \times 7.625} = 3.37 \text{ in.}$$

Volume characteristics and equivalent thickness for some typical concrete masonry units are shown in *Fig. 8-16*. The fire resistance of concrete masonry is a function of both aggregate type and equivalent thickness. Aggregates have a significant effect on fire resistance. Lightweight aggregates such as pumice, expanded slag, clay, or shale offer greater resistance to the transfer of heat in a fire because of their increased air content. Units made with these materials require less thickness to achieve the same fire rating as a heavyweight aggregate unit. The table in *Fig. 8-14* lists aggregate types and equivalent thicknesses which will satisfy specific fire rating requirements.

The fire resistance of units or wall assemblies which have not been tested can be calculated using the equation

$$R = (R_1^{0.59} + R_2^{0.59} + \dots + R_n^{0.59} + A_1 + A_2 + A_n + pl)^{1.7} \quad (8.2)$$

where R = calculated fire resistance of the assembly, hr
 R_1, R_2, R_n = fire rating of the individual wythes, hr
 A_1, A_2, A_n = 0.30 coefficient for each continuous air space of at least ½ in. between wythes
 pl = coefficient for thickness of plaster (see *Fig. 8-17*)

This equation can be used to calculate the resistance of masonry cavity walls, composite walls which combine clay and concrete masonry, and grouted walls. For single-wythe or multi-wythe grouted walls, the grout is considered as one layer of a multi-layered assembly, and is rated based on the equivalent thickness of siliceous aggregate from the table in *Fig. 8-14*. The ratings of the unit or units and the rating of the grout are the values used for R_1, R_2 , and R_3 in the equation, and the air space, if any, is as . For example, a 10-in. cavity wall with 4-in. brick, 2-in. open cavity, and 4-in. brick would be calculated as

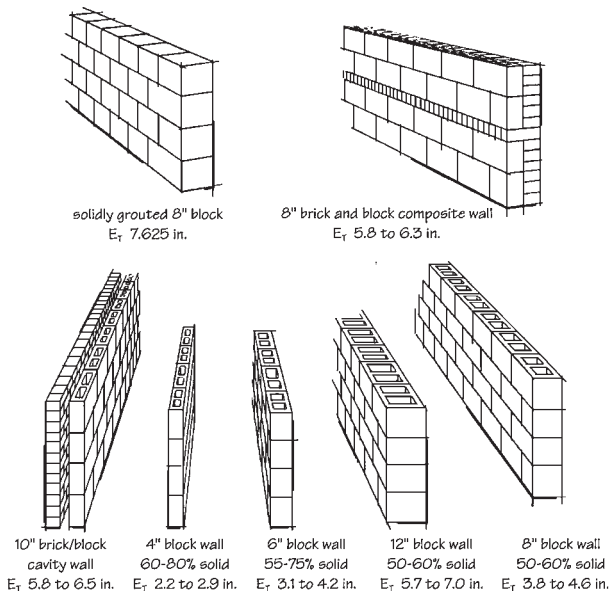
$$R = (1.25^{0.59} + 1.25^{0.59} + 0.30)^{1.7} = 5.01 \text{ hr}$$

A limestone aggregate concrete block with an E_T of 4.2 in. is rated at 2 hours (from *Fig. 8-14*). If the cores of the block are grouted with a sand and gravel aggregate portland cement grout, the E_T of the grout is 7.625 in. - 4.2 in. = 3.4 in. The fire rating for the grout thickness is 1 hour (from *Fig. 8-14*). Therefore,

$$R = (2.0^{0.59} + 1.0^{0.59})^{1.7} = 4.78 \text{ hr}$$

In both instances, the whole is greater than the simple sum of the parts because of the increase in mass per unit of surface area.

The application of plaster to one or both sides of a clay or concrete masonry wall increases the fire rating of the assembly. For portland cement plaster, the plaster thickness may be added to the actual thickness of solid units or to the equivalent thickness of hollow units in determining the rating. For gypsum plaster, a coefficient is added to equation (8.2), $R = (R_1^{0.59} + R_2^{0.59} + \dots + R_n^{0.59} + as + pl)^{1.7}$, where pl is the thickness coefficient of sanded gypsum plaster from *Fig. 8-17*. The methods used for calculating fire resistance are fully described in *Standard Method for Determining Fire Resistance of Concrete and Masonry Assemblies* (ANSI/ACI 216.1/TMS 0216.1).



Width (in.)	Gross Volume (cu.in.)	Minimum Thickness (in.)		Three-Core Units		Two-Core Units	
		Shell	Web	Percent Solid Volume	Equivalent Solid Thickness (in.)	Percent Solid Volume	Equivalent Solid Thickness (in.)
3-5/8	432	0.75	0.75	63	2.28	64	2.32
		1.00	1.00	73	2.66	73	2.66
5-5/8	670	1.00	1.00	59	3.32	57	3.21
		1.12	1.00	63	3.54	61	3.43
		1.25	1.00	66	3.71	64	3.60
		1.37	1.12	70	3.94	68	3.82
7-5/8	908	1.25	1.00	56	4.27	53	4.04
		1.37	1.12	60	4.57	57	4.35
		1.50	1.12	62	4.73	59	4.50
9-5/8	1145	1.25	1.12	53	5.10	48	4.62
		1.37	1.12	55	5.29	51	4.91
		1.50	1.25	58	5.58	54	5.20
11-5/8	1395	1.25	1.12	49	5.70	44	5.12
		1.37	1.12	51	5.93	46	5.35
		1.50	1.25	54	6.28	49	5.70
		1.75	1.25	57	6.63	52	6.04

Figure 8-16 Volume characteristics and equivalent thickness (E_T) of some typical CMUs.

The fire resistance of wall or floor assemblies made up of different materials or types of masonry units can be calculated using the formula

$$R_A = (R_1^{0.59} + R_2^{0.59} + \dots + R_n^{0.59} + A_1 + A_2 + \dots + A_n + pl)^{1.7}$$

Where

R_A	=	fire endurance rating of assembly (hours)
R_1, R_2, \dots, R_n	=	fire endurance rating of assembly components or wythes 1, 2, ..., n, respectively (hours)
A_1, A_2, \dots, A_n	=	0.30 coefficient for each continuous air space of at least 1/2 inch between wythes 1, 2, ..., n, respectively
pl	=	coefficient for thickness of plaster (from table below)

Thickness of Sanded Gypsum Plaster (inch)	Coefficient for Plaster One Side	Coefficient for Plaster Two Sides
1/2	0.30	0.60
5/8	0.37	0.75
3/4	0.45	0.90

Figure 8-17 Calculated fire resistance. (Formula and table from International Building Code 2003.)

8.4.3 UL Ratings

Underwriters' Laboratories (UL) design numbers apply only to a specific proprietary product or assembly manufactured by a specific manufacturer or manufacturers. The fire resistance ratings of clay and concrete masonry, on the other hand, are generic. They apply to all products made from the same types of raw materials. Consequently, UL identifies masonry products by their classification, rather than by design numbers. For example, Class B-4 concrete masonry units have a 4-hour rating, Class C-3 concrete masonry units have a 3-hour rating, and Class D-2 units have a 2-hour rating. The *UL Fire Resistance Directory* then lists CMU manufacturers who are eligible to issue a UL certificate for one or more of these classifications. The Directory also gives UL numbers for several tested masonry wall assemblies. All of these assemblies were tested so that a specific manufacturer could show that a particular product (mortar mix or insulation insert, for example) could be added to or substituted in a "standard" masonry assembly and still achieve the same fire rating.

Most of the masonry wall assemblies "listed" in the UL Directory are too proprietary to apply to masonry construction in general. The UL numbers for these other assemblies are not appropriate if any of the component materials vary from the specific brand or type of products identified, including such items as veneer anchors or lime. For masonry, the more appropriate way to note construction documents is to reference the building code and table from which the rating requirement is taken, and require that unit manufacturers provide test reports or certifications attesting to the fire endurance rating of their products.

8.4.4 Steel Fireproofing

Steel frame construction is vulnerable to fire damage and must be protected from heat and flame. Structural clay tile, brick, and concrete block can all be

used to fireproof steel columns and beams. Hollow structural clay tile units were originally manufactured for this purpose in the late nineteenth century. They offer effective and relatively lightweight protection. Fire test results from the National Bureau of Standards form the basis of modern code requirements for protection of steel structural elements. The table in Fig. 8-18 is taken from the *International Building Code* to show protective masonry coverings that are acceptable for various fire ratings. The FEMA/ASCE *World Trade Center Building Performance Study* noted that on older peripheral buildings around the WTC site, concrete and masonry fireproofing of iron and steel frames “performed well” in both fire endurance and impact resistance, even though it was nearly 100 years old.

8.4.5 Compartmentation

A key element in fire control and balanced fire protection is compartmentation of a building to contain fire and smoke. Codes require that a building be subdivided by fire walls into areas related in size to the danger and severity of fire hazard involved. Fire walls must be constructed of non-combustible materials, have a minimum fire rating of 4 hours, and have sufficient structural stability under fire conditions to allow collapse of construction on either side without collapse of the wall. Masonry fire walls may be designed as continuously reinforced cantilevered sections. They are self-supporting, without depending on connections to adjacent structural framing. For additional lateral stability, free-standing cantilever walls may be stiffened by integral masonry pilasters with vertical reinforcing steel (see Fig. 8-19). Double fire walls can also be used, so that if the building frame on one side collapses,

Minimum Protection of Structural Parts Based on Time Periods for Various Noncombustible Insulating Materials						
Structural Parts to be Protected	Item Number	Insulating Material Used	Minimum Thickness of Insulating Material for the Following Fire-Resistance Periods (Inches)			
			4 Hour	3 Hour	2 Hour	1 Hour
Steel columns and all of primary trusses	1-2.1	Clay or shale brick with and mortar fill	3-3/4			2-1/4
	1-3.1	4" hollow clay tile in two 2" layers; 1/2" mortar between tile and column; 3/8" metal mesh 0.046" wire diameter in horizontal joints; tile fill	4			
	1-3.2	2" hollow clay tile; 3/4" mortar between tile and column; 3/8" metal mesh 0.046" wire diameter in horizontal joints; limestone concrete fill; plastered with 3/4" gypsum plaster	3			
	1-3.3	2" hollow clay tile with outside wire ties 0.08" diameter at each course of tile or 3/8" metal mesh 0.046" diameter wire in horizontal joints; limestone or trap-rock concrete fill extending 1" outside column on all sides			3	
	1-3.4	2" hollow clay tile with outside wire ties 0.08" diameter at each course of tile with or without concrete fill; 3/4" mortar between column and tile				2

Figure 8-18 Masonry fire protection for steel columns. (From International Building Code 2003.)

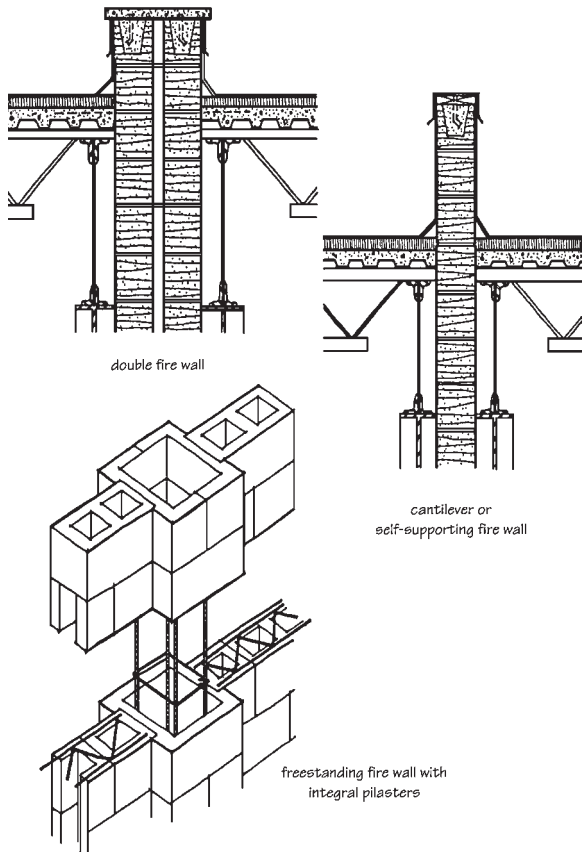


Figure 8-19 Concrete masonry fire walls. (From *National Concrete Masonry Association, TEK Bulletin 95, NCMA, Herndon, VA.*)

half the wall can be pulled over while the other half still protects adjacent areas. Masonry walls also provide a barrier against the spread of smoke and toxic gases.

Fire walls are not used extensively in low-rise multi-family units. Low-rise multi-family buildings (apartments, nursing homes, motels, condomini-

ums) are constructed to essentially the same fire safety standards as single-family dwellings, despite the significantly increased risk posed by the proximity of adjacent units and the vulnerability of occupants to the actions of their neighbors. Code requirements are much less stringent for two- and three-story residential occupancies than for high-rise buildings, and fires can quickly consume several adjacent units of combustible construction. Multifamily dwellings are all too frequently built of wood frame and gypsum board to achieve only a "1-hour" rating. This can be provided by simple 2×4 studs, 16 in. on center, with one layer of $\frac{5}{8}$ -in. Type X gypsum board on each side of the wall. A "2-hour" rating is achieved with a double layer of Type X gypsum board on each side. Townhouse and zero-lot-line developments, however, are often required to have 2-hour *non-combustible masonry* fire walls separating units, and as a result, statistics show that fire losses are greatly reduced.

8.4.6 Fire Insurance Rates

There is one source to which we can look for a realistic comparison of combustible and non-combustible construction, and that is fire insurance rates. The insurance industry must literally guarantee the fire safety of buildings, and they do so for a price that is based on actual fire loss experience and the corresponding degree of risk presented by various types of construction. Studies show that, throughout the United States, insurance premiums for wood frame apartments may be five to ten times higher than for the same apartments built of 2-hour non-combustible masonry walls with concrete floor and roof slabs.

The superior performance of concrete and masonry is recognized by the insurance industry, and putting discrepancies in test results and ratings aside, this is perhaps the best indicator of just how unequal drywall and masonry construction are.

8.5 THERMAL PROPERTIES

The thermal efficiency of a building material is normally judged by its resistance to heat flow. A material's *R value* is a measure of this resistance taken under laboratory conditions with a constant temperature differential from one side to the other. This is called a *steady-state* or *static condition*.

Thermal resistance depends on the density of the material. By this measure, masonry is a poor insulator. Urethane insulation, on the other hand, has a very high resistance because it incorporates closed cells or air pockets to inhibit heat transfer. The reciprocal of the *R value* is the *U value*, or the overall coefficient of heat transmission. Both values are derived from the inherent thermal *conductance* of the material, and its *conductivity* per inch of thickness.

Materials in which heat flow is identical in all directions are considered thermally homogeneous. Materials that are not isotropic with respect to heat transmission (such as hollow masonry units) are considered thermally heterogeneous. Thermal conductance and thermal resistance of homogeneous materials of any thickness can be calculated from the equations

$$C_x = \frac{k}{x} \quad (8.3)$$

and

$$R_x = \frac{x}{k} \quad (8.4)$$

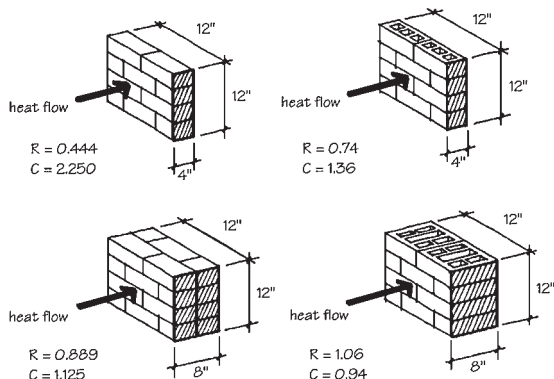


Figure 8-20 Thermal transmittance through masonry walls. (From BIA Technical Note 4 Rev.)

where C = thermal conductance, $\text{Btu}/(\text{hr} \times ^\circ\text{F} \times \text{ft}^2)$

R = thermal resistance, $(\text{hr} \times ^\circ\text{F} \times \text{ft}^2)/(\text{Btu} \times \text{in.})$

k = thermal conductivity, $(\text{Btu} \times \text{in.})/(\text{hr} \times ^\circ\text{F} \times \text{ft}^2)$

x = thickness of material, in.

Figure 8-20 shows the difference between thermal resistance (R) and thermal conductance (C) for thermally homogeneous and thermally heterogeneous masonry walls.

Whenever an opaque wall assembly is analyzed, it should include both the inside and outside air surfaces, which affect both convection and conduction of heat. The inclusion of these air surfaces makes all opaque wall assemblies “layered” construction. In computing the heat transmission coefficients of layered construction, the paths of heat flow must first be determined. If the heat flow paths are in series, the thermal resistances (R) of the layers are additive, but if the paths are in parallel, then the thermal transmittances (U) are averaged. For layered construction with paths of heat flow in series, the total thermal resistance (R) of the wall is obtained by adding the thermal resistances of each layer ($R = R_1 + R_2 + \dots + R_n$), and the overall coefficient of heat transmission is $U = 1/R$. Average transmittances for parallel paths of heat flow are obtained using the equation

$$U_{\text{avg}} = \frac{A_A(U_A) + A_B(U_B) + \dots + A_n(U_n)}{A_t} \quad (8.5)$$

or

$$U_{\text{avg}} = \frac{[1/(R_A/A_A) + 1/(R_B/A_B) + \dots + 1/(R_n/A_n)]}{A_t} \quad (8.6)$$

where A_A, A_B , etc. = area of heat flow path, ft²

U_A, U_B , etc. = transmission coefficients of the respective paths

R_A, R_B , etc. = thermal resistances of the respective paths

A_T = total area being considered ($A_A + A_B + \dots + A_n$), ft²

Such analyses are especially important when the various paths have significantly different heat flow characteristics, or when the paths involve large percentages of the total wall.

A thermal bridge occurs when a material or object of relatively high thermal conductivity penetrates a material of relatively low thermal conductivity, increasing the rate of heat flow at the penetration or "bridge." Thermal bridges not only reduce energy efficiency, but can cause condensation as well. Thermal bridges may be taken into account in different ways. The wall shown in *Fig. 8-21* has thermal bridges where the wood studs interrupt the layer of insulation. The parallel-path method of calculation is used for such non-metallic bridges, where the path at the stud is path A and the path at the insulation is path B. The calculations show that the average U value for the wall is 6% higher than the U value at the insulation.

The wall shown in *Fig. 8-22* has a thermal bridge at the metal tie. Metallic bridges are considered using the parallel-zone method, where a slightly larger area is assumed to be affected than just the actual area of the metal itself (zone A). The American Society for Heating, Refrigeration and Air Conditioning Engineers (ASHRAE) *Handbook of Fundamentals* prescribes a method for determining the size and shape of each zone. In the case of a metal beam, the surface shape of zone A would be a strip of width W centered on the beam. Since the metal tie in *Fig. 8-22* is of circular wire, zone A is a circle of diameter W , which is calculated from the equation

$$W = m + 2d \quad (8.7)$$

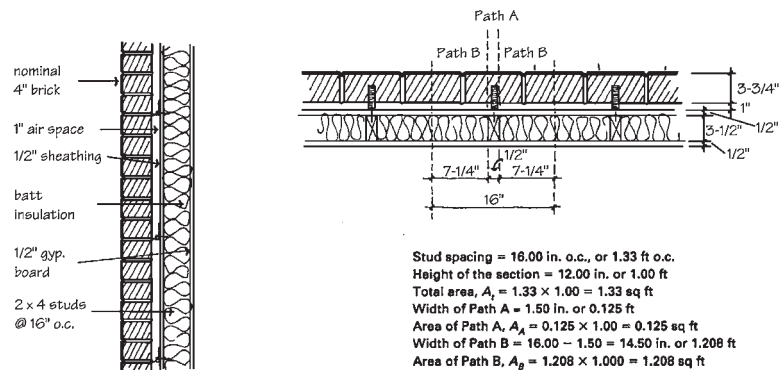
where W = width or diameter of the zone, in.

m = width or diameter of the metal path, in.

d = distance from the panel surface to the metal, in. (but not less than 0.5 in.)

The larger of the two values calculated for W at each surface should be used. *Figure 8-23* shows that the effect of the metal tie is considerably less in an uninsulated cavity wall, because as the R value of the material which the metal bridge penetrates decreases, the percent of heat loss due to thermal bridging also decreases. As the distance between the face of the wall and the edge of the metal increases, however, the area of the affected zone increases. *Figure 8-24* illustrates this phenomenon. Only the web thickness of the metal stud is considered in calculating the area of the zone. The 1 $\frac{3}{8}$ -in. stud flange is relatively thin compared to the wall section, and therefore does not significantly affect the average thermal performance of the system. Its distance from the exterior surface is the thickness of the masonry, plus the air space, plus the sheathing thickness. For quick calculations, the table in *Fig. 8-25* gives effective R values for metal stud walls used as backing for masonry veneers. The closer the stud spacing, the more the thermal bridging affects overall wall performance. With 4-in. studs at 16 in. on center, the wall actually provides only half the thermal resistance that the R value of the insulation indicates.

For estimating a building's heating and cooling requirements, U values are used in heat-loss and heat-gain calculations with specific outdoor design temperatures for winter and summer. These calculations (like the laboratory



Section	C (Btu /(hr · °F · sq ft))	K (Btu · in.) /(hr · °F · sq ft)	x (in.)	C_x (Btu /(hr · °F · sq ft))	Path A $1/C_x$ ((hr · °F · sq ft) /Btu)	Path B $1/C_x$ ((hr · °F · sq ft) /Btu)
Outside air surface	6.000			6.000	0.17	0.17
4-in. nominal face brick		9.000	3.75	2.400	0.42	0.42
1-in. airspace	1.030			1.030	0.97	0.97
Exterior fiberboard sheathing	0.760			0.760	1.32	1.32
2-in. x 4-in. wood stud		0.800	3.50	0.229	4.37	
3½-in. batt insulation						11.00
½-in. gypsum wall-board	2.250			2.250	0.45	0.45
Inside air surface	1.470			1.470	0.68	0.68
					$R_A = 8.38$	$R_B = 15.01$
						$U_B = 0.067$

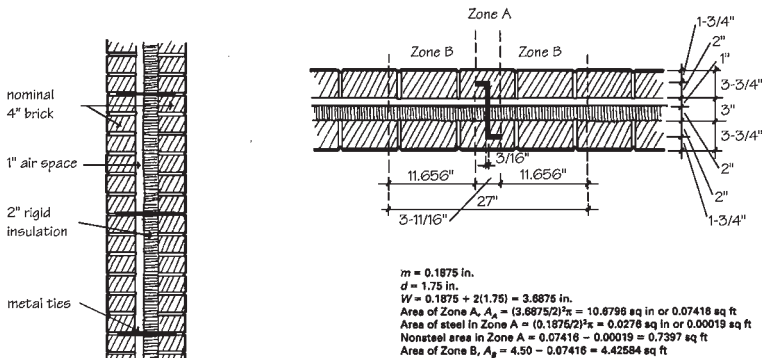
$$R_A/A_A = 67.04 \quad R_B/A_B = 12.43$$

$$1/(R_A/A_A) = 0.015 \quad 1/(R_B/A_B) = 0.080$$

$$U_{avg} = [1/(R_A/A_A) + 1/(R_B/A_B)] / (A_A + A_B) = (0.015 + 0.080) / (0.125 + 1.208) = 0.071 \text{ Btu}/(\text{hr} \cdot \text{ft}^2 \cdot \text{sq ft})$$

$$\frac{U_{avg} - U_a}{U_a} \times 100\% = \frac{0.071 - 0.067}{0.067} \times 100\% = 6.0\%$$

Figure 8-21 Thermal calculations for brick veneer/wood stud wall. (From BIA Technical Note 4 Rev.)



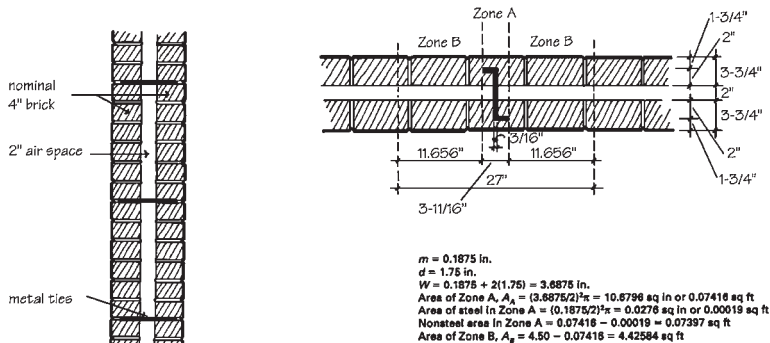
Section	C (Btu /hr*°F*sq ft)	K ((Btu*in.) /hr*°F*sq ft)	x (in.)	C _s (Btu /hr*°F*sq ft)	Zone A			Zone B		
					A (sq ft)	C _s *A (Btu /hr*°F)	$\frac{1}{C_s \cdot A} = \frac{R}{A}$ (/hr*°F) /Btu	A (sq ft)	C _s *A (Btu /hr*°F)	$\frac{1}{C_s \cdot A} = \frac{R}{A}$ (/hr*°F) /Btu
Outside air surface	6.000			6.000	0.07416	0.445	2.25	4.42584	26.555	0.04
4-in. nominal face brick		9.000	3.75	2.400				4.42584	10.822	0.09
Brick		9.000	1.75	5.143	0.07416	0.381	2.62			
Brick		9.000	2.00	4.500	0.07397	0.333				
Steel		314.000	2.00	157.000	0.00019	0.030				
					Subtotal	0.363	2.75			
1-in. airspace	1.030			1.030	0.07397	0.076		4.42584	4.559	0.22
Steel		314.000	1.00	314.000	0.00019	0.060				
					Subtotal	0.136	7.35			
2-in poly-styrene rigid board insulation		0.250	2.00	0.125	0.07397	0.009		4.42584	0.553	1.81
Steel		314.000	2.00	157.000	0.00019	0.030				
					Subtotal	0.039	25.64			
Brick		9.000	2.00	4.500	0.07397	0.333				
Steel		314.000	2.00	157.000	0.00019	0.030				
					Subtotal	0.363	2.75			
Brick		9.000	1.75	5.143	0.07416	0.381	2.62	4.42584	10.822	0.09
4-in. nominal face brick		9.000	3.75	2.400						
Inside air surface	1.470			1.470	0.07416	0.109	9.17	4.42584	6.508	0.15
					$R_1/A_1 = 55.15$ $1/(R_1/A_1) = 0.018$			$R_2/A_2 = 2.40$ $1/(R_2/A_2) = 0.417$		

$$U_{eq} = (1/(R_1/A_1) + 1/(R_2/A_2))/(A_1 + A_2) = (0.018 + 0.417)/(0.07416 + 4.42584) = 0.097 \text{ Btu}/(\text{hr} \cdot \text{F} \cdot \text{sq ft})$$

$$U_B = (1/(R_2/A_2))/A_B = 0.417/4.42584 = 0.094 \text{ Btu}/(\text{hr} \cdot \text{F} \cdot \text{sq ft})$$

$$\frac{U_B - U_2}{U_B} \times 100\% = \frac{0.097 - 0.094}{0.094} \times 100\% = 3.19\%$$

Figure 8-22 Thermal calculations for insulated brick masonry cavity wall. (From BIA Technical Note 4 Rev.)



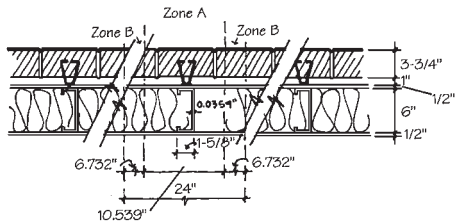
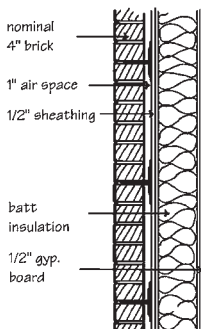
Section	C (Btu /hr·°F·sq ft)	K (Btu·in./ hr·°F·sq ft)	x (in.)	C _s (Btu /hr·°F·sq ft)	Zone A			Zone B		
					A (sq ft)	C _s ·A (Btu /hr·°F)	$\frac{1}{C_s \cdot A} = \frac{R}{A}$ (Btu /hr·°F)	A (sq ft)	C _s ·A (Btu /hr·°F)	$\frac{1}{C_s \cdot A} = \frac{R}{A}$ (Btu /hr·°F)
Outside air surface	8.000			6.000	0.07418	0.448	2.25	4.42584	28.555	0.04
4-in. nominal face brick		9.000	3.75	2.400				4.42584	10.822	0.09
Brick		9.000	1.75	5.143	0.07418	0.381	2.82			
Brick		9.000	2.00	4.500	0.07397	0.333				
Steel		314.000	2.00	157.000	0.00019	0.030				
					Subtotal	0.383	2.75			
2-in. airspace	1.030			1.030	0.07397	0.076		4.42584	4.589	0.22
Steel		314.000	2.00	157.000	0.00019	0.030				
					Subtotal	0.106	9.43			
Brick		9.000	2.00	4.500	0.07397	0.333				
Steel		314.000	2.00	157.000	0.00019	0.030				
					Subtotal	0.383	2.75			
Brick		9.000	1.75	5.143	0.07418	0.381	2.82			
4-in. nominal face brick		9.000	3.75	2.400				4.42584	10.822	0.09
Inside air surface	1.470			1.470	0.07418	0.109	9.17	4.42584	6.506	0.15
					$R_A/A_A = 31.59$ $1/R_A/A_A = 0.032$			$R_B/A_B = 0.59$ $1/R_B/A_B = 1.855$		

$$U_{ins} = [1/(R_A/A_A) + 1/(R_B/A_B)]/(A_A + A_B) = (0.032 + 1.895)/(0.07418 + 4.42584) = 0.384 \text{ Btu}/(\text{hr} \cdot \text{F} \cdot \text{sq ft})$$

$$U_p = [1/(R_p/A_p)]/A_p = 1.895/4.42584 = 0.383 \text{ Btu}/(\text{hr} \cdot \text{F} \cdot \text{sq ft})$$

$$\frac{U_{ins} - U_p}{U_p} \times 100\% = \frac{0.384 - 0.383}{0.383} \times 100\% = 0.26\%$$

Figure 8-23 Thermal calculations for uninsulated brick masonry cavity wall. (From BIA Technical Note 7 Rev.)



$m = 0.0359$ in.
 $d = 3.75 + 1.00 + 0.50 = 5.25$ in.
 $W = 0.0359 \times 2(5.25) = 10.536$ in.
 Area of Zone A, $A_A = 10.536 \times 12.00 = 126.43$ sq in or 0.878 sq ft
 Area of steel in Zone A = $0.0359 \times 12.00 = 0.4308$ sq in or 0.003 sq ft
 Nonsteel area of Zone A = $0.878 - 0.003 = 0.875$ sq ft
 Area of Zone B, $A_B = 2.000 - 0.878 = 1.122$ sq ft

Section	C (Btu /hr·°F·sq ft)	K (Btu·in.) /hr·°F·sq ft)	x (in.)	C _s (Btu /hr·°F·sq ft)	Zone A			Zone B		
					A (sq ft)	C _s ·A (Btu /hr·°F)	$\frac{1}{C_s \cdot A} = \frac{R}{A}$ (hr·°F) /Btu)	A (sq ft)	C _s ·A (Btu /hr·°F)	$\frac{1}{C_s \cdot A} = \frac{R}{A}$ (hr·°F) /Btu)
Outside air surface	6.000			6.000	0.878	5.288	0.19	1.122	6.732	0.15
4-in. nominal face brick		9.000	3.75	2.400	0.878	2.107	0.47	1.122	2.693	0.37
1-in. airspace	1.030			1.030	0.878	0.904	1.11	1.122	1.156	0.87
1/2-in. exterior gypsum sheathing	2.250			2.250	0.878	1.976	0.51	1.122	2.525	0.40
6-in. batt insulation	0.053			0.053	0.875	0.048		1.122	0.059	16.95
Steel		314.000	8.00	52.333	0.003	0.157				
					Subtotal	0.203	4.93			
1/2-in. gypsum wall-board	2.250			2.250	0.878	1.976	0.51	1.122	2.525	0.40
Inside air surface	1.470			1.470	0.878	1.291	0.77	1.122	1.649	0.61
						$R_s/A_s = 8.49$ $1/(R_s/A_s) = 0.118$			$R_b/A_b = 19.75$ $1/(R_b/A_b) = 0.051$	

$$U_{avg} = [1/(R_s/A_s) + 1/(R_b/A_b)]/(A_s + A_b) = (0.118 + 0.051)/(0.878 + 1.122) = 0.085 \text{ Btu}/(\text{hr} \cdot \text{°F} \cdot \text{sq ft})$$

$$U_b = (1/(R_b/A_b))/A_b = 0.051/1.122 = 0.045 \text{ Btu}/(\text{hr} \cdot \text{°F} \cdot \text{sq ft}) \quad \frac{U_{avg} - U_b}{U_b} \times 100\% = \frac{0.085 - 0.045}{0.045} \times 100\% = 88.89\%$$

Figure 8-24 Thermal calculations for brick veneer/metal stud wall. (From BIA Technical Note 7 Rev.)

test conditions) assume a constant temperature differential between outdoor and indoor air, and do not take into account the diurnal cycles of solar radiation and air temperature. As the sun rises and sets each day, the outdoor/indoor temperature differential continually fluctuates. The static conditions on which R and U values are based do not actually exist in the

Metal Stud Walls			
Stud Size (in. x in.) (16-18 gauge C- Channel or Lighter)	Center-to-Center Spacing of Studs (in.)	Cavity Insulation R-Value	Effective Framing/Cavity R-Value
2 x 4	16	11	5.5
2 x 4	16	13	6.0
2 x 4	16	15	6.4
2 x 4	24	11	6.6
2 x 4	24	13	7.2
2 x 4	24	15	7.8
2 x 6	16	19	7.1
2 x 6	16	21	7.4
2 x 6	24	19	8.6
2 x 6	24	21	9.0
2 x 8	16	25	7.8
2 x 8	24	25	9.6

Figure 8-25 Effective R values for metal stud walls used as backing for masonry veneers. (From ASHRAE Standard 90.1, *Energy Efficient Design of New Buildings Except New Low-Rise Residential Buildings*.)

real world. Building materials with heavy mass can react to temperature fluctuations, producing a dynamic thermal response which differs substantially from heat flow calculations based solely on U values. Research indicates that the actual measured rate of heat transfer for masonry walls is 20 to 70% less than steady-state calculation methods predict.

8.5.1 Thermal Inertia

Heat transfer through solid materials is not instantaneous. The time delay involving absorption of the heat is called *thermal lag*. Although most building materials absorb at least some heat, higher density and greater mass cause slower absorption and longer retention. The speed with which a wall will heat up or cool down is described as *thermal inertia*, and is dependent on wall thickness, density, specific heat, and conductivity. It is this phenomenon, in fact, which also contributes to masonry fire safety by delaying heat transfer through the walls of burning buildings.

The thermal storage properties of masonry have been used for centuries. Large, massive central fireplaces were used during the day for heating and cooking. At night, the heat stored in the fireplace shell provided radiant warmth until dawn. In the desert Southwest of the United States, thick adobe masonry walls were used, not so much for strength as for thermal stability. Buildings remained cool during the hot summer days, and heat stored in the walls was later radiated outward to the cooler night air. Until recently, however,

there was no simple way of calculating this response. We now understand that the transmission of heat through building walls is a dynamic process and that any method of calculating heat loss or heat gain that assumes it is static or steady state is not an accurate measure of performance.

Heat flows from hot to cold. As the temperature rises on one side of a wall, heat begins to migrate toward the cooler side. Before heat transfer from one space to another can be achieved, the wall itself must undergo a temperature increase. The amount of thermal energy necessary to produce this increase is directly proportional to the weight of the wall. Masonry is heavy, so it can absorb and store heat and substantially retard its migration. This characteristic is called *thermal storage capacity* or *capacity insulation*. One measure of this storage capacity is the elapsed time required to achieve equilibrium between inside and outside wall surface temperatures. The midday solar radiation load on the south face of a building will not completely penetrate a 12-in. solid masonry wall for approximately 8 hours.

The effects of wall mass on heat transmission are dependent on the magnitude and duration of temperature differentials during the daily cycle. Warm climates with cool nights benefit most. Seasonal and climatic conditions with only small daily temperature differentials tend to diminish the benefits.

Thermal lag and capacity insulation are of considerable importance in calculating heat gain when outside temperature variations are great. During a daily cycle, walls with equal U values but unequal mass will produce significantly different peak loads. The greater the storage capacity, the lower will be the total heat gain. Increased mass reduces actual peak loads in a building, thus requiring smaller cooling equipment. Building envelopes with more thermal storage capacity will also delay the peak load until after the hottest part of the day, when solar radiation through glass areas is diminished and, in commercial buildings, after lighting, equipment, and occupant loads are reduced. This lag time decreases the total demand on cooling equipment by staggering the loads.

Steady-state heat-gain calculations do not recognize the significant benefits of thermal inertia when they employ constant indoor and outdoor design temperatures. Computer studies completed by Francisco Arumi for the Energy Research and Development Administration and the National Concrete Masonry Association (NCMA) made close comparisons between static calculations and dynamic calculations. *Figure 8-26* shows the time-temperature curves derived from each method in calculating inside room temperature.

The attenuation of temperature amplitudes found with the dynamic response calculation graphically illustrates the actual effect that the thermal inertia of massive walls has on indoor comfort. Another study conducted by Mario Catani and Stanley E. Goodwin for the Portland Cement Association (PCA) and reported in the *Journal of the American Concrete Institute* shows heat-gain comparisons for several wall types (see *Fig. 8-27*). Computer analysis using dynamic response methods showed that, when U values were equal, the peak heat gains of the lighter-weight walls were 38 to 65% higher than for the heavy walls. In comparisons of a model building with four alternative wall types, the same results were evident. Using dynamic analysis methods, two heavy concrete walls, a concrete tilt-up wall, and a metal building wall were studied to determine peak cooling loads. Results showed that the heavier walls were far superior in performance to the lightweight sections and that, despite a U value that was 33% higher than the others, the peak loads for one thick concrete wall were 60 to 65% less than those for the lightweight construction.

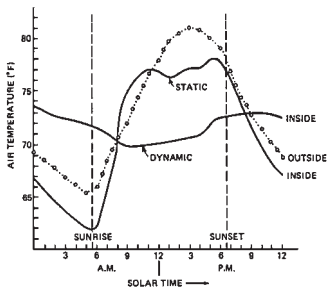


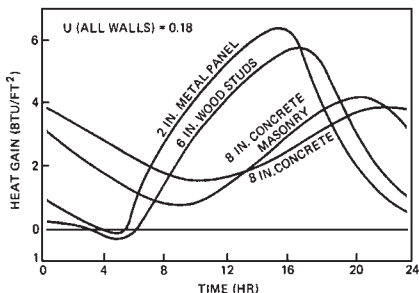
Figure 8-26 Example of static and dynamic thermal calculations for a masonry wall. (From Francisco N. Arumi, *Thermal Inertia in Architectural Walls*, National Concrete Masonry Association, Herndon, VA, 1977.)

NCMA reports other cooling load tests made using NIST computer programs. U values of the walls, roof, and floor were held constant while the wall weight was varied from 10 to 70 lb/sq ft in 5-lb increments. The size of the required air-conditioning equipment varied inversely with the weight of the structure. The lightest-weight walls (10 lb/sq ft) required over 35,000 Btu/hour in air conditioning. The heaviest walls (70 lb/sq ft) required less than 25,000 Btu/hour. When the data is grouped in weight categories matching those of the equivalent temperature difference graph, the relationships are easily compared (see Fig. 8-28).

Heat gain is known to be affected not only by mass and density, but also by surface color and emissivity of the wall, orientation, intensity of direct and diffused solar radiation, and surface reflectivity. Because of these many factors, heat-gain calculations are more complex than simple heat-loss calculations. In any climate where there are large fluctuations in the daily temperature cycle, the thermal inertia of masonry walls can contribute substantially to increased comfort and energy efficiency. The time lag created by delayed heat flow through the walls reduces peak cooling demands to a much greater extent than U values alone indicate.

In northern climates, where heat loss is usually more critical than heat gain, winter temperature cycles more nearly approximate static design conditions because daily temperature fluctuations are smaller. There is still, however, significant advantage to be gained by using masonry walls with thermal inertia. The methods developed by ASHRAE for measuring the dynamic thermal response of heavy construction are more complicated for heat-loss calculations than for heat gain, and require sophisticated computer programs.

The Catani and Goodwin study compared steady-state heat-loss calculations with dynamic analysis. They found that the predicted heat loss based on static conditions was 22% higher than the actual recorded loss for heavy walls, and 8% lower than the actual loss for lightweight walls. Using three different wall types with the same U value, they made a direct comparison of



Average values of heat gain for four walls of a square building show that peak loads are increased from 38 to 65% as result of less mass.

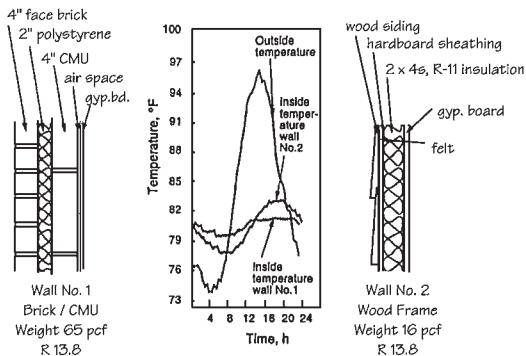


Figure 8-27 Interior temperature comparison and heat-gain curves for various wall types. (From Mario J. Catani and Stanley E. Goodwin, "Heavy Building Envelopes and Dynamic Thermal Response," Journal of the American Concrete Institute, February 1976.)

peak heating loads. It was found that, although the effects are not as dramatic for winter conditions, peak heating load requirements decreased as the weight of the building walls increased (see Fig. 8-29).

Test buildings have been used to validate computer programs for dynamic heat-loss calculations by comparing them to actual measured heating loads. The National Institute of Standards and Technology (NIST) conducted a series of tests on a full-scale building erected in its environmental chamber where both temperature and humidity can be controlled. The study also

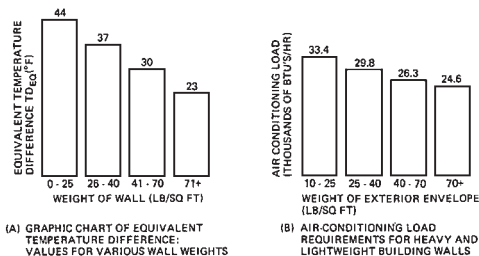
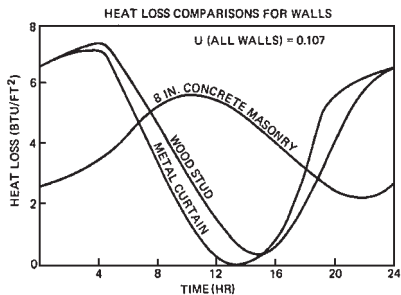


Figure 8-28 Effect of wall weight on heat transfer and air-conditioning load. (From National Concrete Masonry Association, TEK Bulletin 82, NCMA, Herndon, VA.)



A computer program analysis shows that heat loss through walls with identical U-factors and configuration of insulation varies considerably due to mass. The effect of glass, occupants, and lights accentuates the difference.

Figure 8-29 Catani and Goodwin's heat-loss curves for various wall types. (From Mario J. Catani and Stanley E. Goodwin, "Heavy Building Envelopes and Dynamic Thermal Response," Journal of the American Concrete Institute, February 1976.)

compared maximum heat flow rates predicted by the steady-state and dynamic methods with actual measured heat flow (see Fig. 8-30). Steady-state calculations were an average of 52% higher than measured results.

8.5.2 The *M* Factor

The computer programs developed by ASHRAE and NIST for dynamic heat-loss calculations are so complex that they do not easily translate into a simple

Test No.	Insulation	Windows	Maximum Heat Flow Rate (Btu/Hr.)		
			Steady-State Calculation Method	Dynamic Response Calculation Method	Measured Heat Flow
1	none	single-glazed	15,135	11,558	11,372
2	inside	single-glazed	4,470	2,814	2,748
3	outside	single-glazed	4,748	3,047	2,811
4	outside	double-glazed	4,499	2,525	2,700
5 [§]	outside	double-glazed	8,150	6,144	6,321

[§] Range of temperature limits increased.

Figure 8-30 Test results of measured heat flow compared to steady-state and dynamic response calculation methods. (From *National Concrete Masonry Association*, TEK Bulletin 58, NCMA, Herndon, VA.)

equation. Researchers recognized the need for a simpler method of hand calculation that would make the concept of thermal inertia more readily usable. In response to this need, the Masonry Industry Committee sponsored a study by the engineering firm of Hankins and Anderson that resulted in development of the M factor, a simplified correction factor expressing the effects of mass on heat flow.

The M factor is not a new calculation procedure, but is simply used to modify steady-state calculations to account for the effect of wall mass. The M factor is a dimensionless correction factor. It is not a direct measure of the thermal storage capacity of walls. It is defined as the ratio of the cooling or heating load calculated by dynamic response methods to that computed with standard ASHRAE calculation methods.

The modifiers were plotted on a graph with variables of wall weight and number of degree-days (see Fig. 8-31). When the wall weight is very light, and in areas where the number of degree-days is high (colder climates), the M factors approach 1.0 (no correction). Ambient conditions in cold climates more closely approximate a steady-state condition and the traditional U -factor evaluation for heat loss is more accurate than for warmer regions. *The M factors from the curves modify only heat-loss calculations and should not be used in cooling calculations.* The M factor is a simple means of quantifying the effect of thermal inertia on heat-loss calculations without the aid of a computer. It permits a more accurate prediction of dynamic thermal performance than steady-state methods, and is deliberately conservative. In very cold climates, one can give a credit of about 10% to a heavy wall, where the more detailed computer calculations indicate a much greater actual benefit. The results of some computer calculations for various wall weights are shown in Fig. 8-32. The difference between the static and dynamic methods was approximately 20% for the lightweight structure, and about 30% for the heaviest wall. The relationships of heating load to wall weight determined in this and other studies appear to validate the accuracy of the M -factor concept.

8.6 ADDED INSULATION

The thermal performance of masonry walls and their resistance to heat flow can be further improved by adding insulation. In severe winter climates where diurnal temperature cycles are of minimum amplitude, the thermal inertia of brick and block walls can be complemented by the use of resistance insulation such as loose fill or rigid board materials (see Fig. 8-33). Hollow

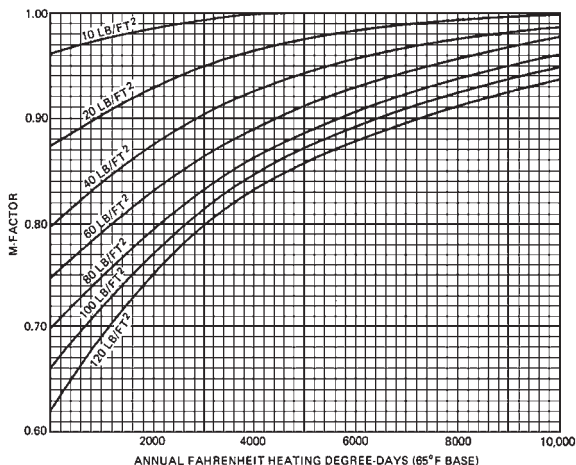


Figure 8-31 Thermal storage capacity correction graph for heat-loss calculations—*M*-factor curves. (From Brick Industry Association, Technical Note 4B, BIA, Reston, VA.)

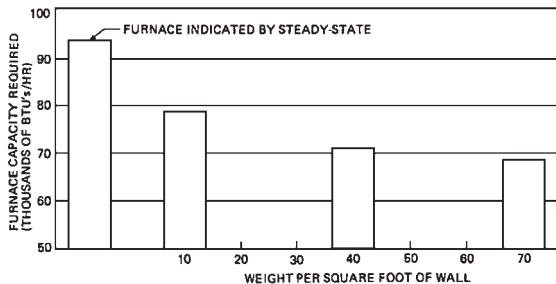


Figure 8-32 Furnace size required for heating load is reduced as weight of wall increases. (From National Concrete Masonry Association, TEK Bulletin 82, NCMA, Herndon, VA.)

units can easily be insulated with loose fill or granular materials, and multiwythe cavity walls and veneer walls over wood or metal frame construction have open cavities for rigid insulating boards (see Fig. 8-34). The proper selection of insulating materials for masonry walls depends on more than just thermal performance.

Material	Density (lb/ft ³)	R-Value per Inch of Thickness	Water Vapor Permeability (perm-in.)	Water Absorption (% by weight)	Dimensional Stability
Molded polystyrene	0.9-1.8	3.6-4.4	1.2-5.0	2-3 [§]	no change
Extruded polystyrene	1.6-3.0	4.0-6.0	0.3-0.9	1-4	no change
Polyurethane, unfaced	1.7-4.0	5.8-6.2	2.0-3.0	negligible	0-12% change
Polyisocyanurate, unfaced	1.7-4.0	5.8-7.8	2.5-3.0	negligible	0-12% change
Perlite, loose fill	5.0-8.0	2.63	100	low	settles 0-10%
Vermiculite, loose fill	4.0-10.0	2.4-3.0	100	none	settles 0-10%

[§] Water absorption given as percent by volume for molded polystyrene only.

Figure 8-33 Properties of insulation materials. (From *Architectural Graphic Standards*, John Wiley, New York.)

- The insulation must not interfere with proper cavity drainage.
- Thermal insulating efficiency must not be impaired by retained moisture from any source (e.g., rain penetration or vapor condensation within the cavity).
- Granular fill materials must be able to support their own weight without settlement, to assure that no portion of the wall is without insulation.
- Insulating materials must be inorganic, or be resistant to rot, fire, and vermin.
- Granular insulating materials must be “pourable” in lifts of at least 4 ft for practical installation.

8.6.1 Granular Fills

Two types of granular fill insulation have been tested by researchers at the Brick Industry Association and found to comply with these criteria: water-repellent-treated *vermiculite* and *perlite* fills.

Vermiculite is an inert, lightweight insulating material made from aluminum silicate expanded into cellular granules about 15 times their original size. Perlite is a white, inert, lightweight granular insulating material made from volcanic siliceous rock expanded up to 20 times its original volume. Specifications for water-repellent-treated vermiculite and perlite are published by the Vermiculite Association and the Perlite Institute, Inc. Each of these specifications contains limits on density, grading, thermal conductivity, and water repellency. Loose fill insulation should not settle more than 0.5% after placement, or a thermal bridge will be created at the top of the wall.

Cavity wall construction permits natural drainage of moisture or condensation. If insulating materials absorb excessive moisture, the cavity can no longer drain effectively, and the insulation acts as a bridge to transfer moisture across the cavity to the interior wythe. Untreated vermiculite and perlite will accumulate moisture, and suffer an accompanying decrease in thermal resistance.

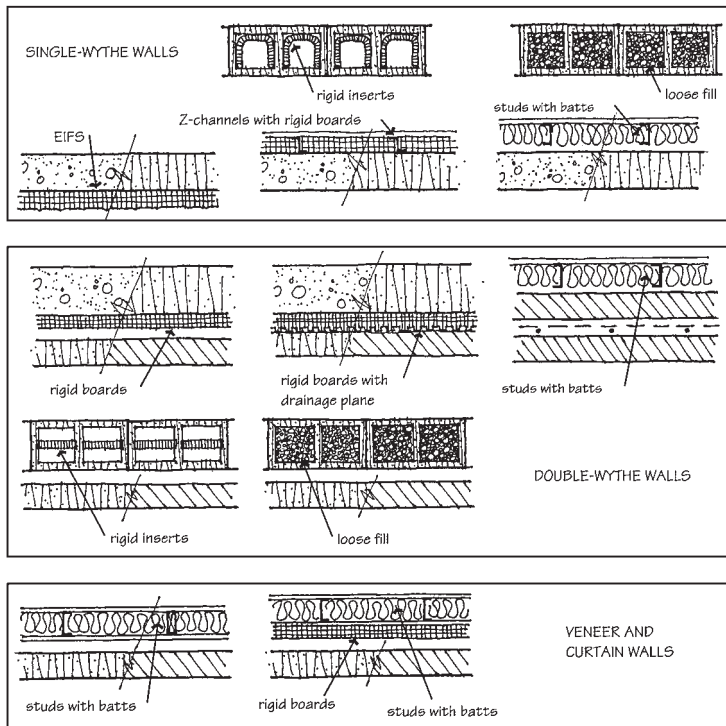


Figure 8-34 Methods of insulating concrete and masonry walls. (Adapted from Beall and Jaffe, *Concrete and Masonry Databook*, McGraw-Hill, New York, 2003.)

Loose fill insulation is usually poured directly into the cavity from the bag or from a hopper placed on top of the wall. Pours can be made at any convenient interval, but the height of any pour should not exceed 20 ft. Rodding or tamping is not necessary and may in fact reduce the thermal resistance of the material. The insulation in the wall should be protected from weather during construction, and weep holes should be screened to prevent the granules from leaking out or from plugging the drainage path.

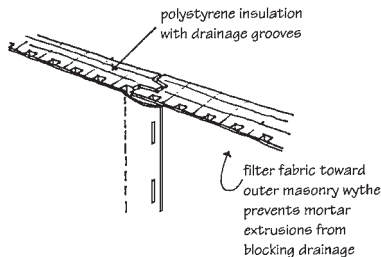
8.6.2 Rigid Board Insulation and Insulation Inserts

Rigid board insulations can be used in masonry cavity and veneer walls. Extruded polystyrene is the most moisture resistant and the most widely used.

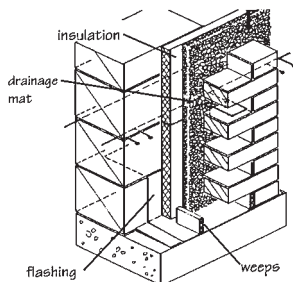
Some proprietary insulation products have drainage mats or drainage grooves designed to prevent mortar extrusions from obstructing the flow of moisture to weep holes (see Fig. 8-35). Air circulation behind the insulation will reduce effectiveness, so rigid insulation should be well adhered or fastened tightly to the backing wall. Gaps between boards will also reduce effectiveness.

Generally, rigid insulation is installed against the cavity face of the backing wall. A minimum of 2 in. should be left between the cavity face of the exterior wythe and the insulation board to facilitate construction and allow for drainage of the cavity. Mechanical and/or adhesive attachment as recommended by the manufacturer is used to hold the insulation in place.

Some concrete block manufacturers produce units with rigid insulation inserts installed at the plant prior to shipment. These inserts may be of polystyrene or polyurethane, and vary in shape and design for different proprietary products (see Fig. 8-36). Hollow unit cores can also be filled with foamed-in-place insulation, but the foam will prevent free drainage of moisture



POLYSTYRENE INSULATION WITH DRAINAGE GROOVES



WOVEN FILAMENT DRAINAGE MAT
ADHERED TO POLYSTYRENE INSULATION

Figure 8-35 Proprietary rigid insulation designed to maintain moisture drainage from masonry wall cavity.

to the weeps in a single-wythe wall. Foamed-in-place, loose fill and most insulation inserts leave thermal bridges at the unit webs because the insulation is not continuous. Thermal bridging in single-wythe walls not only affects heat transfer and energy use, but may cause condensation as well. Lightweight CMU has higher thermal resistance than units made with heavy aggregate, so the effect of thermal bridging is somewhat modified, and the benefits of added insulation somewhat greater (see Fig. 8-37).

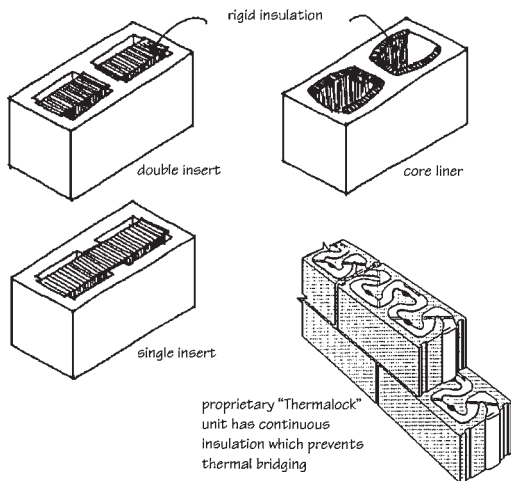


Figure 8-36 Rigid insulation inserts for hollow CMUs.

R-Value of Insulated and Uninsulated Single-Wythe CMU Walls						
Nominal Wall Thickness (in.)	Unit Cores	Concrete Unit Weight				
		60 pcf	80 pcf	100 pcf	120 pcf	140 pcf
4	insulated	3.36	2.79	2.33	1.92	1.14
	uninsulated	2.07	1.68	1.40	1.17	0.77
6	insulated	5.59	4.59	3.72	2.95	1.59
	uninsulated	2.25	1.83	1.53	1.29	0.86
8	insulated	7.46	6.06	4.85	3.79	1.98
	uninsulated	2.30	2.12	1.75	1.46	0.98
10	insulated	9.35	7.45	5.92	4.59	2.35
	uninsulated	3.00	2.40	1.97	1.63	1.08
12	insulated	10.98	8.70	6.80	5.18	2.59
	uninsulated	3.29	2.62	2.14	1.81	1.16

Figure 8-37 Aggregate weight affects thermal resistance of concrete masonry. (From National Concrete Masonry Association, TEK Bulletin 38A, NCMA, Herndon, VA.)

8.6.3 Vapor Retarders and Air Barriers

Under certain conditions of design, it may be necessary to add a vapor retarder or air barrier to an insulated masonry wall to control the flow of water vapor. An acceptable retarder is one with a moisture vapor permeance of less than 1 perm. Vapor retarders and air barriers may be in the form of bituminous materials, foil, or plastic films, or the insulation itself may serve this function. They may be attached to the insulation, or they may be incorporated separately in or on the wall. For maximum effectiveness, air barriers must be continuous and without openings or leaks through which airborne vapor might pass. (See Chapter 9 for additional information regarding moisture control.)

8.6.4 Insulation Location

The most effective thermal use of massive construction materials is to store and reradiate heat, so that insulation location should be based on climatic exposure. *Figure 8-38* shows that the location of the insulation within the

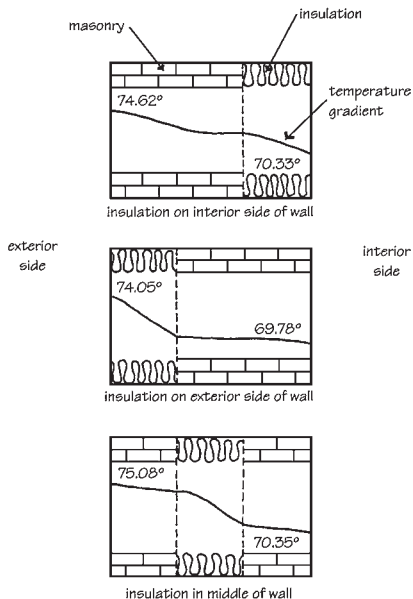


Figure 8-38 Temperature profiles for three different insulation locations. (From Donald Watson, ed., *Energy Conservation through Building Design*, McGraw-Hill, New York, 1979.)

wall section has an effect on heat flux through the wall which is not accounted for by standard U -value calculations. In the thermal research conducted by NIST and NCMA, the effects of variable insulation location were studied. It was found that indoor winter temperature fluctuations were reduced by half when insulation was placed on the outside rather than the inside of the wall, and that the thermal storage capacity of the masonry was maximized. In cavity walls, performance in hot and cold climates is improved if the insulation is placed in the cavity rather than on the inside surface. Insulation location can affect the potential for condensation, so vapor flow as well as heat flow should be considered in optimizing wall performance.

8.7 ENERGY CONSERVATION

Masonry construction can be used in several ways with passive solar design. It can (1) provide a solar screen to shade glass areas on a facade, (2) collect and distribute solar warmth in winter, and (3) intercept excessive heat and solar radiation during the summer. In passive solar design, the buildings themselves collect, store, and distribute heat. A key element is the use of thermal mass—heavy materials which absorb and reradiate large amounts of energy. Passive measures such as cross ventilation, evaporation, exhaustion of hot air by convection, and absorption of heat by thermal mass can provide up to 100% of a building's cooling needs in summer. Masonry is particularly cost effective in these applications because it simultaneously provides supporting structure, spatial definition, acoustical separation, fire separation, finished surfaces, and thermal storage.

Solar energy systems for buildings are divided into two categories: active and passive. Active systems use solar collectors, heat storage tanks, pumps, heat exchangers, and extensive plumbing and electrical controls. Buildings may take any form, and although building orientation is important, it need not be as critical since solar collectors can be oriented for optimum performance regardless of the building's orientation. Passive buildings, on the other hand, *must* be oriented in relation to the seasonal and daily movements of the sun to maximize heat gain in the winter and to minimize solar loads in the summer. Solar heat gain through walls, windows, roofs, skylights, and other building elements can dramatically reduce winter energy requirements. If thermal energy flow is by natural means, such as radiation, conduction, and natural convection, and if solar energy contributes a significant portion of the total heating requirement, the building is considered a passive solar-heated structure.

Thermal mass alone does not constitute passive solar heating or cooling. Buildings must be designed as total systems in order to take advantage of masonry's thermal mass. Using climatic data for each building site, the architect or engineer must determine the optimum amount and location of thermal mass, the type of glass, orientation of windows, and the best use of shading devices, ventilation, daylighting techniques, insulation, landscaping, and efficient heating and cooling equipment. Thermal mass is only one part of passive solar design.

The National Codes and Standards Council of the Concrete and Masonry Industries has published the *Thermal Mass Handbook: Concrete and Masonry Design Provisions Using ASHRAE/IES 90.1-1989*. The handbook is intended to help design professionals take advantage of thermal mass principles in complying with the energy codes. It is an excellent design aid with in-depth coverage that is beyond the scope of this book. The handbook is available through the National Concrete Masonry Association in Herndon, Virginia.

8.7.1 Shading Devices

Solar heat gain through windows can be as much as three times more than heat loss because direct radiation is instantaneously transmitted to the building interior. The incident solar radiation received by a vertical surface often exceeds 200 Btu/hr/ft², and the annual operating cost of cooling equipment attributed to each square foot of ordinary glass is considerable.

The desirability of direct solar heat is evaluated quite differently depending on location, climate, orientation, and time of day. Hot, arid regions generally require exclusion of solar radiation to prevent overheating, excessive air-conditioning loads, glare, or deterioration of materials. In other circumstances, it may be more desirable to ensure adequate sunlight, either for heat or purely for its psychological effect.

If sun control is necessary, the most efficient means is through the use of external shading devices. ASHRAE data indicates that exterior shading devices can reduce the instantaneous rate of heat gain by as much as 85%. Different orientations require different types of shading devices. Horizontal projections or overhangs work best on southerly orientations. Vertical fins are of little value on southern exposures, where the sun is high at midday. For easterly and westerly orientations, however, vertical fins work well. Horizontal elements are of little value here because low morning and afternoon sun altitudes negate their effect. Combination horizontal/vertical egg-crate devices work well on walls facing southeast, and are particularly effective for southwest orientations. Considered by some to give the best "all-around" shading, the egg-crate patterns are most advantageous in hot climates. Their high shading ratio and low winter heat admission, however, can be undesirable in colder regions.

Clay or concrete masonry screens can be assembled in many patterns, with either standard or custom units. Their shading characteristics are all of the egg-crate type (see Fig. 8-39). Masonry screens can be constructed in stack bond, running bond, or split bond (where the individual units are separated horizontally and the wall contains no vertical mortar joints). Standard concrete block or clay tile can be laid with cores perpendicular to the wall surface to create screen effects, or decorative units made expressly for this purpose can be used. Solid brick can be laid in split bond to give open screen patterns of various designs. The overall texture and appearance of the wall is affected by the size and shape of the units as well as the pattern in which they are assembled. Both glazed and unglazed units are available in a variety of colors. Lighter colors provide brighter interior spaces because of greater reflectance. Darker colors reflect less light (see Fig. 8-40). Depending on orientation and latitude, small screen patterns can exclude much or all of the direct sun load.

Glass block has passive solar applications too. In the winter, when the sun is low on the horizon, south-facing glass block panels transmit large amounts of solar energy to the interior. In the summer, when the sun is high overhead, the horizontal and vertical mortar joints form an egg-crate shading device to limit heat gain.

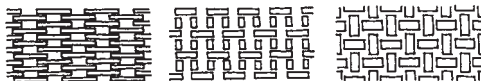
The degree of shading provided by a masonry solar screen is a function of the shape, dimensions, and orientation of the openings. Standard sun path diagrams and shading masks can be used to compute time-shade cycles for openings of any shape, or to custom design a screen for a specific latitude and orientation. Masonry screens can be used to reduce heat gain economically when building orientation cannot be easily adjusted. They can also be retrofitted to existing buildings to substantially reduce air-conditioning loads and lower overall energy consumption.



patterns created using screen tile or screen block



patterns created by turning hollow units on edge



patterns created with solid units and alternating void spaces

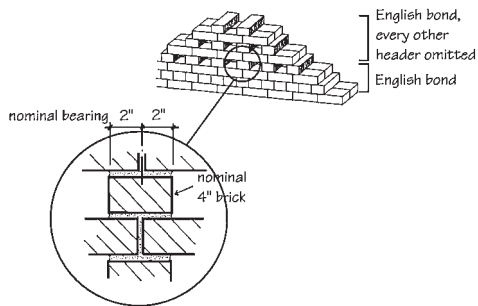


Figure 8-39 Masonry screen wall patterns. (From Brick Industry Association, Technical Notes, Vol. 11, No. 11, BIA, Reston, VA.)

8.7.2 Direct-Gain Solar Heating

The simplest method of solar heating is *direct gain*. If a building is constructed of lightweight materials, solar radiation will heat its low thermal mass quickly and raise inside air temperatures above comfortable levels. At night, these buildings lose their heat just as rapidly, causing temperatures to drop again. Better designs allow sunlight to strike materials of high thermal mass which can store the heat and reradiate it at a later time (see Fig. 8-41). Contemporary materials include poured and precast concrete as well as masonry. When these materials with high heat storage capacity are used for

Reflectance and Absorptance of Clay Brick and Tile (%)		
Material and Color	Reflectance	Absorptance
Unglazed brick and tile		
cream manganese spot	52	48
cream	50	50
light buff	43	57
light gray	40	60
gray manganese spot	40	60
golden buff	35	65
red	30	70
dark red	23	77
Glazed brick and tile		
white	83	17
ivory	67	33
sunlight yellow	65	35
white mottle	64	36
coral	58	42
cream glazed	51	49
light gray	49	51
green mottle	49	51
cream mottle	49	51
light green	46	54
cream tone, salt glaze	44	56
gray mottle	41	59
ocular green	37	63
tan	37	63
blue	35	65
buff tone, salt glaze	27	73
black	5	95

Figure 8-40 Light reflectance and absorptance of glazed and unglazed clay masonry. (From BIA Technical Notes, Vol. 11, No. 11)

walls, floors, and even ceilings, performance and efficiency are increased because the ratio of surface area to volume of mass is maximized.

Masonry walls in direct-gain systems can be any color, but light to medium colors are best for diffusing light over the wall. Heat distribution is generally not critical in direct-gain systems because the heat is stored in the same space in which it is used. The amount of solar heat collected and stored can be controlled by shading devices, and heat loss at night can be minimized by movable insulation. Direct gain is used primarily in mild and moderate climates.

8.7.3 Thermal Storage Walls

In regions with mild to severe winters, a thermal storage wall system provides better performance than direct gain. A loadbearing or non-loadbearing masonry or concrete wall is constructed and, leaving a 2-in. to 4-in. air space, is covered with double insulating glass to act as a collector. The masonry is heated by direct radiation, stores the heat, and then reradiates it to the interior spaces. The glass traps solar energy through a greenhouse effect. Sunlight strikes the mass wall, is converted to thermal energy, and is stored. The storage mass becomes a radiant heat source, and creates natural convection currents which help to distribute the heat. Buildings are most efficient when the glass area and thermal mass are properly sized and oriented for

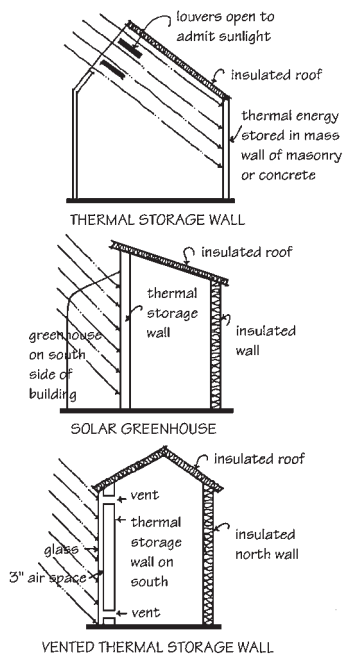


Figure 8-41 Passive solar design strategies using thermal storage walls of masonry or concrete. (From *National Concrete Masonry Association, TEK Bulletin 97, NCM, Herndon, VA.*)

optimum exposure, and are protected from heat loss by movable insulating panels or louvers. Efficiently designed walls may store enough heat to maintain comfortable indoor temperatures for as long as 3 overcast days. Thermal storage wall systems have much less temperature fluctuation than direct-gain systems, but do not usually achieve the same high initial interior temperatures.

8.7.4 Vented Thermal Storage Walls

The most widely used type of thermal storage wall is connected to the interior space by vents at the top and bottom of the wall (see Fig. 8-42). The heated air circulates into the room by thermal buoyancy currents. For summer operation,

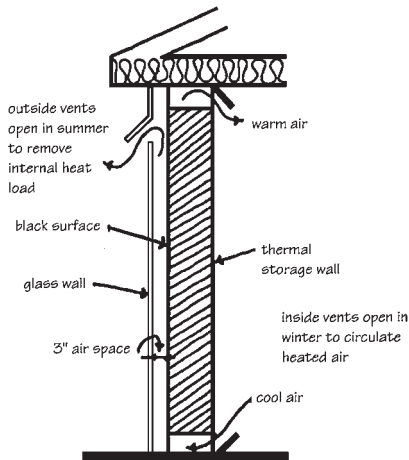


Figure 8-42 Schematic detail of vented thermal storage wall components. (From S. V. Szokolay, *Solar Energy and Building*.)

external vents are opened and the internal vents are closed. Venting the wall to the interior reduces temperature fluctuations and increases the maximum temperature reached in the living space.

The best thermal performance is obtained by combining the direct-gain and thermal storage wall systems. One of the most common applications is a sun room or solarium on the south side of a building. A south-facing wall can also be designed with sections of brick or solid concrete masonry alternating with windows protected from summer radiation by overhangs or shading devices. This combination (1) permits some direct sunlight to enter and warm the interior floor and wall elements, (2) achieves higher interior temperatures than the thermal storage wall alone, (3) provides less temperature fluctuation than the direct-gain system alone, and (4) provides better distribution of natural light.

8.7.5 Hybrid Systems

Fans and blowers can be used in passive solar designs to help the natural flow of thermal energy. These mechanically assisted passive systems are often referred to as hybrid designs. One hybrid design circulates heated air by passing it through the cores of concrete block or 8-in. hollow brick to store and distribute the heat. The primary benefit is that the thermal mass can be located anywhere in the building, regardless of where the heat is collected.

One example is a floor system that uses hollow units placed on their sides with the cores aligned. The solar-heated air is blown through the cores, heating the masonry and the room above. The units should be laid on rigid insulation to prevent heat loss to the soil. Another example is a vertical plenum wall. It passes air through the hollow vertical cores which store heat during the day for later use at night. Sheet metal ducts supply and remove air from the wall.

Hollow-core systems are also effective in cooling. Venting the wall at night by blowing cooler air through the cores lowers the masonry temperature so that it can absorb daytime heat from interior spaces. For commercial buildings which require cooling even in winter because of internal heat generation, outside winter air and the thermal mass of the masonry can be used to cool different zones of the building.

Determining the performance and efficiency of passive solar designs is complex. Computer programs can make the job easier by calculating solar loads, capacity of thermal mass, proper proportions of glass to storage wall areas, heating and cooling requirements, and overall thermal performance. Performance can even be calculated for site-specific weather and solar data. Further analysis can show how combining different energy conservation techniques, passive solar design, and natural cooling strategies can improve total building performance.

8.8 ACOUSTICAL PROPERTIES

Environmental comfort in multi-family housing, hotels, office buildings, and private residences can be related as much to acoustical factors as to heating and cooling. Increased technology produces more and more noise sources at the same time when human perception of the need for privacy and quiet has become acute. Interior noise sources such as furnace fans, television sets, vacuum cleaners, video games, and washing machines combine with exterior street traffic, construction equipment, power mowers, and airplanes to create high levels of obtrusive sound. Noise generated by other people is also very aggravating to residents or tenants who can overhear conversation in adjoining rooms or apartments.

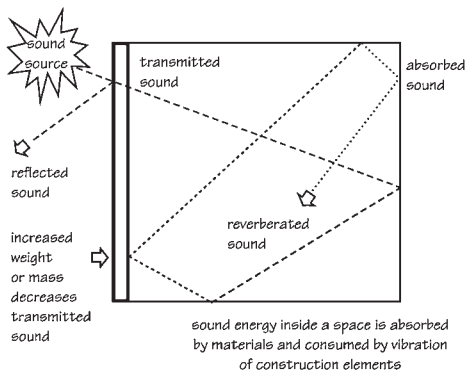
For noise that cannot be either eliminated or reduced, steps can be taken to absorb the sound or prevent its transmission through walls, floors, and ceilings. Some building codes cover acoustical characteristics of construction assemblies. Clay and concrete masonry partitions have been tested and found to provide good sound insulation.

Noise is transmitted in several ways: (1) as airborne sound through open windows or doors, through cracks around doors, windows, water pipes, or conduits, or through ventilating ducts; (2) as airborne sound through walls and partitions; and (3) by vibration of the structure. Acoustical control includes absorbing the sound hitting a wall so that it will not reverberate, and preventing sound transmission through walls into adjoining spaces.

Sound absorption involves reducing the sound emanating from a source within a room by diminishing the sound level and changing its characteristics. Sound is absorbed through dissipation of the sound-wave energy. The extent of control depends on the efficiency of the room surfaces in absorbing rather than reflecting these energy waves. *Sound transmission* deals with sound traveling through barriers from one space into another. To prevent sound transmission, walls must have enough density to stop the energy waves. With insufficient mass, the sound energy will penetrate the wall and be heard beyond it.

8.8.1 Sound Ratings

There are two principal types of sound ratings: absorption and transmission loss. Sound absorption relates to the amount of airborne sound energy absorbed on the wall adjacent to the sound. Sound transmission loss is the total amount of airborne sound lost as it travels through a wall or floor. Each type may be identified at a particular frequency or by class (see Fig. 8-43). Sound absorption coefficients (SACs) and noise reduction coefficients (NRCs) are measured in sabins, sound transmission loss (STL) in decibels. In both instances, the larger the number, the better the sound-insulating quality of the wall.



Type of Rating	Sound Absorption	Sound Transmission
At specific frequencies	Sound Absorption Coefficient (SAC)	Sound Transmission Loss (STL)
Overall performance	Noise Reduction Coefficient (NRC)	Sound Transmission Class (STC)

Sound Absorption Coefficient						
Frequency (cps)	125	250	500	1000	2000	4000
Coefficient (numeric example for ceiling system)	22	62	85	70	65	58

numerical average of Sound Absorption Coefficients (SAC) at middle frequencies
= Noise Reduction Coefficient (NRC)

Figure 8-43 Types of acoustical ratings.

8.8.2 Sound Absorption

Sound is absorbed by mechanically converting it to heat. To absorb sound usefully, a material must have a certain “flow resistance”—it must create a frictional drag on the energy of sound. Sound is absorbed by porous, open-textured materials, and by carpeting, furniture, draperies, or anything else in a room that resists the flow of sound and keeps it from bouncing around. If the room surfaces were capable of absorbing all sound generated within the room, they would have a *sound absorption coefficient* (SAC) of 1.0. If only 50% of it were absorbed, the coefficient would be 0.50.

The percentage of sound absorbed by a material depends not only on its surface characteristics, but also on the frequency of the sound. SAC values for most acoustical materials vary appreciably with sound frequencies. A better measure of sound absorption, which takes frequency variations into account, is the *noise reduction coefficient* (NRC), determined by averaging SAC values at different frequencies. Typical NRC values of various building materials and furnishings are given in *Fig. 8-44*. A higher NRC indicates better sound absorption.

Masonry, wood, steel, and concrete all have low sound absorption, ranging from 2% to 8%. Dense brick and heavyweight concrete block will have 1 to 3%, while lightweight block may be as high as 5%. Painting the surface effectively closes the pores of the material and reduces its absorptive capability even further. Conventional masonry products absorb little sound because of their density and their highly impervious surfaces. Specially designed structural clay tile and concrete block units combine rel-

Material	NRC	Material	NRC
Brick, unglazed	0.04	Concrete floor	0.01
Carpet		Vinyl tile on concrete	0.03
on concrete	0.30	Wood floor	0.08
on pad	0.55	Marble or glazed tile	0.01
CMU, lightweight		Single-strength window glass	0.12
coarse texture	0.40	Plate glass	0.04
medium texture	0.45	Gypsum bd. on 2 x 4 framing	0.07
fine texture	0.50	Gypsum board on concrete	0.03
CMU, normal weight		Plaster or brick on CMU	0.03
coarse texture	0.26	Wood paneling on furring strips	0.13
medium texture	0.27	Draperies	
fine texture	0.28	lightweight	0.14
Deduct for paint		medium weight	0.40
all types, sprayed on		heavy weight	0.55
1 coat	-10%	Furniture	
2 coats	-20%	bed	0.80
oil, brushed on		sofa	0.85
1 coat	-20%	wood table, chairs, etc.	0.20
2 coats	-55%	leather upholstered chair	0.50
latex, brushed on		to cloth upholstered chair	0.70
1 coat	-30%		
2 coats	-55%		
Sound-insulated CMU	0.45		
	0.65		

Figure 8-44 Noise reduction coefficients (NRCs) for various building materials and furnishings. (From BIA Technical Notes, Vol. 9, No. 5.)

atively high sound absorption with low sound transmission characteristics, with little or no sacrifice of strength or fire resistance. Most of these special units have a perforated face shell with the adjacent hollow cores filled with the factory with a fibrous glass pad. Perforations may be circular or slotted, uniform or variable in size, and regular or random in pattern (see Fig. 8-45). Some proprietary units have NRC ratings from 0.45 to as high as 0.85, depending on the area and arrangement of the perforations (see Fig. 8-46).

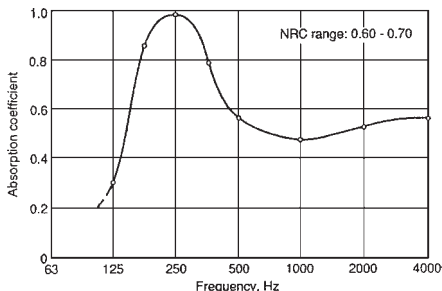
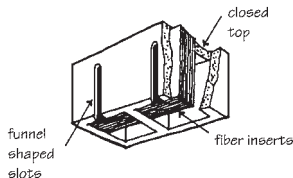
Sound absorption and sound reflection are directly related. If at a given frequency a particular material absorbs 75% of the incident sound, it will reflect the remaining 25%. In acoustical design, sound reflection is just as important as absorption. If too much absorption is provided, or if it is concentrated, the result will tend to “deadened” sound. Too little absorption will cause reverberation, or the persistence of sound within a room after the source has stopped. In excess, this is the principal defect associated with poor acoustics. The optimum reverberation time, which varies with room size and use, can be obtained by controlling the total sound absorption within a room. Alternating areas of reflective and absorptive materials will “liven” sound, promote greater diffusion, and provide better acoustics. Special sound-absorbing masonry units can be alternated with conventional units to achieve this effect.

8.8.3 Sound Transmission

Although it is an important element in control of unwanted noise, sound absorption cannot take the place of sound insulation or the prevention of noise transmission through building elements. The NRC rating ranks wall



Figure 8-45 Acoustical tiles (back row and right) have different face patterns. (Photo courtesy Stark Ceramics, Inc.)



(From Concrete Masonry Handbook, Portland Cement Association)

Figure 8-46 Sound absorption test data for concrete masonry “sound block.”

systems only by sound absorption characteristics and does not give any indication of effectiveness in the control of sound transmission.

Sound energy is transmitted to one side of a wall by air. The impact of the successive sound waves on the wall sets it in motion like a diaphragm. Through this motion, energy is transmitted to the air on the opposite side. The amount of energy transmitted depends on the amplitude of vibration of the wall, which in turn depends on four things: (1) the frequency of the sound striking the surface, (2) the mass of the wall, (3) the stiffness of the wall, and (4) the method by which the edges of the wall are anchored. The *sound transmission loss* (STL) of a wall is a measure of its resistance to the passage of noise or sound from one side to the other. If a sound level of 80 dB is generated on one side and 30 dB is measured on the other, the reduction in sound intensity is 50 dB. The wall therefore has a 50-dB STL rating. The higher the transmission loss of a wall, the better is its performance as a sound barrier.

8.8.4 STC Ratings

Until the early 1960s, the most common sound rating system was the arithmetic average of STL measurements at nine different frequencies. Heavy walls have a relatively uniform STL curve and are satisfactorily classified by

this averaging method. However, lightweight partitions often have “acoustical holes” at critical frequencies (see Fig. 8-47). STL averages did not identify these deficiencies, and did not accurately translate acoustical test results into useful design data. *Sound transmission class* (STC) ratings were developed to describe acoustical characteristics more accurately. STC ratings represent the overall ability of an assembly to insulate against airborne noise. They have proven more reliable in classifying the performance of both heavy- and lightweight materials over a wide range of frequencies. The higher the STC rating a wall has, the better the wall performs as a sound barrier.

For homogeneous walls, resistance to sound transmission increases with unit weight (see Fig. 8-48). When surfaces are impervious, sound is transmitted only through diaphragm action. The greater the inertia or resistance to vibration, the greater is the ability to prevent sound transfer. The initial doubling of weight produces the greatest increase in transmission loss.

Porosity, as measured by air permeability, significantly reduces transmission loss through a wall. STC values vary inversely with porosity. Unpainted, open-textured CMU, for instance, will have lower STC values than would be expected on the basis of unit weight alone. Porosity can be reduced, and STC values increased, by sealing the wall surface. The STC value is increased by about 8% with one layer of gypsum board, 10% with two coats of paint or plaster, and 15% with two layers of gypsum board. Sealing both sides of a wall has little more effect than sealing only one side. A sealed surface not only decreases sound transmission, it also reduces sound absorption, which may not be desirable. As a general rule, leave porous surfaces unsealed in noisy areas such as stairwells or corridors, and seal them in living spaces.

Cavity walls have greater resistance to sound transmission than solid walls of equal weight. Having two wythes separated by an air space interrupts the diaphragm action and improves sound loss. Up to about 24 in., the wider the air space, the more sound efficient the wall will be. Cavity walls are very effective where a high transmission loss, of the order of 70 to 80 dB, is required. If the wythes are only an inch or so apart, the transmission

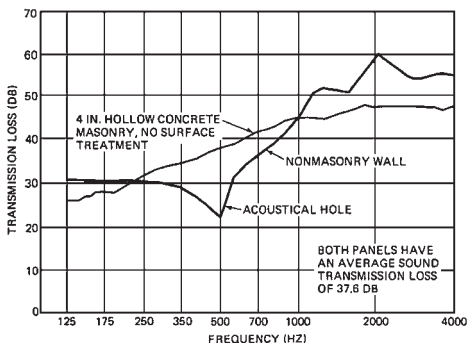
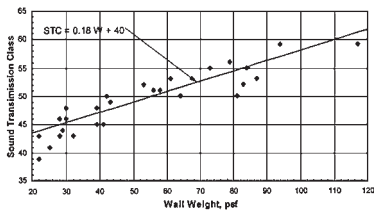


Figure 8-47 Graphic illustration of an “acoustical hole.” (From *National Concrete Masonry Association, TEK Bulletin 9, NCMA, Herndon, VA.*)



(From TMS Standard Method for Determining the Sound Transmission Class Rating for Masonry Walls TMS 0302-00)

Average Weight of Single-Wythe Hollow Unit Masonry Walls (lb/ft²)[§]

	Medium Weight Units 105-125 lb/ft ³ Average 120 lb/ft ³			Normal Weight Units 125 lb/ft ³ or More Average 138 lb/ft ³			Hollow Clay Units	
	Nominal Thickness (inches)						5	8
UngROUTED	6	8	12	6	8	12	5	8
Fully grouted	31	35	50	69	92	140	32	45
Vertical cores grouted at	56	77	118	68	92	140	45	88
16" on center	46	60	90	58	75	111	—	71
24" on center	42	53	79	53	68	99	35	64
32" on center	40	50	73	51	65	93	—	61
40" on center	38	47	70	50	62	89	—	58
48" on center	37	46	68	49	61	87	33	55

[§] Average weight of completed walls of various thickness in pounds per square foot of wall face area. A small quantity has been included for bond beams and reinforcing steel. Grout and mortar made with sand and gravel aggregate.

(From Schneider and Dickey, Reinforced Masonry Design)

Average Weight of Double-Wythe
Grouted and Reinforced Brick Walls[§]

Wall Thickness (inches)	Wall Weight (lb/ft ²)
8	86
8½	93
9	100
9½	106
10	112
10½	118
11	125
11½	131
12	138
13	151
14	164

[§] Based on average brick weight of 10 lb/ft² of vertical surface per inch of thickness and grout core at 13 lb/ft² per inch of thickness.

(From Schneider and Dickey, Reinforced Masonry Design)

Figure 8-48 Sound transmission class (STC) and wall weight.

Nominal Wall Thickness (inches)	Calculated STC Ratings for Clay Masonry Walls ^f							
	Hollow Units		Grout Filled		Sand Filled		Solid Units	
	Weight	STC	Weight	STC	Weight	STC	Weight	STC
3	—	—	—	—	—	—	30	45
4	20	44	38	47	32	46	35	46
6	32	46	63	51	50	49	55	50
8	42	48	86	55	68	52	75	53
10	53	50	109	60	86	55	95	57
12	62	51	132	64	104	59	115	61

^f Based on unit dimension at smaller of specified less manufacturing tolerance; clay density of 120 lb/ft³; grout density of 144 lb/ft³; and sand density of 100 lb/ft³. STC values for grout filled and sand filled units assume the materials completely fill all void areas in and around the units. STC values for solid units are based on bed and head joints solidly filled with mortar.

Figure 8-49 STC ratings for clay masonry walls. (From *The Masonry Society's Standard Method for Determining the Sound Transmission Class Rating for Masonry Walls, TMS 0302-00.*)

loss is less because of the coupling effect of the tightly enclosed air. For maximum benefit, the wythes should be further apart.

Some building codes incorporate standards for sound transmission characteristics in buildings of residential occupancy. The standards generally specify minimum STC ratings for party wall and floor-ceiling separations between dwelling units. Party walls generally require an STC of 45 to 50. STC ratings for brick and block masonry walls are determined based on the standard methodology described in TMS 0302-00, *Standard Method for Determining the Sound Transmission Class for Masonry Walls*. Tabulated values are shown in *Figs. 8-49 through 8-52*.

8.9 MOVEMENT CHARACTERISTICS

All building materials expand and contract to some degree with changes in temperature. Others also expand and contract with variations in moisture content. The thermal movement characteristics of most materials are known, and a standard coefficient can be used to calculate the expected expansion or contraction of a material for a given set of conditions. Masonry materials are relatively stable in thermal movement when compared to metals and plastics.

In addition to thermal movement, however, most masonry materials also experience moisture-related movement. Some shrinking and swelling occur alternately through normal wetting and drying cycles, but more important are the *permanent moisture expansion* of clay masonry and the *permanent moisture shrinkage* of concrete masonry. Clay masonry begins to reabsorb moisture from the atmosphere as soon as the drying and firing process is complete, and as the moisture content increases, the units expand permanently. Concrete masonry products are moist cured to hydrate the portland cement in the mix. Once the curing is complete, residual moisture evaporates, causing the units to shrink permanently.

Calculated STC Ratings for Lightweight Concrete Masonry Walls [§]					
Nominal Wall Thickness (inches)	Density	Hollow Units	Grout Filled	Sand Filled	Solid Units
4	80	43	45	45	45
	85	43	46	45	45
	90	44	46	45	45
	95	44	46	45	45
	100	44	46	45	46
6	80	44	49	47	47
	85	44	49	47	47
	90	44	50	48	48
	95	44	50	48	48
	100	45	50	48	49
8	80	45	53	50	50
	85	45	53	50	50
	90	45	53	50	51
	95	46	53	51	51
	100	46	54	51	52
10	80	46	56	52	52
	85	46	56	53	53
	90	47	57	53	53
	95	47	57	53	54
	100	47	57	54	55
12	80	47	60	55	55
	85	47	60	55	55
	90	48	60	56	56
	95	48	61	56	57
	100	48	61	57	58

[§] Based on grout density of 140 lb/ft³ and sand density of 90 lb/ft³. Percent solid thickness of units based on mold manufacturer's literature for typical units as follows: 4 in = 73.8% solid, 6 in = 55% solid, 8 in = 53% solid, 10 in = 51.7% solid, and 12 in = 48.7% solid. STC values for grout-filled and sand-filled units assume the materials completely fill all void areas in and around the units. STC values for solid units are based on bed and head joints solidly filled with mortar.

Figure 8-50 STC ratings for lightweight concrete masonry walls. (Adapted from *The Masonry Society's Standard Method for Determining the Sound Transmission Class Rating for Masonry Walls, TMS 0302-00.*)

The cumulative effect of reversible thermal movement and irreversible moisture movement must be accommodated in construction through the installation of expansion joints in clay masonry and control joints in concrete masonry. When clay and concrete masonry are combined, or when masonry is combined with or attached to other materials, allowance must also be made for the differential movement of the various components. Expansion, contraction, differential movement, and flexible anchorage are discussed in detail in Chapter 9.

Calculated STC Ratings for Medium Weight Concrete Masonry Walls [§]					
Nominal Wall Thickness (inches)	Density	Hollow Units	Grout Filled	Sand Filled	Solid Units
4	105	44	46	46	46
	110	44	46	46	46
	115	44	47	46	46
	120	45	47	46	47
6	105	45	50	48	49
	110	45	50	49	49
	115	45	51	49	50
	120	45	51	49	50
8	105	46	54	51	52
	110	47	54	52	53
	115	47	55	52	53
	120	47	55	52	54
10	105	48	58	54	55
	110	48	58	54	56
	115	48	58	55	57
	120	49	59	55	57
12	105	49	62	57	59
	110	49	62	57	59
	115	49	62	58	60
	120	50	63	58	61

[§] Based on grout density of 140 lb/ft³ and sand density of 90 lb/ft³. Percent solid thickness of units based on mold manufacturer's literature for typical units as follows: 4 in = 73.8% solid, 6 in = 55% solid, 8 in = 53% solid, 10 in = 51.7% solid, and 12 in = 48.7% solid. STC values for grout-filled and sand-filled units assume the materials completely fill all void areas in and around the units. STC values for solid units are based on bed and head joints solidly filled with mortar.

Figure 8-51 STC ratings for medium weight concrete masonry walls. (Adapted from *The Masonry Society's Standard Method for Determining the Sound Transmission Class Rating for Masonry Walls, TMS 0302-00.*)

Calculated STC Ratings for Normal Weight Concrete Masonry Walls [§]					
Nominal Wall Thickness (inches)	Density	Hollow Units	Grout Filled	Sand Filled	Solid Units
4	125	45	47	46	47
	130	45	47	46	47
	135	45	47	47	47
	140	45	49	47	48
	145	46	48	47	48
	150	46	49	47	48
6	125	46	51	49	51
	130	46	51	49	51
	135	46	52	50	51
	140	46	52	50	52
	145	47	52	50	52
	150	47	52	50	53
8	125	47	55	52	54
	130	48	55	53	55
	135	48	56	53	55
	140	48	56	53	56
	145	49	56	54	56
	150	49	57	54	57
10	125	49	59	56	58
	130	49	60	56	59
	135	50	60	56	59
	140	50	60	57	60
	145	50	61	57	61
	150	51	61	57	61
12	125	50	63	59	62
	130	51	63	59	63
	135	51	64	59	63
	140	51	64	60	64
	145	52	65	60	65
	150	52	65	61	66

[§] Based on grout density of 140 lb/ft³ and sand density of 90 lb/ft³. Percent solid thickness of units based on mold manufacturer's literature for typical units as follows: 4 in = 73.8% solid, 6 in = 55% solid, 8 in = 53% solid, 10 in = 51.7% solid, and 12 in = 48.7% solid. STC values for grout-filled and sand-filled units assume the materials completely fill all void areas in and around the units. STC values for solid units are based on bed and head joints solidly filled with mortar.

Figure 8-52 STC ratings for normal weight concrete masonry walls. (Adapted from *The Masonry Society's Standard Method for Determining the Sound Transmission Class Rating for Masonry Walls, TMS 0302-00.*)

9

MOVEMENT AND MOISTURE CONTROL

Masonry walls are relatively brittle and typically include thousands of linear feet of mortar joints along which cracks and bond line separations can occur. Thermal and moisture movements and dissimilar movements between adjacent materials should always be considered, and components selected and detailed accordingly. Concrete products shrink, clay products expand, and metals expand and contract reversibly. Such movement is accommodated through flexible anchorage and the installation of control joints in concrete masonry and expansion joints in clay masonry. Coefficients of thermal expansion and moisture movement coefficients can be used to estimate the expected movement of various materials, and movement joints sized and located accordingly. If details do not sufficiently accommodate wall movement, excessive moisture can penetrate through the resulting cracks.

9.1 MOVEMENT CHARACTERISTICS

One of the principal causes of cracking in masonry walls is differential movement. All materials expand and contract with temperature changes, but at very different rates. All materials change dimension due to stress, and some develop permanent deformations when subject to sustained loads. Masonry walls are much stronger than in the past because of high-strength units and portland cement mortars, but strength has come at the expense of flexibility. Using masonry as we do today with ductile steel and concrete skeleton frames requires careful consideration of the movement characteristics of each material. Clay masonry expands irreversibly after firing with the absorption of atmospheric moisture. Concrete masonry shrinks irreversibly with the loss of residual moisture from the manufacturing process. Clay masonry expands and concrete masonry shrinks until the units reach an equilibrium moisture content with the environment which surrounds them. Cracking in the masonry can result from restraining the natural expansion or contraction of the materials themselves, or from failure to allow for differential movement of adjoining or connected materials.

9.1.1 Temperature Movement

The thermal movement characteristics of most building materials are known, and a standard coefficient can be used to calculate expected movement for a given set of conditions. The table in *Fig. 9-1* shows that the potential for thermal expansion in masonry is relatively small compared to that of metals.

Average Coefficient of Linear Thermal Movement (T_c)	
Material	T_c (in./in/°F) (multiply by 10^{-6})
Brick	
clay or shale brick	3.6
clay or shale tile	3.3
fire clay brick or tile	2.5
Concrete Masonry	
normal weight	
sand and gravel aggregate	5.2
crushed stone aggregate	5.2
medium weight	
air-cooled slag	4.6
lightweight	
coal cinders	3.1
expanded slag	4.6
expanded shale	4.3
pumice	4.1
Stone	
granite	2.8–6.1
limestone	2.2–6.7
marble	3.7–12.3
sandstone	4.4–6.7
slate	4.4–5.6
travertine	3.3–5.6
Concrete	
calcareous aggregate	5.0
siliceous aggregate	6.0
quartzite aggregate	7.0
Glass	5.0
Metals	
aluminum	13.2
steel, carbon	6.7
steel, stainless	
300 series	8.9–9.6
400 series	5.8–6.1
brass	10.4
bronze	10.0–11.6
copper	9.4–9.8
zinc	
rolled	17.4
alloy, with grain	13.0
alloy, across grain	9.8
Wood	
parallel to fiber	
fir	2.1
maple	3.6
oak	2.7
pine	3.0
perpendicular to fiber	
fir	32.0
maple	27.0
oak	30.0
pine	19.0

Figure 9-1 Coefficients of linear thermal expansion for some building materials.

Coefficients for masonry units vary with the raw material or type of aggregate used. The stress developed in a restrained element due to temperature change is equal to the *modulus of elasticity* \times *coefficient of thermal expansion* \times *mean wall temperature change*. For instance, the tensile stress in a fully restrained block wall with a thermal expansion coefficient of 4.5×10^{-6} and modulus of elasticity of 1.8×10^6 for a temperature change of 100°F is

$$0.0000045 \times 1,800,000 \times 100^\circ\text{F} = 810 \text{ psi}$$

Wall surface temperatures must be used to calculate thermal movement because they represent greater extremes than ambient air temperatures, and therefore predict actual movement more accurately. Vertical wall surface temperatures in winter are usually within a few degrees of ambient (depending on the amount of insulation present in the wall), and may safely be assumed to equal the ASHRAE winter design dry-bulb temperature. Summer surface temperatures, however, are affected by solar radiation, thermal mass, and the temperature gradient through the thickness of the material. One equation used to calculate summer surface temperature taking these factors into consideration is

$$T_s = T_a + (H)(A) \quad (9.1)$$

where T_s = extreme summer surface temperature of wall, $^\circ\text{F}$
 T_a = extreme summer air temperature, $^\circ\text{F}$ (dry bulb)
 H = constant for heat capacity of material (see Fig. 9-2)
 A = solar absorption coefficient of material (see Fig. 9-3)

The total wall surface temperature differential (ΔT) is found by subtracting winter surface temperature from summer surface temperature:

$$\Delta T = T_s - T_w \quad (9.2)$$

where ΔT = total surface temperature differential, $^\circ\text{F}$
 T_s = extreme summer surface temperature of wall, $^\circ\text{F}$ [from equation (9.1)]
 T_w = extreme winter surface temperature, $^\circ\text{F}$ (ASHRAE dry bulb)

The formula given in ASTM C1193, *Standard Guide for Use of Joint Sealants*, can then be used to calculate thermal movement:

$$\Delta L_t = (T_c)(\Delta T)(L) \quad (9.3)$$

where ΔL = dimensional change, in.
 T_c = thermal movement coefficient (see Fig. 9-1)
 ΔT = total surface temperature differential, $^\circ\text{F}$ [from equation (9.2)]
 L = panel length, in.

For example, thermal movement for a clay brick panel with a thermal expansion coefficient of 3.6×10^{-6} (from Fig. 9-1), an estimated surface temperature differential of 145°F , and a panel length or joint spacing of 20 ft is calculated as

$$\Delta L_t = (0.0000036)(145^\circ\text{F})(240 \text{ in.}) = 0.12528 \text{ in.} \quad (\text{or about } \frac{1}{8} \text{ in.})$$

9.1.2 Moisture Movement

Many building materials expand as moisture content increases and then contract when it decreases. In some instances this moisture movement is almost fully reversible, but in others the change in dimension is permanent

Constant for Heat Capacity (H)	
Type of Material	(H)
Low heat capacity materials [§]	100 or 130
Solar radiation reflected on low heat capacity materials [§]	75 or 100
High heat capacity materials [§]	75 or 100
Solar radiation reflected on high heat capacity materials [§]	75 or 100

[§] Materials such as EIFS and well-insulated metal panel curtain walls have low thermal storage capacity. Materials such as concrete and masonry have high thermal storage capacity.

[§] If the wall surface receives reflected as well as direct solar radiation, use the larger coefficient. Reflected radiation may be from adjacent wall surfaces, roofs, and paving.

Figure 9-2 Constant for heat capacity of materials with low thermal storage capacity and high thermal storage capacity. (From ASTM C1472, Standard Guide for Calculating Movement and Other Effects When Establishing Sealant Joint Width. Copyright ASTM, 100 Barr Harbor Drive, West Conshohocken, PA 19428. Reprinted with permission.)

Solar Absorption Coefficient (A)	
Material	A
Aluminum	0.40–0.65
Black, non-metallic (asphalt or slate)	0.85–0.98
Brick, light buff	0.50–0.70
Brick, red	0.65–0.85
Brick, white	0.25–0.50
Concrete, natural	0.65
Copper	0.65–0.80
Galvanized steel	0.40–0.65
Glass, clear, 1/4"	0.15
Glass, tinted, 1/4"	0.48–0.53
Glass, reflective, 1/4"	0.60–0.83
Marble, white	0.58
Paint	
dark red, brown or green	0.65–0.85
black	0.85–0.98
white	0.23–0.49
Surface color	
black	0.95
dark gray	0.80
light gray	0.65
white	0.45
Wood, smooth	0.78

Figure 9-3 Solar absorption coefficient for calculating thermal movement. (From ASTM C1472, Standard Guide for Calculating Movement and Other Effects When Establishing Sealant Joint Width. Copyright ASTM, 100 Barr Harbor Drive, West Conshohocken, PA 19428. Reprinted with permission.)

and irreversible. Permanent moisture shrinkage affects all portland cement-based materials, including concrete, stucco, and concrete masonry. Permanent moisture expansion affects only clay masonry products.

Concrete masonry units shrink irreversibly as they lose the residual moisture from the manufacturing process. They subsequently expand and contract reversibly with changes in moisture content. The total amount of shrinkage varies with water-cement ratio, method of curing, aggregate type and gradation, cement type and content, service exposure, and carbonation. ASTM standards for concrete masonry units previously included a distinction between two types of units, based on moisture content and potential shrinkage. This distinction is no longer made, and the coefficients of linear moisture movement in *Fig. 9-4* for concrete masonry units made with different aggregates apply to all CMUs.

Steel reinforcement increases concrete masonry's resistance to the tensile stress of shrinkage. The most common method of shrinkage crack control is the use of horizontal joint reinforcement, which distributes the stress more evenly through the wall to minimize cracking. Control joints localize cracking to predetermined locations so that elastomeric sealants can be installed in the joint to prevent moisture penetration. Masonry that is reinforced to resist structural loads is also more resistant to shrinkage cracking.

The firing process removes virtually all moisture from clay masonry products. After they leave the kiln, reabsorption of moisture causes irreversible expansion. Total expansion depends primarily on the characteristics of the clay, but also on firing temperatures. For any given clay, the higher the firing temperature, the lower is the potential for expansion. Some minor reversible expansion occurs with subsequent changes in moisture content, but it is the initial permanent expansion in size which most affects building design. The majority of brick moisture expansion occurs during the first year after manufacture, but it continues at a much slower rate for years (see *Fig. 9-5*).

9.1.3 Elastic Deformation

Shortening of axially loaded masonry walls or columns is seldom critical. More often, problems arise from elastic deformation of horizontal masonry elements

Average Coefficient of Linear Moisture Movement (M _c)			
Material	Reversible Moisture Movement (%)	Coefficient (M _c) for Irreversible Moisture Movement (%)	Type of Movement
Concrete, gravel aggregate	0.02–0.06	0.03–0.08	shrinkage
Concrete, limestone aggregate	0.02–0.03	0.03–0.04	shrinkage
Concrete, lightweight aggregate	0.03–0.06	0.03–0.09	shrinkage
Concrete block, dense aggregate	0.02–0.04	0.02–0.06	shrinkage
Concrete block, lightweight aggregate	0.03–0.06	0.02–0.06	shrinkage
Brick, clay face	0.02	0.03–0.08	expansion
Limestone	0.01	unknown	n/a
Sandstone	0.07	unknown	n/a

Figure 9-4 Concrete masonry units shrink irreversibly with initial moisture loss and clay masonry units expand irreversibly with initial moisture absorption. (From *ASTM C1472*, Standard Guide for Calculating Movement and Other Effects When Establishing Sealant Joint Width. Copyright ASTM, 100 Barr Harbor Drive, West Conshohocken, PA 19428. Reprinted with permission.)

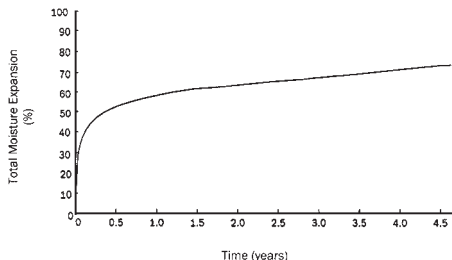


Figure 9-5 Graph showing permanent moisture expansion of clay brick over time. (From BIA Technical Note 18 Rev.)

such as beams and lintels. Standards limit deflection to $L/600$ or 0.3 in. under combined live and dead loads. In veneer construction, deformation of the structural frame to which the masonry is attached can also cause distress if loads are inadvertently transferred to the veneer.

9.1.4 Plastic Flow

When concrete or steel is continuously stressed, there is a gradual yielding of the material, resulting in permanent deformation equal to or greater than the elastic deformation. Under sustained stress this plastic flow, or creep, continues for years, but the rate decreases with time and eventually becomes so small as to be negligible. About one-fourth of the ultimate creep takes place within the first month or so, and one-half of the ultimate creep occurs within the first year. In clay masonry construction, the units themselves are not subject to plastic flow, but the mortar is. In concrete block construction, long-term deformations in the mortar and grout are relatively high compared to that of the unit. Joint reinforcement in CMU construction restrains the mortar and grout so that overall deformations of the wall are similar in magnitude to those for cast-in-place concrete. Plastic flow of the mortar in brick walls helps prevent joint separations by compensating to some degree for the moisture expansion of the units.

The creep deflection of a concrete or steel structural frame to which masonry is rigidly anchored is the most potentially damaging. Steel shelf angles and concrete ledges that sag over a period of time can exert unintended force on the masonry below. Without soft joints below such members, the masonry can buckle or spall under the eccentric load.

9.1.5 Effects of Differential Movement

Differential movement is the primary cause of cracking in masonry walls. In a cavity wall, for example, the moisture exposure and temperature variation in the outer wythe are much greater than in the inner wythe, especially if the wall contains insulation. Cracks can form at the external corners of brick walls because of the greater thermal and moisture expansion of the outer wythe which result. Long walls constructed without expansion joints also



Figure 9-6 Opposing moisture expansion of brick and curing shrinkage of concrete slab can cause cracking at building corners if differential movement is not accommodated.

develop shearing stresses in areas of minimum cross section, so diagonal cracks often occur between window and door openings, usually extending from the head or sill at the jamb of the opening. When masonry walls are built on concrete foundations that extend above grade, thermal and moisture expansion of the masonry can work against the drying shrinkage of the concrete, causing extension of the masonry wall beyond the corner of the foundation or cracking of the foundation (*Fig. 9-6*). The concrete contracts with moisture loss and lower temperatures, the brick expands with moisture absorption, and cracks form near the corners. Flashing at the base of the wall serves as a bond break between the masonry and the foundation and allows independent movement without such damage.

Brick parapet walls can be particularly troublesome because, with two surfaces exposed, they are subject to temperature and moisture extremes. Differential expansion from the building wall below can cause parapets to bow, to crack horizontally at the roof line, and to overhang corners (*Fig. 9-7*). Through-wall flashing, although necessary, creates a plane of weakness at the roof line that may amplify the visual problem, but allows the differential movement to occur without physical damage to the masonry. If parapets are included in a building design, additional expansion joints can accommodate movements in the parapet without excessive sliding at the flashing plane, and without bowing or cracking in the parapet itself. Adding steel reinforcement also helps to counteract the tensile forces created and prevent excessive



Figure 9-7 Parapets can expand and contract at a different rate than the building walls below.

movement. The same material should be used for both wythes of multi-wythe parapets so that the back and front of the wall expand and contract at the same rate.

Floor and roof slabs poured directly on masonry bearing walls can curl from shrinkage, deflection, and plastic flow of the concrete. If the slab warps, it can rupture the masonry at the building corners and cause horizontal cracks just below the slabs. To permit flexibility, a horizontal slip plane should be installed between the slab and wall, running 12 to 15 ft back from the corners and terminating at a movement joint. This will relieve the strain at the points where movement is greatest (see *Fig. 9-8*).

Vertical shortening of concrete structural frames from shrinkage or creep can transfer excessive stress to masonry cladding. Failures are characterized by bowing, by horizontal cracks at shelf angles, by vertical cracks near corners, and by spalling of masonry units at window heads, shelf angles, and other points where stress is concentrated. Horizontal soft joints must be provided to alleviate these stresses and allow the frame to shorten without damage to the masonry (see Chapter 10 for details). Where structural steel columns are protected by masonry, the greater temperature movement of the column can be inadvertently transmitted to the masonry and cause cracking. To prevent this problem, a bond break material should isolate the masonry from the steel to prevent mortar bond, and flexible anchors should be used to accommodate the differential movement.

To avoid problems of cracking and subsequent moisture leakage, differential movement between various types of masonry, and between masonry and other materials, must be accommodated by isolation, by flexible anchorage, and by vertical and horizontal expansion joints.

9.2 FLEXIBLE ANCHORAGE

When masonry walls are connected to steel or concrete frame buildings, differential movement must be accommodated in the anchorage of one material to another. Even if the exterior masonry veneer carries its own weight to the foundation without shelf angles or ledges, the columns or floors provide the lateral support which is required by code. Flexible connections should allow relative vertical movement without inducing stresses which could cause damage (i.e., they should resist the lateral tension and compression of wind loads, but not in-plane shear movements). Various types

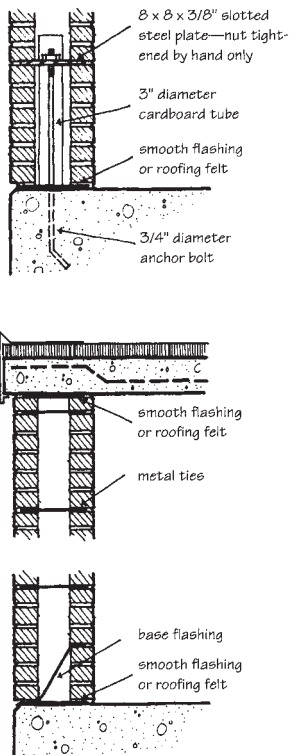


Figure 9-8 Bond breaks in wall-to-floor and wall-to-roof connections. (From Harry C. Plummer, *Brick and Tile Engineering*, Brick Industry Association, Reston, VA, 1962.)

of flexible anchors were discussed in Chapter 7, and *Figs. 9-9 and 9-10* show ways in which they are used. Seismic anchors for the attachment of veneers are designed to meet the requirements for Seismic Performance Categories D and E of the Masonry Standards Joint Committee (MSJC) *Building Code Requirements for Masonry Structures*, ACI 530/ASCE 6/TMS 402 (see Chapter 12).

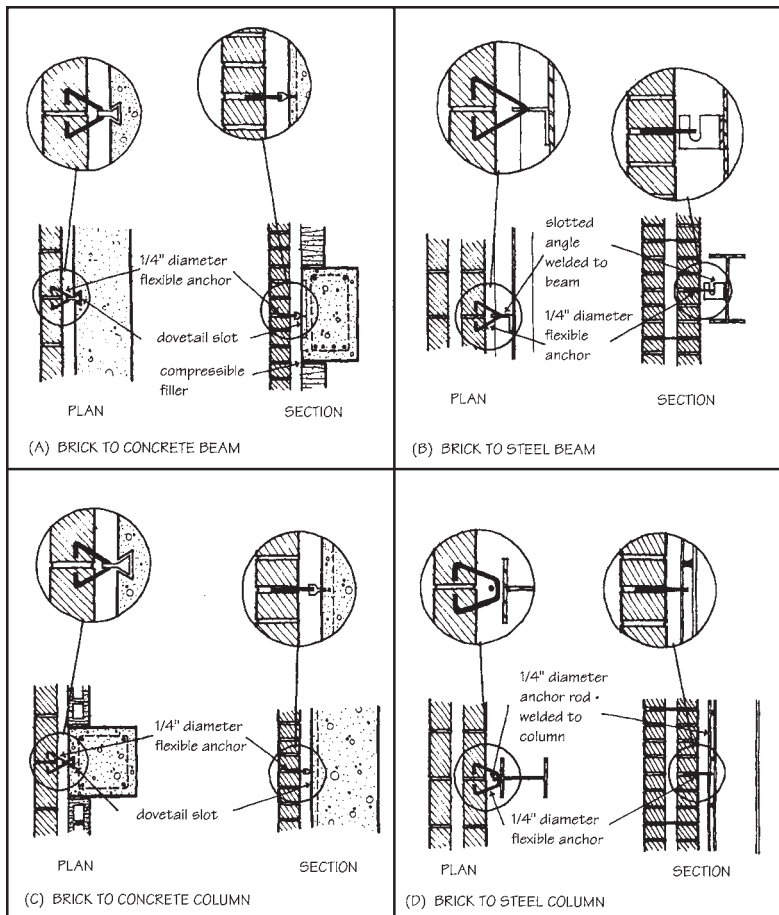


Figure 9-9 Flexible anchorage of brick masonry. (From BIA Technical Note 18.)

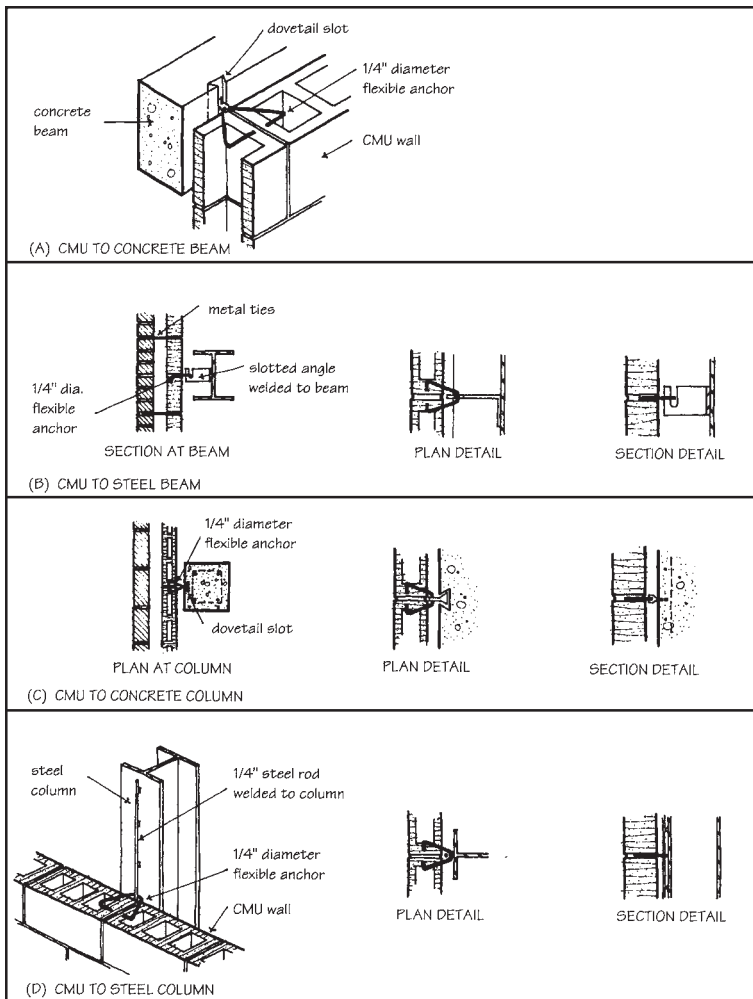
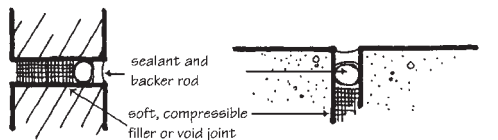


Figure 9-10 Flexible anchorage of concrete masonry.

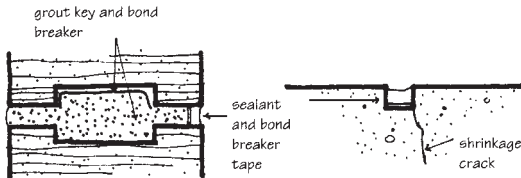
In loadbearing masonry construction the brick or block walls support concrete floor slabs or steel joist and metal deck floors. The methods of anchorage will vary for different conditions (see Chapter 12). With concrete block and concrete slabs, there is less concern about differential movement because of the similarity of the material characteristics. Connections may be either rigid or flexible, depending on the particular design situation. In brick masonry, however, it is more common to provide a bond break or slippage plane at the point where a concrete slab rests on the wall. Roofing felt or flashing is commonly used for this purpose, and allows each element to move independently while still providing the necessary support. The bond break may be detailed for both conditions where wall-to-slab anchorage is or is not required (see Fig. 9-8). Where masonry walls rest on a concrete foundation, mechanical anchorage between the two elements often is not necessary because the weight of the wall and its frictional resistance to sliding are adequate for stability. In shear wall design where floor-wall connections must transfer loads through diaphragm action, anchorage must be designed as part of the engineering analysis (see Chapter 12).

9.3 MOVEMENT JOINTS

In addition to the flexible anchorage of backing and facing materials, control joints and expansion joints are used to alleviate the potential stresses caused by differential movement between materials, and by thermal and moisture movement in the masonry. The terms *control joint* and *expansion joint* are not interchangeable. The two types of joints are different in both function and configuration (see Fig. 9-11).



EXPANSION JOINTS IN MATERIALS, IN WALL SYSTEMS, OR IN BUILDINGS ALLOW FOR BOTH EXPANSION AND CONTRACTION



CONTROL JOINTS IN CONCRETE, STUCCO AND CONCRETE MASONRY CONTROL THE LOCATION OF SHRINKAGE CRACKS
(in concrete work, control joints are sometimes called contraction joints)

Figure 9-11 Expansion joints and control joints are different, and the terms should not be used interchangeably.

9.3.1 Joint Design

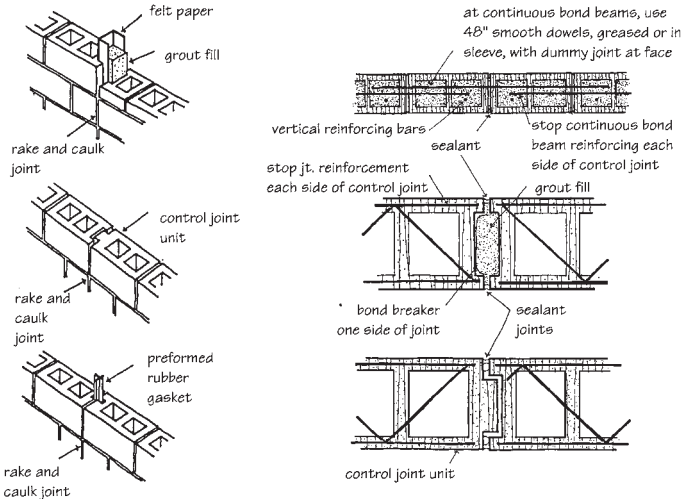
Control joints are continuous, weakened joints designed to accommodate the permanent shrinkage of portland cement-based products such as concrete masonry. When stress development is sufficient to cause cracks, the cracking will occur at these weakened joints rather than at random locations. Although horizontal joint reinforcement can be used to limit shrinkage cracking, strategically located control joints must also be used to eliminate random cracks and prevent the resulting moisture penetration. Cracking is not as likely to occur in fully reinforced construction, since the reinforcing steel absorbs the tensile stress.

Control joints must also provide lateral stability between adjacent wall sections. *Figure 9-12* shows several common types of joints, all of which provide a shear key for this purpose. Control joints must also be sealed against moisture leakage. The joints are first laid up in mortar just as any other vertical joints would be. After the mortar has stiffened slightly, the joints are raked out to a depth which will allow placement of a backer rod or bond breaker tape, and a sealant joint of the proper depth. Concrete masonry moisture shrinkage always exceeds thermal and moisture expansion because of the initial moisture loss experienced after manufacture. So, even though control joints contain hardened mortar or hard rubber shear keys, they can accommodate reversible expansion and contraction which occurs after the initial curing shrinkage.

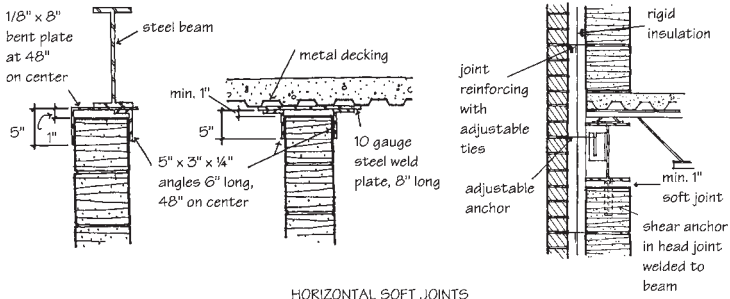
In masonry, an expansion joint is a continuous open joint or plane designed to accommodate the permanent moisture expansion of brick and other clay units. Brick moisture expansion always exceeds reversible thermal expansion and contraction, so the joint cannot contain mortar or other hard materials. *Figure 9-13* shows several methods of constructing vertical expansion joints and horizontal soft joints. Compressible fillers may be used to keep mortar out of the joints during construction, because even small mortar bridges can cause localized spalling of the unit faces where movement is restricted (see *Fig. 9-14*). Filler materials should be at least as compressible as the joint sealant which will be used, and the compressibility of the sealant must be considered in calculating joint width.

The required width for control joints and expansion joints can be determined by adding the widths required for thermal movement, moisture movement, and construction tolerances. If the calculated width based on an assumed joint spacing is too narrow for proper sealant function, or too wide for aesthetic reasons, the joint spacing can be increased or decreased and the width recalculated.

Required joint width must take into account the movement capability of the sealant itself in both extension and compression. An elastomeric sealant rated $\pm 25\%$ can tolerate a maximum movement of $+25\%$ of the joint width when extended, and -25% of the joint width when compressed. The joint must therefore be four times the expected movement ($100/25 = 4$). A more elastic sealant rated $\pm 50\%$ requires a joint width twice the expected movement ($100/50 = 2$). A sealant reported as $+100/-50\%$ is governed by its compressibility, so the joint still must be twice the calculated movement to allow room for the compressed thickness of the sealant itself. ASTM C1472 gives a basic formula for calculating joint width for thermal movement ($W_i = \Delta L_i/S$), but to allow for imprecisions in determining surface temperatures, imperfect workmanship, and other unknowns, some researchers recommend using sealants at only a percentage of their rated movement capacity. The amount of reduction should depend on the particular circumstances of a joint design and the desired factor of safety. With



VERTICAL CONTROL JOINTS



HORIZONTAL SOFT JOINTS

Figure 9-12 CMU control joints for shrinkage crack control and horizontal soft joints to accommodate beam or floor deflection above.

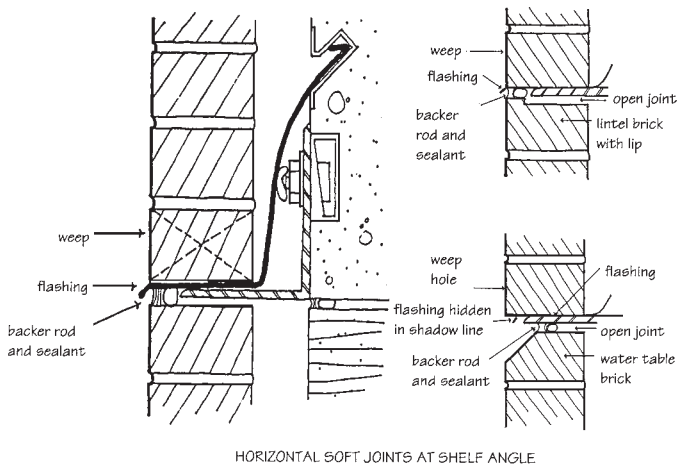
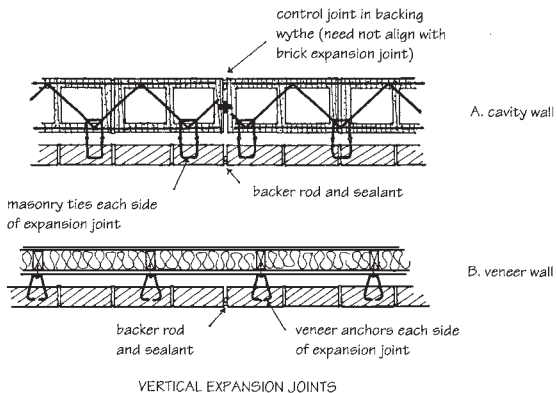


Figure 9-13 Clay masonry expansion joints.



Figure 9-14 Mortar bridges across an expansion joint can cause localized spalling where movement is restricted.

this additional limitation, using the sealant at only 80% of its capacity for this example, the formula is then

$$W_t = \frac{\Delta L_t}{0.8S} \quad (9.4)$$

where W_t = minimum joint width for thermal movement only, in.

S = sealant movement capacity

ΔL_t = dimensional change due to thermal movement, in. [using equation (9.3)]

To calculate the joint width required for moisture movement in masonry, the coefficients in *Fig. 9-4* must be used in the formula

$$W_m = \frac{M_c}{100(L)} \quad (9.5)$$

where W_m = minimum joint width for moisture movement only, in.

M_c = moisture movement coefficient (see *Fig. 9-4*)

L = panel length or joint spacing, in.

Material fabrication and erection tolerances must also be considered in determining the required joint width. When unanticipated construction tolerances result in increased or decreased joint width, sealant performance is seriously affected. Narrow joints especially are a frequent cause of sealant

joint failure. Although normal tolerances for different materials vary considerably (see Chapter 15), a reasonable estimate must be made of the combined or net effect on the joint. Once that allowance is determined, it must be added to the previously calculated joint width requirements in the formula

$$W = W_t + W_m + W_c \quad (9.6)$$

where W = total calculated joint width, in.

W_t = minimum joint width for thermal movement, in.

W_m = minimum joint width for moisture movement, in.

W_c = minimum joint width for construction tolerances, in.

The sealant joint width calculation process is summarized in *Fig. 9-15*. If the calculated joint is too wide for aesthetic considerations, the assumed spacing or panel length can be decreased and the width recalculated.

In order for the sealant to function properly, most sealant industry sources recommend that for butt joints up to $\frac{1}{2}$ in. wide, joint depth should be less than or equal to the width, with 2:1 a preferred ratio. Sealant depth should be constant along the length of the joint, and should never be less than $\frac{1}{4}$ in.

9.3.2 Joint Locations

The calculations for joint width and spacing apply to continuous walls with constant height and thickness. Joint locations may be adjusted, or additional joints may be required for other conditions. The exact location of control and expansion joints will be affected by design features such as openings. Rule-of-thumb movement joint locations for brick and block construction include

- Changes in wall height (see *Fig. 9-16*)
- Changes in wall thickness (such as pilasters)
- Offsets in parallel walls (see *Fig. 9-17*)
- One side of openings 6 ft or less in width (see *Fig. 9-18*)
- Both sides of openings more than 6 ft wide
- Near corners in clay masonry construction (see *Fig. 9-19*)

Movement joints should always be located at points of weakness or high stress concentration such as these, and coincidentally with movement joints in floors, roofs, foundations, or backing walls. Joints should be located at the calculated spacing along walls or sections of walls which are not interrupted by such elements.

In brick walls, expansion joints should be located near the external corners of buildings, particularly when the masonry is resting on a concrete foundation. The shrinkage of the concrete, combined with the expansion of the brick, can cause the wall to slip beyond the edge of the foundation or to crack the concrete (see *Fig. 9-20*). The opposing push of the intersecting veneer wythes can also crack the brick itself (see *Fig. 9-21*).

Brick parapet walls experience differential movement from the walls below caused by a variation in exposures. Even in a light rain, the tops and corners of a building will always get wet, but the rest of the walls may stay dry, resulting in more wet-dry cycles at the parapet. The temperature of the building enclosure walls is also moderated by interior heat and air conditioning, so the parapet is exposed to higher and lower extremes. As a result of these

JOINT WIDTH	THERMAL MOVEMENT	MOISTURE MOVEMENT
$W = W_t + W_w + W_c$ where: W = design joint width W_t = thermal movement W_w = moisture movement W_c = construction tolerance (varies with type of material)	$W_t = (T_c)(\Delta T)(L)$ where: T_c = thermal expansion coefficient (from Table 1) $\Delta T = T_s - T_w$ T_s = summer air temp. (°F) plus heat capacity constant (H from Table 2) x solar absorption coefficient (A from Table 3) T_w = winter air temperature (°F)	$W_w = (M_c/100)(L)$ where: M_c = moisture movement coefficient (Table 4) L = panel length or joint spacing, inches

TABLE 1 Thermal Movement Coefficient (T_c)

Material	T_c
Brick	
clay or shale	3.6
fire clay	2.5
Concrete Masonry	
normal weight	
sand and gravel aggregate	5.2
crushed stone aggregate	5.2
medium weight	
air-cooled slag	4.6
lightweight	
coal cinders	3.1
expanded slag	4.6
expanded shale	4.3
pumice	4.1
Stone	
granite	2.8–6.1
limestone	2.2–6.7
marble	3.7–12.3
sandstone	4.4–6.7
slate	4.4–5.6
travertine	3.3–5.6
Concrete	
calcareous aggregate	5.0
siliceous aggregate	6.0
quartzite aggregate	7.0

TABLE 2 Constant for Heat Capacity (H)

Type of Material	(H)
Low heat capacity materials [§]	100 or 130
Solar radiation reflected on low heat capacity materials [§]	
High heat capacity materials [§]	75 or 100
Solar radiation reflected on high heat capacity materials [§]	

[§] Materials such as EIFS and well-insulated metal panel curtain walls have low thermal storage capacity. Materials such as concrete and masonry have high thermal storage capacity.

[¶] If the wall surface receives reflected as well as direct solar radiation, use the larger coefficient. Reflected radiation may be from adjacent wall surfaces, roofs, and paving.

TABLE 3 Solar Absorption Coefficient (A)

Material	A
Brick, light buff	0.50-0.70
Brick, red	0.65-0.85
Brick, white	0.25-0.50
Concrete, natural	0.65
Martile, white	0.58
Surface color	
black	0.95
dark gray	0.80
light gray	0.65
white	0.45

TABLE 4 Moisture Movement Coefficient (M_c)

Material	M_c	Type of Movement
Concrete, gravel aggregate	-0.03 to -0.08	shrinkage
Concrete, limestone aggregate	-0.03 to -0.04	shrinkage
Concrete, lightweight aggregate	-0.03 to -0.09	shrinkage
Concrete block, dense aggregate	-0.02 to -0.06	shrinkage
Concrete block, lightweight aggregate	-0.02 to -0.06	shrinkage
Brick, clay face	+0.03 to +0.08	expansion

Figure 9-15 Summary of method for calculating required sealant joint width. (Based on ASTM C1472, Standard Guide for Calculating Movement and Other Effects When Establishing Sealant Joint Width. Copyright ASTM, 100 Barr Harbor Drive, West Conshohocken, PA 19428.)



Figure 9-16 Expansion joint at change in brick wall height.

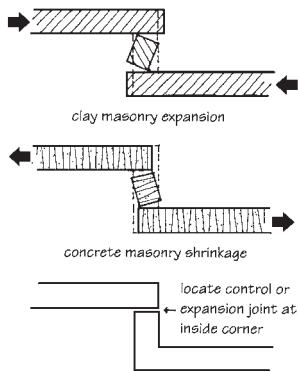


Figure 9-17 Movement at offsets in parallel walls requires placement of control or expansion joints to prevent cracking.

differences, cracking, slippage, and separation often occur at or near the roof line. Extra expansion joints can be located in the parapet to accommodate movement. Masonry walls and parapets can also be reinforced with bond beams to increase resistance to shrinkage and expansion (see Fig. 9-22 and Chapter 10).

The joint reinforcement used to control shrinkage in concrete masonry walls affects the required location of control joints. The National Concrete Masonry Association (NCMA) provides tables to determine control joint spacing

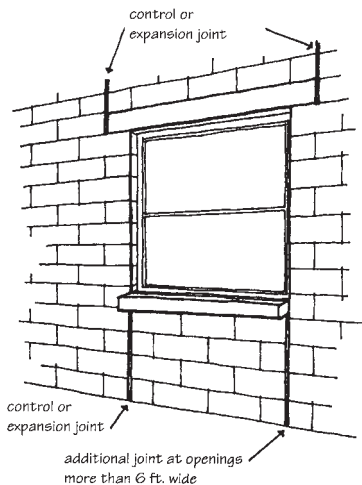


Figure 9-18 Movement joints at openings.

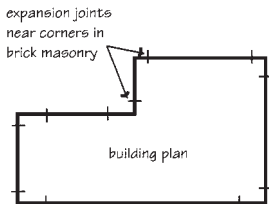


Figure 9-19 Locate expansion joints near corners in brick masonry.

based on joint reinforcement size and spacing (see Fig. 9-23). Joint reinforcement should not continue across control joints (see Fig. 9-24). The details in Fig. 9-25 show how to combine brick and CMU in the same wall with minimal risk of cracking.

9.3.3 Accommodating Movement Joints in Design

Requirements for the location of movement joints in masonry are dictated by the expansion and contraction characteristics of the materials, but designers can also exercise some control over joint location and the aesthetic impact of



Figure 9-20 Brick expansion forces may exceed tensile strength of concrete. (Photo courtesy BIA.)

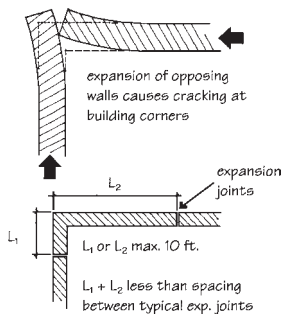


Figure 9-21 Locate expansion joints near corners in brick masonry construction to prevent cracking caused by expansion of opposing walls. (From BIA Technical Note 18A.)

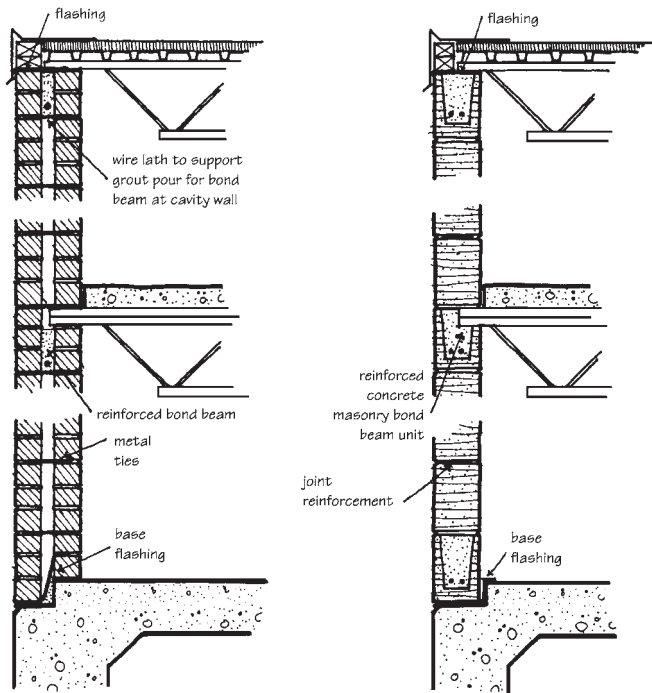


Figure 9-22 Reinforced bond beams help limit brick expansion and CMU shrinkage cracking.

the joints themselves. The objective of movement joint placement is dividing a wall into smaller panels of masonry that can expand and contract independently of one another. The smaller the panels, the lower the cumulative stress will be and the less likely it is that cracking will occur. Wall panels that are more square than rectangular also have less stress buildup. Movement joints will be less noticeable in the appearance of a building if the exterior elevations are designed with joint locations in mind instead of placing them as an afterthought in a completed design. Just as the joint pattern in a stucco facade is part of the overall design, so too should masonry joints be a design element in masonry buildings. Joints can even be articulated with special shape units to make their visual impact stronger. Alternatively, the joints can be hidden in the shadow of a protruding pilaster, while the series of pilasters articulates the panelized sections of the wall.

Maximum Spacing of Horizontal Reinforcement to Meet Criteria of 0.025 in ² per Foot of Wall Height	
Reinforcement Size	Maximum Vertical Spacing (in.)
W1.7 (9 gauge) two wire [§]	16
W2.8 (3/16 in.) two wire [§]	24
W1.7 (9 gauge) four wire [†]	32
W2.8 (3/16 in.) four wire [†]	48
No. 3 bars	48
No. 4 bars	96
No. 5 bars or larger	144

[§] Two-wire joint reinforcement = one wire per face shell.

[†] Four-wire joint reinforcement = two wires per face shell.

Recommended Control Joint Spacing For Above Grade Exposed Concrete Masonry Walls [§]	
Length to Height Ratio	Spacing Between Joints (ft.)
1-1/2	25

[§] Table based on horizontal reinforcement with equivalent area of at least 0.025 in² per foot of wall height to keep random cracks closed. See table above.

[†] Spacing based on experience over wide geographical area. Adjust spacing where local experience justifies, but not to exceed 25 ft. on center.

• Applies to all concrete masonry units.

Figure 9-23 Control joint spacing for concrete masonry construction. (From *National Concrete Masonry Association, TEK Bulletin 10-2B, NCMA, Herndon, VA.*)

The location of window and door openings often governs movement joint placement because of the frequency of their occurrence. In general, joints should be located at one side of openings less than 6 ft wide and at both sides of openings wider than 6 ft. When the masonry above an opening is supported by a precast concrete, cast stone, or reinforced CMU lintel, the adjacent movement joint must be located at the ends of the lintel as shown in *Fig. 9-18*. This creates an odd-looking pattern that is not very attractive. As an alternative, movement joints can be located at the midpoint between windows. If the spacing is relatively wide (or simply as an added measure of safety), joint reinforcement can be added in the courses immediately above and below the openings to strengthen the panel (see *Fig. 9-26*). When the masonry is supported on a loose steel lintel that simply spans between the masonry on each side, special detailing can be used to avoid offsetting the joint to the end of the lintel. A piece of flashing placed under the lintel bearing area creates a slip plane so that the end of the lintel can move with the masonry over the window. With this detailing, the movement joint can then be placed adjacent to the window and



continuous joint reinforcement
interferes with proper functioning
of control joints

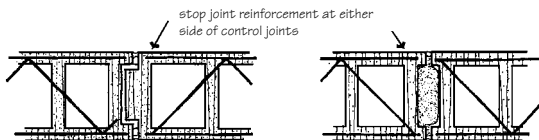
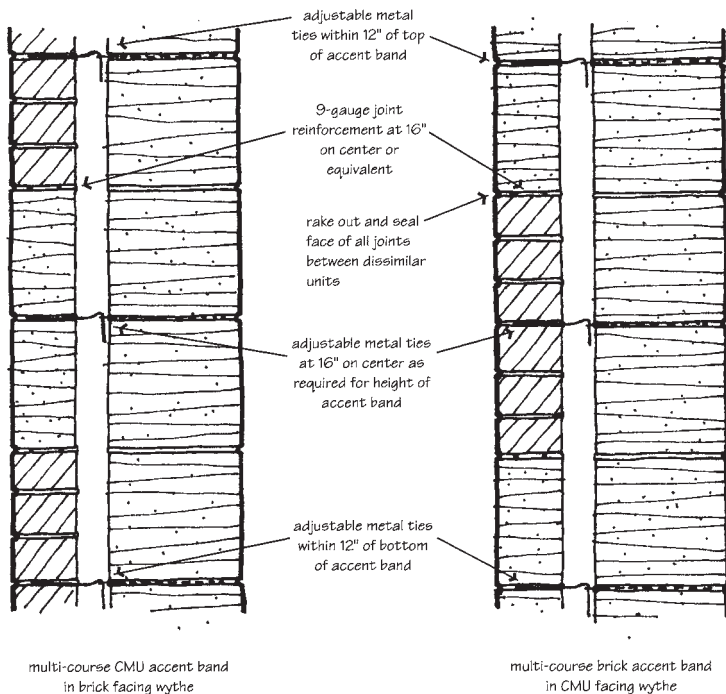


Figure 9-24 Joint reinforcement should *not* be continuous across control joints.

run in a continuous vertical line (see *Fig. 9-27*). When the masonry above an opening is supported on shelf angles that are attached to the structure, a control or expansion joint can be located immediately adjacent to the opening and continue straight up the wall past the horizontal support.

Joint reinforcement can also be used to group closely spaced windows into larger panels so that the movement joints can be spread farther apart. The joints on either side of such a grouping must be sized large enough to accommodate the movement of the larger panel. In the elevation shown in *Fig. 9-28*, the two bed joints immediately above and below the groups of windows are reinforced with two-wire, truss-type joint reinforcement. Oversized movement joints can then be placed at either end of the window groupings. Because the joints are large, an offset or pilaster can be created in the wall at the joint locations to make them less noticeable. Calculating the expected movement in the masonry panels in a situation like this is very important, to be sure the joints are wide enough. An extra $\frac{1}{8}$ in. should also be added to the planned joint width to allow for construction tolerances.

Choosing the right color of sealant can also affect the appearance of movement joints. Sealant color may be selected similar to either the units or the mortar color, but should be slightly darker than the unit or mortar whenever possible. Different sealant colors can blend with different bands of unit colors alternating through the height of the facade. Sand can also be rubbed



DETAILS FOR COMBINING BRICK AND CMU IN THE SAME WYTHE

Figure 9-25 Differential movement between brick and CMU must be accommodated when combining units in the same wythe to create accent bands. (Based on recommendations in *National Concrete Masonry Association*, TEK Bulletin 5-2A, NCMA, Herndon, VA.)

into the surface of fresh sealant to remove the sheen and give it a weathered look. Project specifications should include general guidelines on the location of movement joints, but the architectural drawings should always show the location of control and expansion joints on the building elevations.

9.4 MOISTURE PROTECTION Moisture is a consistent threat to any building. As wind-driven rain, ice, sleet, snow, hail, or water vapor, it may penetrate building walls, causing corrosion, decomposition, efflorescence, or mold.

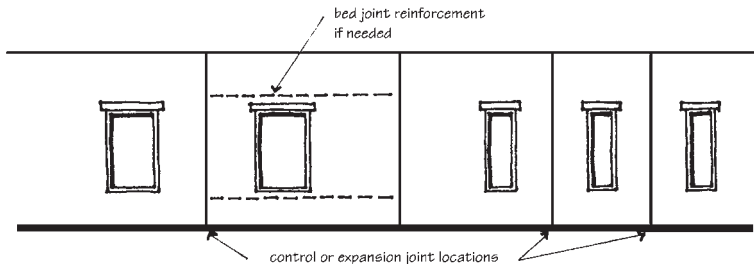


Figure 9-26 With proper planning, expansion and control joints can be placed between rather than immediately adjacent to window and door openings.

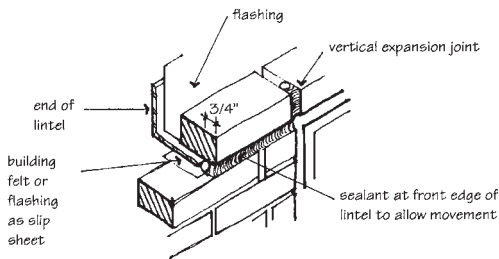


Figure 9-27 Expansion joint at steel lintel.

Masonry materials are porous, and absorptive. Rain can penetrate masonry walls through cracks or separations at the mortar bond line and through defects at copings, sealant joints, windows, parapets, and so on. Masonry does not support mold growth, but the sheathing and framing behind veneers can be a food source for mold spores. For successful performance, it is important to limit rain penetration and expedite moisture removal. The primary means of limiting moisture penetration are complete and intimate bond between units and mortar, full head and bed joints, adequate allowance for movement to prevent cracking, and good details. The primary means of removing moisture from the wall are continuous flashing, unobstructed weep holes, and good details.

Single-wythe walls are most vulnerable to moisture penetration and require the greatest care in material selection, design, and workmanship. Cavity walls and veneers which have a complete separation between backing and facing provide the best protection. This *drainage wall* concept permits moisture which enters the wall or condenses within the cavity to be collected on flashing membranes and expelled through weep holes (see Fig. 9-29). At

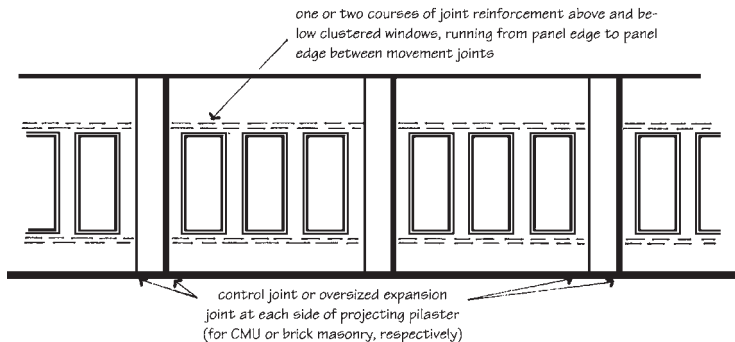


Figure 9-28 Grouping windows between movement joints.

the base of the wall, and at any point where the cavity is interrupted, such as shelf angles, floors, or openings, a layer of flashing must be installed, and with it, a row of weep holes. The cavity in a drainage wall should be at least 2 in. wide (exclusive of insulation or sheathing), because narrower cavities are difficult to keep clean of mortar droppings during construction. Building codes require a minimum of only 1 in., and corrugated metal anchors cannot span more than a 1 in. cavity.

A variation on the drainage wall concept called the *rain screen wall* is based on rapidly equalizing the air pressure between the cavity and the outside atmosphere. Blowing winds during a rain cause a low-pressure condition in the cavity. In seeking a natural state of equilibrium, air moves from the high-pressure zone outside to the low-pressure zone in the cavity. With air infiltration, rainwater is carried through the wall face via any minute cracks which may exist at the mortar-to-unit interface. Under such a pressure differential, rainwater which would normally run down the face of the wall is literally driven or sucked into the wall. Venting and compartmentalizing the cavity equalizes the pressure differential to eliminate the force which pushes or pulls moisture through the wall, and also promotes faster drying.

The rain screen principle was developed in the metal curtain wall industry, and requires some special detailing for adaptation to masonry construction. To function properly as a pressure-equalized rain screen, the wall section must include an air barrier, and the cavity must be divided into smaller compartments. The cavity must be blocked both horizontally and vertically, to prevent wind tunnel and stack effects. Without an air barrier and compartmenting, the horizontal flow of air around building corners and through the backing wall prevents pressure equalization in the wall cavity. Shelf angles in conventional masonry cavity wall and veneer construction provide compartmental barriers to the vertical flow of air, but corners require special detailing. Each "compartment" must be properly vented so that the pressure change occurs as rapidly as possible. Rain screen vents should be located near the top of the wall or panel section, and constructed in the same manner as open head joint weep holes. Theoretically, if the area of the vents

- **Barrier wall systems** must entirely exclude rain penetration at the exterior wall surface because there is no accommodation for moisture drainage. Barrier walls assume that surfaces are impervious and rely on the integrity of joint sealants and perimeter detailing to achieve adequate performance. Some systems require unrealistic perfection in the construction process to prevent moisture damage to component materials. Precast concrete cladding, concrete tilt wall construction, and many EIF systems typically use barrier wall strategies.
- **Drainage wall systems** are more forgiving because they do not require the total exclusion of moisture. A drainage wall can tolerate minor rain penetration because its drainage capability prevents moisture accumulation and damage to materials. A continuous clear and open cavity or drainage plane is required behind the exterior surface. Flashing membranes and weep holes must be properly detailed and installed to control moisture flow and facilitate drying. Masonry cavity and veneer walls, some precast concrete cladding, some newer EIF systems, and most stucco applications are typically designed as drainage walls.
- **Rain screen wall systems** incorporate the elements of a drainage wall plus air pressure equalization for additional protection against wind-driven rain. Rain screen systems require compartmentalization of the drainage cavity or air chamber behind the exterior surface and the incorporation of an air barrier in the backing wall. The rain screen concept works most effectively in glass and metal curtain wall systems where the air chamber size is very small and air pressure equalization is very rapid. Although rain screen technology can be used with concrete and masonry walls, it is not common in the United States and the enhanced performance increases construction costs.

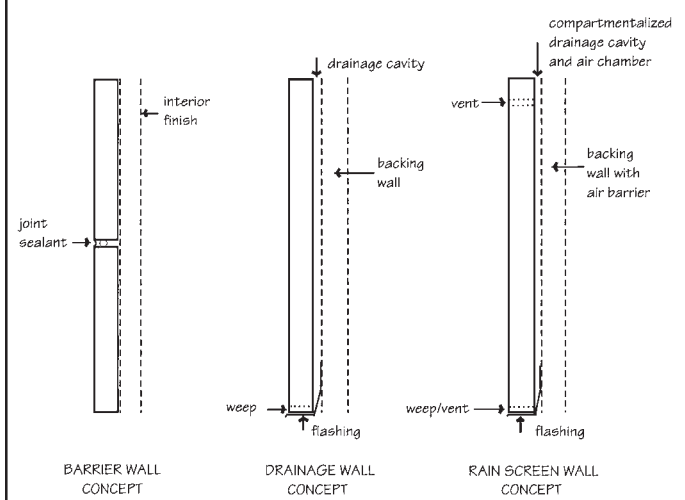


Figure 9-29 Exterior wall systems may incorporate a number of moisture protection strategies, but can generally be divided into three basic wall types: barrier walls, drainage walls, and rain screen walls. (From Beall and Jaffe, *Concrete and Masonry Databook*, McGraw-Hill, New York, 2003.)

in the outer wythe is at least three times greater than the area of unintentional openings in the backing wall, then the air pressure in the cavity will be about the same as the outside air pressure. In practice, however, the ratio is often increased to 10:1 to provide a factor of safety that ensures equalization. Aesthetically, rain screen vents look best if they are located at the same spacing as the weep holes in the lower course of the wall.

9.4.1 Prevent Moisture Accumulation

An important consideration in the design of masonry walls is the proper location of flashing and weep holes. Although moisture penetration can be limited through good design and workmanship, it is virtually impossible to entirely prevent moisture from entering a masonry wall. Without proper flashing, water that does penetrate the wall cannot be diverted back to the exterior. Continuous flashing should be installed at the bottom of the wall cavity and wherever the cavity is interrupted by elements such as shelf angles and lintels. Flashing should be placed over all wall openings, and at all window sills, spandrels, caps, copings, and parapet walls (see Fig. 9-30). Single-wythe walls can drain moisture through ungrouted cores and also require flashing at the same coping, parapet, head, sill, and base locations (see Fig. 9-31). Flashing in single-wythe walls can be installed using conventional brick or CMU, or using a special proprietary flashing block design licensed to various block manufacturers (see Fig. 9-32). All masonry walls should all be set on a recessed ledge at the slab edge so that flashing and weeps are below the finish floor elevation, and a minimum of 6 in. above finish grade.

The top of the vertical leg of the flashing should be installed so that water cannot flow behind it (see Fig. 9-33). The flashing should also extend beyond the face of the masonry so that moisture collected on the surface cannot flow around the edge and back into the wall below. Metal flashing can be turned down and hemmed to form a drip, but plastic or rubber flashing must be extended during placement and then cut off flush with the wall after the units are laid. Bituminous flashing or metal flashing with bituminous coatings requires installation with a separate metal drip (see Fig. 9-34) to avoid exposure to the sun, which can cause bleeding, emulsification, and staining. Special flashing details at shelf angles are shown in Chapter 10. Flashing should be continuous around corners (see Fig. 9-35), and at horizontal terminations the flashing should be turned up to form an end dam (see Fig. 9-36). Where masonry abuts door jambs, curtain walls, storefront systems, or other cladding materials, stop flashing in the first head joint adjacent to the interface and form an end dam. Where structural framing interrupts the backing wall, flashing should be continued across the face of the framing, and the gaps between the backing wall and columns or spandrel beams should be sealed against air and moisture penetration (see Fig. 9-37).

Flashing at window penetrations is also critical in preventing water penetration. Where backing walls are of stud frame and sheathing, the substrate must be wrapped and protected from moisture damage (see Figs. 9-38 and 9-39). Windows and doors that are recessed even slightly from the face of the wall will be better protected against leaks than those installed flush with the masonry, particularly when construction tolerances cause the window locations to fall outside the plane of the wall (see Fig. 9-40). Sheathing that is not inherently moisture resistant must also be protected with a layer of building paper, felt, or building wrap. Only a few sheathing materials are

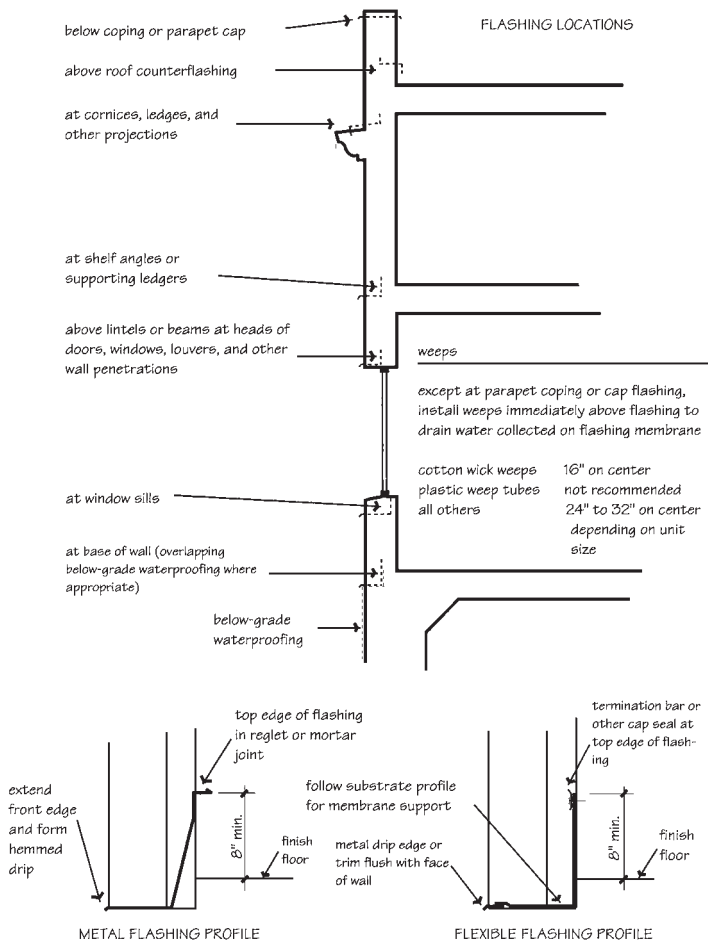
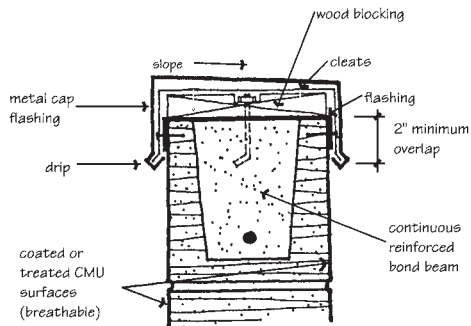
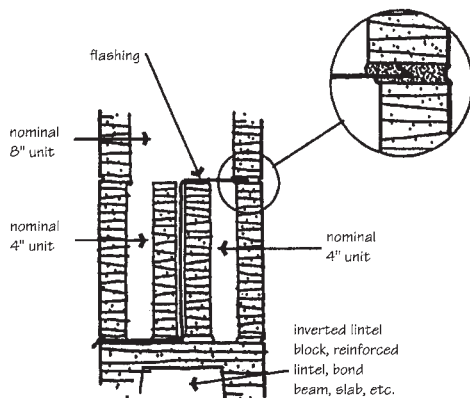


Figure 9-30 Masonry flashing and weep placement. (From *Beall and Jaffe, Concrete and Masonry Databook, McGraw-Hill, New York, 2003.*)



METAL CAP FLASHING FOR SINGLE-WYTHE CMU WALL



STEP FLASHING AT SINGLE-WYTHE CMU WALL

Figure 9-31 Flashing at single-wythe walls.

resistant to both moisture and mold growth. CMU backing walls are typically coated with a dampproof mastic to shed moisture and reduce air penetration.

Flashing at chimneys and roof-wall intersections is also very important. Metal counterflashing inserted into a masonry joint laps down over the roof system base flashing to keep water from getting behind it (see Fig. 9-41). To drain moisture from the wall cavity above the roof level requires through-wall flashing. Flashing installed in a saw-cut reglet will not stop the flow of

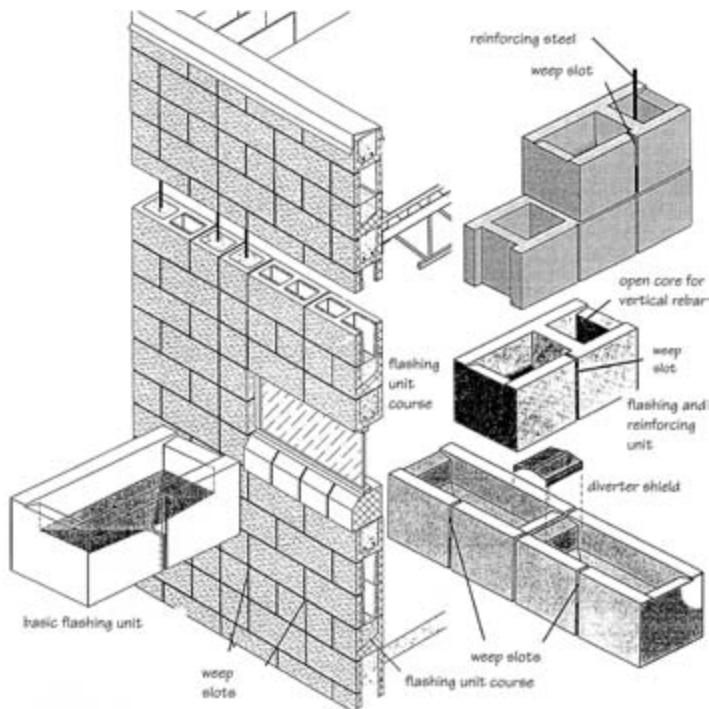


Figure 9-32 Patented block design with self-flashing and weeping capability for single-wythe concrete masonry walls.

moisture down the cavity. Where the flashing must be installed at an angle to follow the roof slope, it is “stepped” from one course to the next. Each course must be overlapped or sealed to prevent water from running underneath the flashing and back into the wall (see Fig. 9-42). Step flashing can also be used across the top of round or arched openings, with the same stipulation for sealing against water reentering the wall. Through-wall flashing, counterflashing, and flashing reglets at roof-wall intersections should be designed and fabricated as two-piece or three-piece assemblies to accommodate construction tolerances and dimensional variations. Reglets provide an effective means of removing and replacing roof flashings without disturbing the adjacent masonry (see Fig. 9-43). Surface-mounted reglets are intended for use on concrete walls and should not be used on masonry.

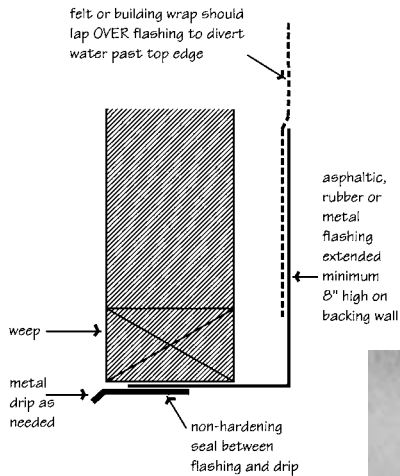


Figure 9-33 Lap moisture-resistant membrane over flashing.

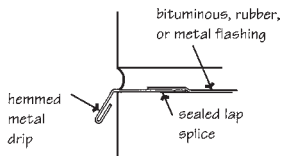
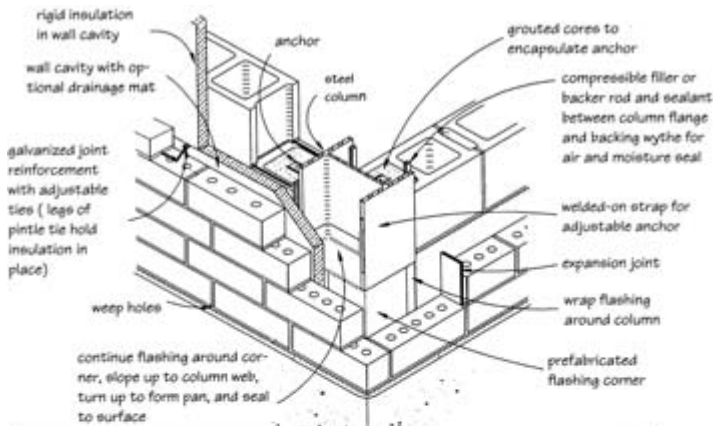
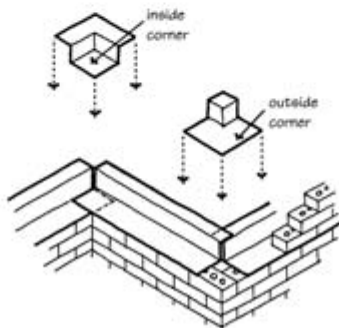


Figure 9-34 Metal drip edge.



COMPLEX FLASHING DETAIL AT CORNER COLUMN WEB

(Adapted from Laska, *Masonry and Steel Detailing Handbook*, 1993)



PREFABRICATED CORNER FLASHING

Figure 9-35 Flashing must be continuous at building corners to prevent water penetration.

Flashing is generally formed from sheet metal, rubber, bituminous membranes, or composite materials selected on the basis of cost and suitability. Joints in the flashing should be lapped and sealed. A double bead of non-hardening butyl caulk or urethane sealant will provide better accommodation of thermal expansion and contraction in metal flashings than soldered

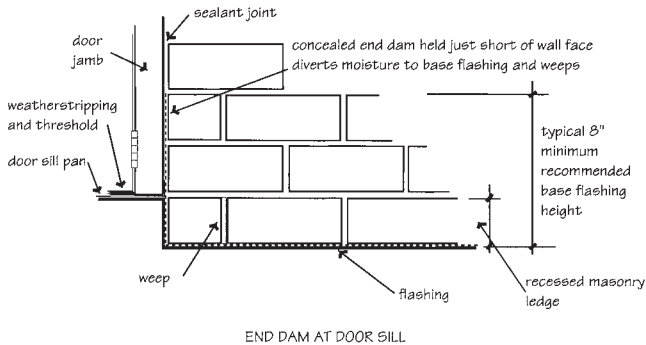
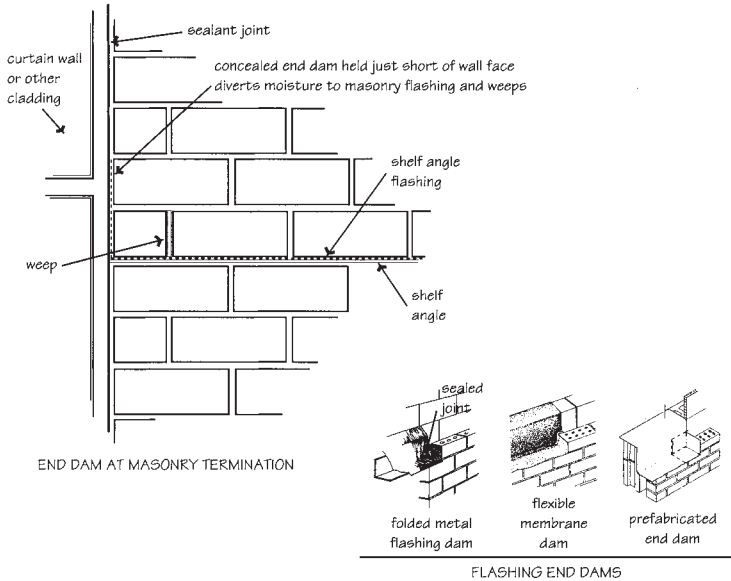


Figure 9-36 Form end dams wherever flashing terminates at windows, doors, and against adjacent construction.

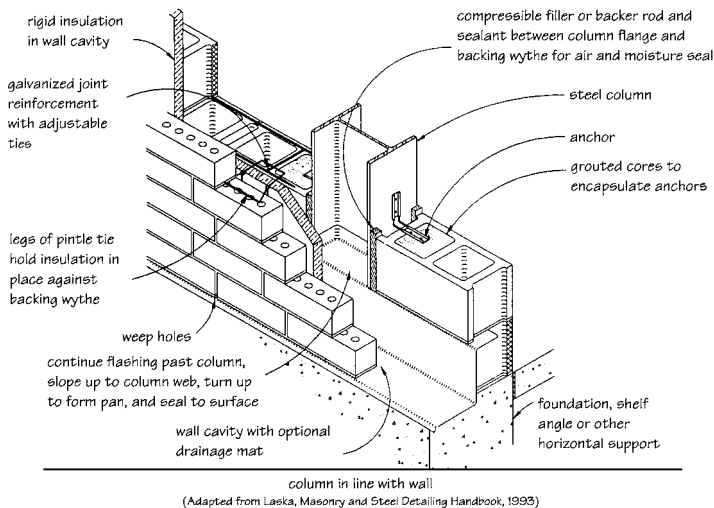


Figure 9-37 Seal gaps in backing wall against air and water penetration. (Adapted from Laska, *Masonry and Steel Detailing Handbook*, Aberdeen Group, 1993.)

joints. (Chapter 7 discusses various materials and their performance.) Both installation and material costs vary, and no general recommendation can be made solely on an economic basis. It is critical, however, that only high-quality materials be used, since failure can lead to significant damage, and replacement is both difficult and expensive. Weep holes are located in the head joints immediately above the flashing. Spacing of weep holes should generally be 24 or 32 in. on center for open joints depending on unit size, and 16 in. on center for those using wick material. Weep hole tubes should not be used, because the small openings are too easily obstructed by mortar droppings, insects, or other debris.

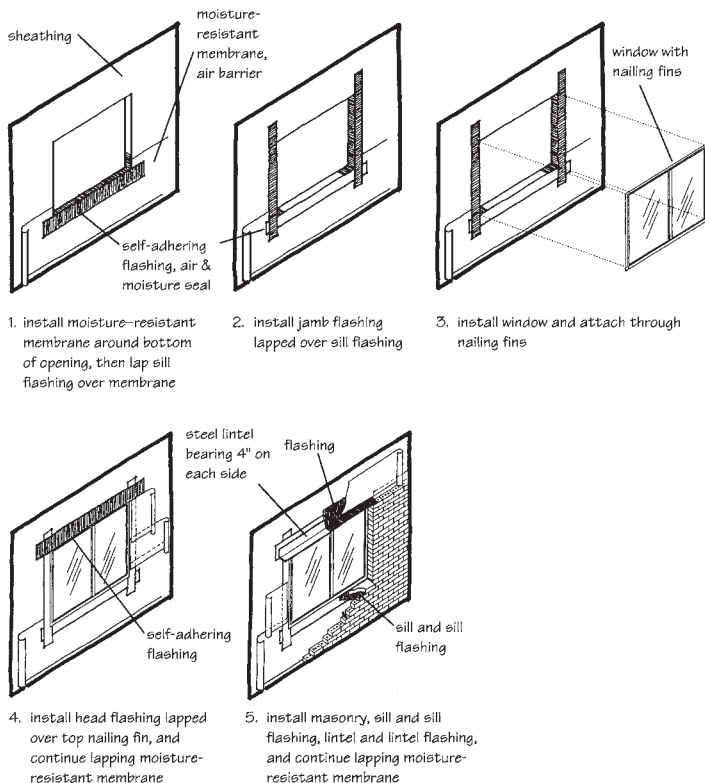
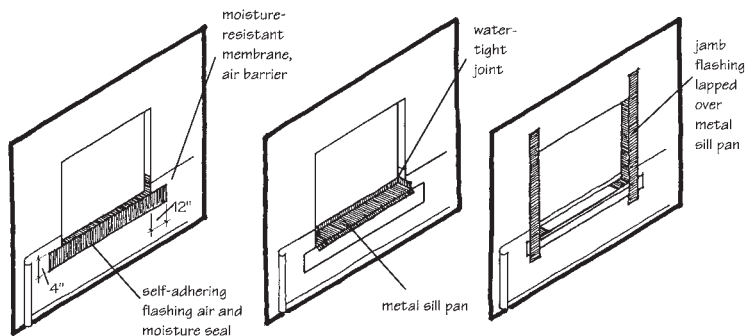


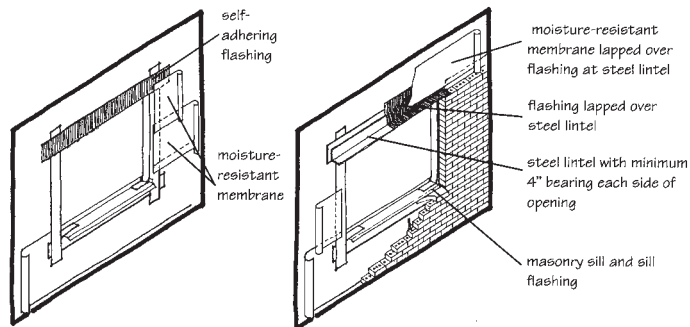
Figure 9-38 Residential window flashing.

9.4.2 Limit Moisture Penetration

Full mortar joints are essential in limiting water penetration through masonry walls. Mortars should be selected on the basis of performance. Cracking or separating of bond between mortar and masonry unit invites the intrusion of water, and good bond must be maintained at all contact surfaces. Type N mortar is recommended for above-grade work with normal exposure. Types M and S should be used only for special conditions (see



1. Install moisture-resistant membrane around bottom of opening, then lap sill flashing over membrane.
2. Install metal sill pan with back and end dams.
3. Install jamb flashing lapped over metal sill pan, sill flashing, and moisture-resistant membrane, air barrier.



4. Install flashing to protect substrate at window head, and continue lapping moisture-resistant membrane.
5. Install masonry, sill, and sill flashing, lintel and lintel flashing, and continue lapping moisture-resistant membrane.

Figure 9-39 Commercial window flashing.



Figure 9-40 Protruding window invites leaks at head.

Chapter 6 for mortar type recommendations). All head and bed joints must be fully mortared and tooled for effective weather resistance. The concave and V joints shown in *Fig. 9-44* are most effective in excluding moisture at the surface. Steel jointing tools compress the mortar against the unit, forming a tight bond at the unit-mortar interface, but mortar joints that are improperly tooled will allow water to penetrate freely (see *Figs. 9-45 and 9-46*). Mortar must be mixed with the maximum amount of water to assure good bond. The mortar mix must contain enough water to provide good workability and to assure complete hydration of the cement even after the water content has been reduced by unit suction. Optimum water content is also affected by weather conditions, so the mason should be allowed to judge the necessary amount based on workability. In hot, dry, or windy conditions, moist curing of the masonry after construction (for both clay and concrete units) can enhance bond and weather resistance by assuring proper hydration (see Chapter 15).

Masonry walls should be protected at the top by a roof overhang or roof-edge flashing. When parapets are necessary to the design, they should be carefully detailed to allow expansion, contraction, and differential movement, and to prevent water from penetrating the wall (see Chapter 10). Parapets have more extreme weather exposure than the rest of the wall, because the tops and edges of buildings get wet every time it rains while walls may stay dry depending on wind direction and duration of rain event (see *Fig. 9-47*). Since much of the water that penetrates masonry walls enters at the top, a roof overhang or protective fascia detail can eliminate many moisture problems, but parapets can be designed with effective weather protection. The details in *Figs. 9-48 and 9-49* illustrate both metal cap flashings and precast concrete or cast stone copings. Brick, concrete masonry, and precast concrete have different expansion and contraction characteristics, which can cause cracking and separation of mortar joints in a masonry coping (see *Fig. 9-50*). The mortar joints between precast or cast stone coping units should be raked out and filled with a sealant and bond breaker to assure adequate resistance to the penetration of rain or melting snow.

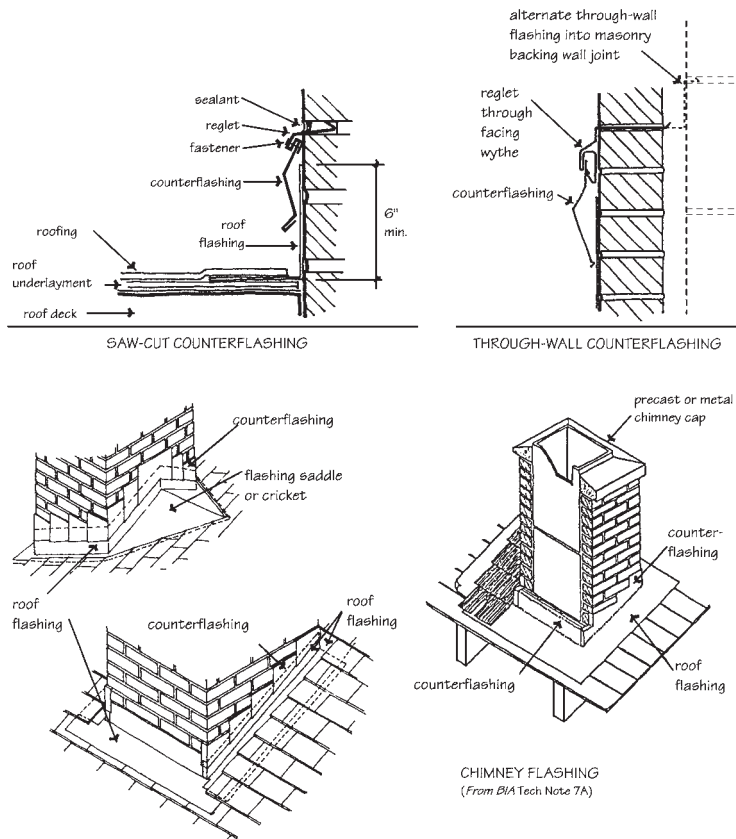


Figure 9-41 Flashing and counterflashing at roof-wall intersections and chimneys.

It is also difficult to anchor coping units mechanically without compromising the integrity of the flashing membrane. In high-wind areas, coping units should be as large and heavy as practical to resist wind uplift. For additional wind resistance, adjacent units can also be linked together by inserting stainless steel pins into holes drilled into the head joints. Brick

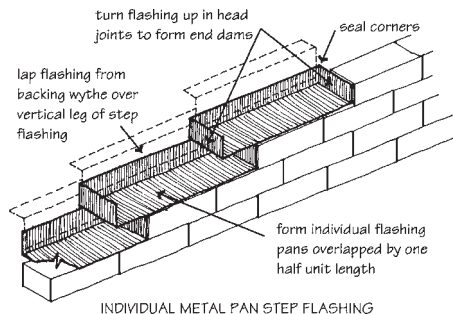
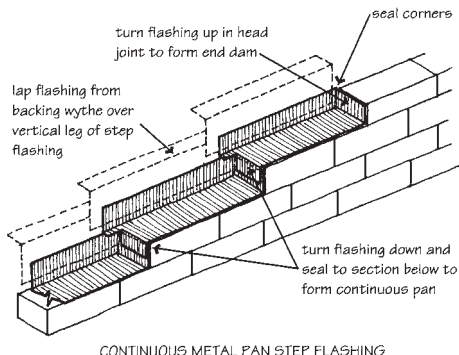


Figure 9-42 Two different methods of forming step flashing.

rowlocks should never be used as a coping, because the probability of cracking is very high (see Fig. 9-51).

Caulking between masonry and adjacent materials completes the masonry wall system. Door and window openings, intersections with dissimilar materials, penetrations, control joints, and expansion joints must all be fully and properly caulked to maintain the integrity of the system. Sealant materials must be selected for compatibility with the masonry, including adhesion, compression, extensibility, and staining characteristics. Workmanship must be of high quality, and should follow the recommendations of the Sealant, Waterproofing and Restoration Institute (SWRI). Joint surfaces should be properly cleaned and primed, backing material installed, and the sealant

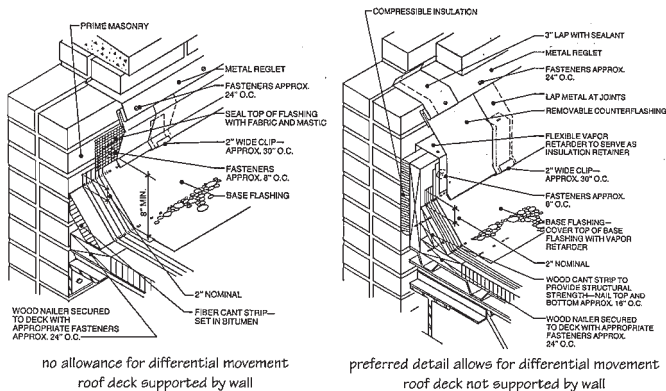
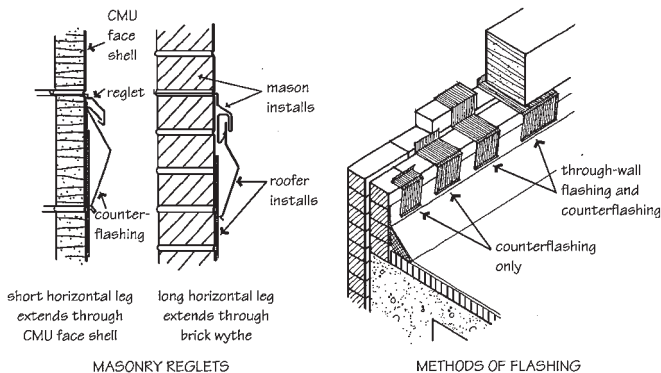


Figure 9-43 Reglets and counterflashing at roof-wall intersection.

applied in the proper joint geometry. Fillers placed in expansion joints to keep mortar out during construction may not be located at the correct depth for sealant application, or their depth may not be consistent, so they should not be used to form the back of the sealant joint. Fillers which interfere with correct installation of sealant and backer rods should be removed, and wet tooling of sealant joints should not be permitted. Masons must also assure

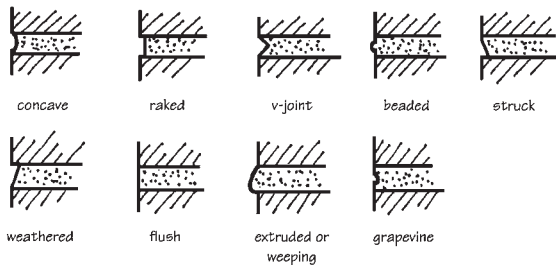


Figure 9-44 Mortar joint profiles can affect water penetration into the wall.

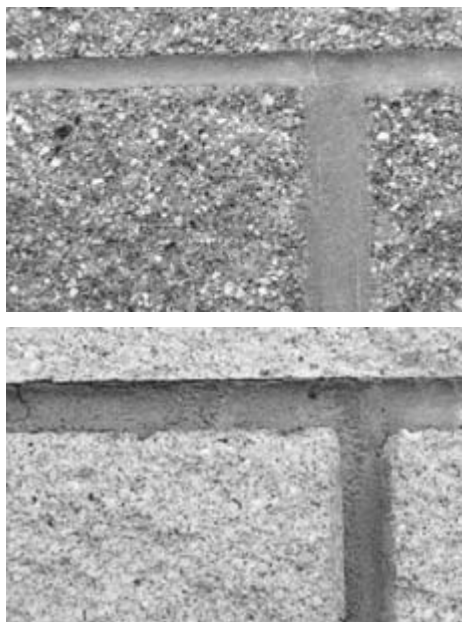


Figure 9-45 Good workmanship produces a joint with tight, compacted surface and good bond line adhesion. Poor workmanship produces rough joints with voids at the unit-mortar interface.

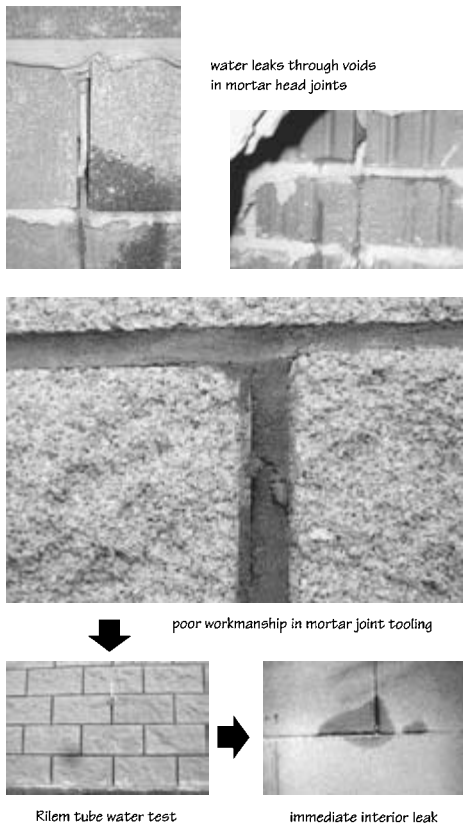
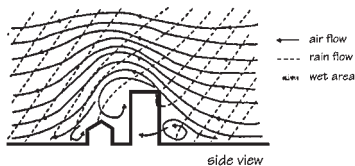


Figure 9-46 Poor workmanship in mortar joints increases water penetration through masonry walls.

that cavities of double-wythe walls and veneer walls are kept clean and the weep holes free of mortar droppings and bridges.

9.4.3 Material Selection

Proper selection of masonry units and mortar for expected weathering conditions is also an important factor. Clay brick for exterior use should conform



PATTERNS OF WIND-DRIVEN RAIN AGAINST BUILDINGS

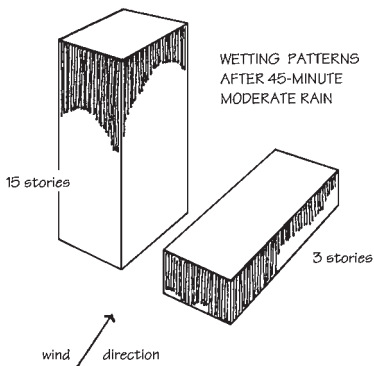
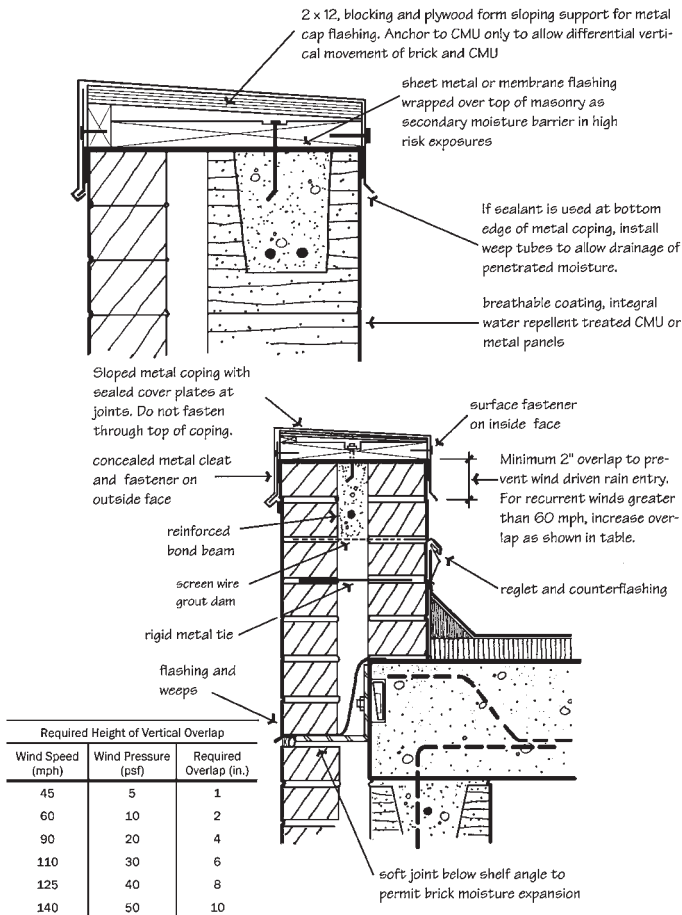


Figure 9-47 Wind and wetting patterns at the tops of buildings subject parapets and parapet copings to extreme weather exposure.

to ASTM C216, Grade MW or SW, depending on the severity of expected conditions (see Chapter 3). High-suction brick usually produces walls with poor bond. High-suction brick and porous concrete block can absorb excessive water from the mortar, thus preventing complete cement hydration at the unit surface. Mortar generally bonds best to clay masonry units with moderate initial rates of absorption (IRAs) between 5 and 25 g/min/30 sq in. Brick with initial rates of absorption higher than 25 or 30 g/min should be thoroughly wetted and then allowed to surface-dry before laying. This produces better bond and more weather-resistant joints. To test units in the field for high IRA, draw a circle on the bed surface of the brick with a wax pencil, using a 25-cent coin as a guide. With a medicine dropper, place 20 drops of water inside the circle and note the time required for it to be absorbed. If the time exceeds 1½ minutes, initial absorption is low to moderate and the unit need not be wetted. If the time is less than 1½ minutes, initial absorption is high and the brick should be thoroughly wetted and allowed to surface-dry before



(From AAMA Aluminum Curtain Wall Design Guide Manual)

Figure 9-48 Metal parapet caps.

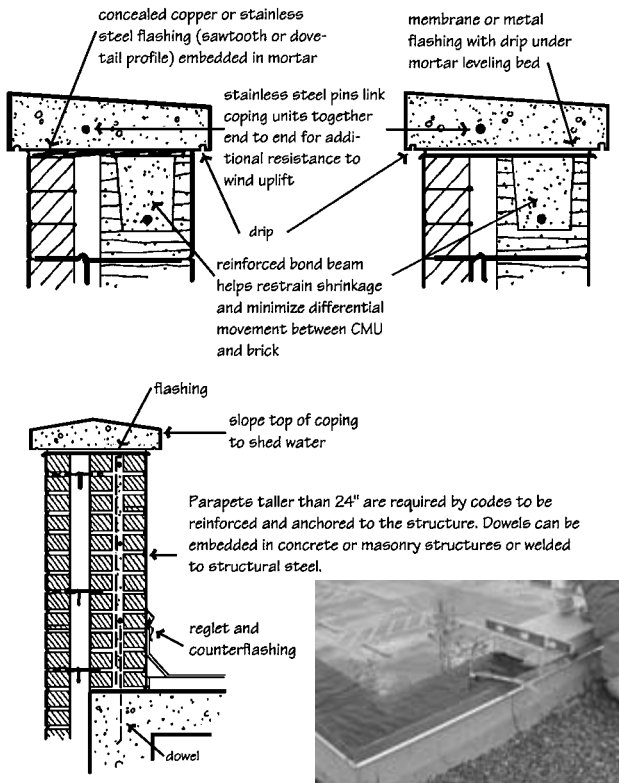


Figure 9-49 Precast concrete and cast stone parapet copings.

installation. Concrete masonry should be kept dry at the job site, or the potential for shrinkage cracking in the wall will increase.

Portland cement-lime mortars generally produce higher flexural bond strengths and are therefore more resistant to water penetration. Type N mortar has a lower cement content and higher lime content than Type S and therefore experiences less shrinkage cracking and bond separations. Unit texture, mortar workability, water retention, and extent of bond are also important, though, and workmanship probably affects water penetration resistance of mortar joints as much as anything else.

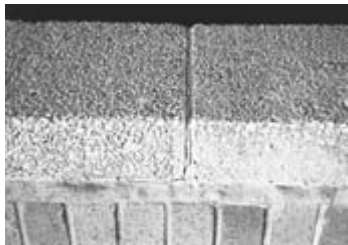


Figure 9-50 Rake out mortar joints in masonry copings and fill with bond breaker tape and elastomeric sealant to prevent water penetration through shrinkage cracks in mortar joints.



Figure 9-51 Brick rowlock copings have a high probability of cracking.

9.4.4 Waterproofing and Dampproofing

Below-grade masonry waterproofing generally consists of a bituminous membrane or other impervious film which is resistant to water penetration even under hydrostatic pressure. In areas where soil exhibits good drainage characteristics, the membrane may actually be only a dampproof layer designed to retard moisture until the water has drained away from the building by natural gravity flow (see Fig. 9-52). A commonly used protective measure consists of one, or preferably two, coats of cement mortar. This method is known as *pargeing*. Although parge coats will retard leakage, wall movements may cause cracks and permit moisture penetration. Impervious membranes with some elasticity offer better assurance against leaks.

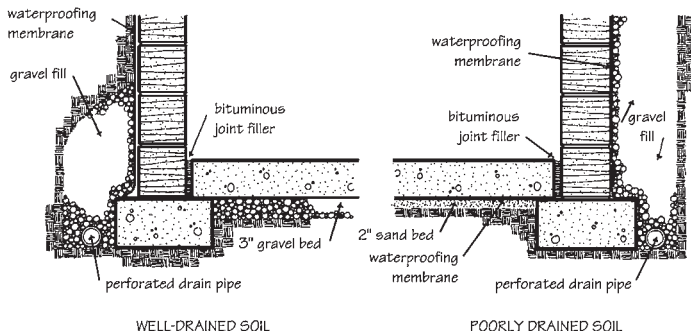


Figure 9-52 Below-grade waterproofing for masonry basement walls. (From BIA Technical Note 7.)

These may be fluid-applied bituminous products, elastomeric sheets, bentonite clay, or any tested and approved waterproofing system (see Chapter 13).

9.4.5 Condensation and Vapor Retarders

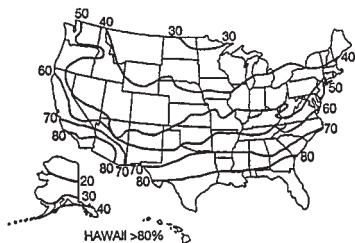
Differences in humidity between inside and outside air cause vapor to diffuse through a wall. A masonry wall that has absorbed moisture during a rain and is then warmed by solar radiation can have a temporarily elevated vapor drive. Even if rain has not penetrated to the wall cavity, this vapor drive can raise humidity levels enough to support mold growth on sheathing and framing materials. Condensation can cause wood framing members to warp or decay, metal to corrode and insulation to lose its effectiveness. Masonry can shrink or expand, effloresce, or suffer damage from freeze-thaw cycles.

Warm air has higher saturated vapor pressure than cool air. If separated by a wall, the higher-pressure vapor will migrate through the wall toward the lower-pressure atmosphere. During the winter this flow is from inside the building toward the outside. In warm, humid climates, this flow may reverse during the summer, with vapor traveling from the outside in. When vapor passes through a wall that is warm on one side and cool on the other, it may reach its dew point and condense into water within the wall. The temperature drop through a composite wall is directly proportional to the thermal resistance of the various elements. The drop in vapor pressure through the wall is in proportion to the vapor resistance of the constituent parts. Winter condensation problems are most frequent in insulated buildings of tight construction with occupancies or heating systems that produce high humidity. The relative humidity of the air within a building is increased by cooking, bathing, washing, or other activities using water or steam. This rise in the moisture content of the air increases the vapor pressure substantially above that of the outdoor atmosphere, and tends to drive vapor outward from the building through any permeable materials in the enclosure.

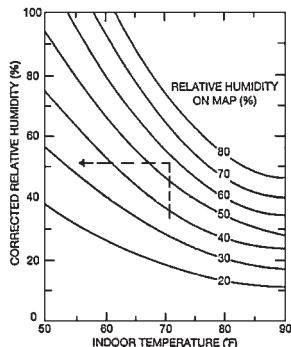
Tobiasson developed a graph to indicate areas of the United States where winter temperatures are cold enough to consider the use of a vapor retarder in roofs and wall assemblies (see Fig. 9-53). Summer condensation problems are most frequent in air-conditioned buildings in hot, humid climates along the Gulf of Mexico and the southeastern Atlantic coast. Warm, humid outdoor air diffuses through permeable materials in the building envelope and may reach its dew point if the temperature of the indoor air is cool enough. Tobiasson also developed a map indicating areas in which a vapor retarder may be needed to prevent summer condensation (see Fig. 9-54).

9.4.6 Calculating Condensation

The potential for condensation can easily be calculated if indoor and outdoor design temperatures and humidities are known, as well as the thermal and vapor resistances of the component wall materials. Saturated vapor pressures



indoor relative humidities above which buildings with an indoor temperature of 68°F need vapor retarders to prevent winter wetting of the building envelope



mapped relative humidity correction graph for indoor temperatures other than 68°F

Figure 9-53 Recommendations for use of vapor retarders to prevent winter condensation. (From Tobiasson and Harrington, Vapor Drive Maps of the U.S., 1985.)

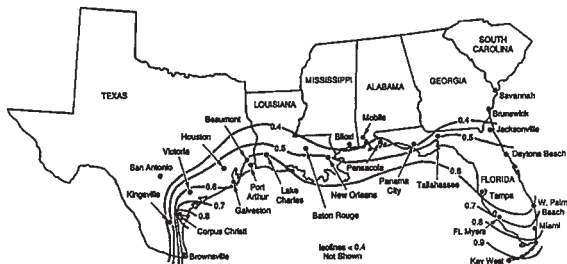


Figure 9-54 Vapor drive map for hot, humid climates. (From *Tobiasson, Vapor Retarders to Control Summer Condensation, 1989.*)

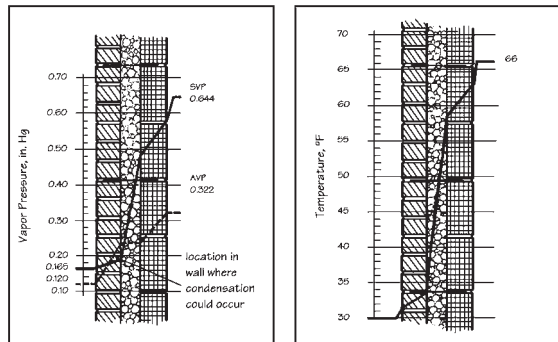
are determined for the indoor and outdoor temperatures, and the actual vapor pressures calculated as a percentage based on relative humidity conditions [i.e., saturated vapor pressure (SVP) \times relative humidity (RH) = actual vapor pressure (AVP)]. The difference between the indoor and outdoor AVP is called the *vapor pressure differential*. Vapor moves from the warm, higher-pressure atmosphere to the cool, lower-pressure atmosphere. During winter, this is normally an outward movement; during summer, an inward movement.

Using the thermal resistance of each material in the wall, a temperature gradient through the section is established, and the SVP at each temperature layer is listed. Using the vapor resistance of each material, the AVP at each layer can then be determined. At any location in the wall where actual vapor pressure exceeds saturated vapor pressure, condensation will occur.

Figure 9-55 show a sample calculation and graphic analysis for one set of conditions. In this particular case, condensation will occur at the cavity face of the exterior brick wythe, where it can do little damage. A vapor retarder on the cavity face of the interior wythe or on the interior wall surface will all but eliminate vapor diffusion to the cavity, and therefore reduce the risk of condensation. Every wall must be analyzed individually, because changes in materials or in temperature/humidity conditions change the location of the dew point. If condensation is expected to occur in masonry cavity or veneer walls, it should be designed to occur at the drainage cavity rather than in the masonry itself, where saturation might lead to freeze-thaw damage or efflorescence.

It is obvious that the introduction of vapor retarders within a wall assembly must be studied carefully to avoid trapping moisture in an undesirable location. Regional climatic conditions and the resulting direction of vapor flow must be analyzed and condensation points determined for both summer and winter conditions. If the flow of vapor is impeded by a highly vapor-resistant material on the warm side of the wall, the vapor cannot reach that point in the wall at which the temperature is low enough to cause condensation. Each design condition must be analyzed individually to determine the need and location for a vapor retarder within the wall assembly.

The infiltration and exfiltration of air through cracks and openings in a wall moves substantially higher quantities of moisture vapor (see *Fig. 9-56*). In high-rise buildings, air leakage rates are increased by the stack effect—



Material	Thermal Analysis				Vapor Analysis				
	R	%	ΔT	$^{\circ}F$	SVP	Rep	%	ΔV	AVP
Inside air temperature				66	0.644				0.322
Inside air film	0.68	9	3	63	0.580				0.322
4-in. unglazed facing tile	1.11	14	5	58	0.486	0.678	40.5	0.082	0.240
2-1/2 in. vermiculite insul.	5.50	70	25	33	0.188	0.016	1.0	0.002	0.238
4-in. brick	0.44	5	2	31	0.172	0.977	5.5	0.118	0.120
Outside air film	0.17	2	1	30	0.165				0.120
Outside air temperature				30					0.120
Total	7.90	100	36			1.671		0.202	

R = R-value
 ΔT = temperature difference ($^{\circ}F$)
 SVP = saturated vapor pressure (in.Hg)
 Rep = vapor resistance (1/perm)
 ΔV = vapor pressure difference (in.Hg)
 AVP = actual vapor pressure (in.Hg)

Figure 9-55 Sample condensation analysis. (From BIA Technical Note 7D.)

the inward movement of cool air at lower stories and outward movement of warm air at upper stories due to vapor pressure differentials. Seasonal patterns of efflorescence or dampness near the tops of buildings can be evidence of significant air leakage. Cracks between the backing wall and columns, slabs, or cross walls can provide paths for moisture-laden air to move back and forth between the wall cavity and the building interior. Perimeter sealant joints can provide air barriers at such locations. Building wrap materials are vapor-permeable air barriers which stop the airborne transmission of vapor but do not prevent the wall from “breathing” or drying out.

9.4.7 Coatings

In walls of solid masonry or single-wythe construction, greater care must be taken to avoid trapping moisture. Protective coatings are often used to prevent

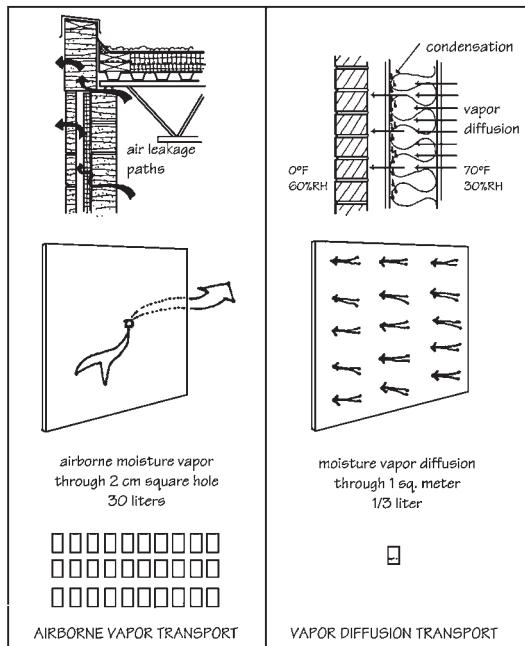


Figure 9-56 A much larger quantity of water vapor is transported through the building envelope by air leaks than by diffusion. (From R. L. Quirouette, *The Difference between a Vapor Barrier and an Air Barrier*, National Research Council of Canada, Ottawa, 1985; and *Canadian Homebuilder's Association, Builder's Manual*, CHBA, Ottawa, 1994.)

surface-water absorption in concrete masonry water penetration. Some paint films and various other coatings are impervious to vapor flow and, if placed on the wrong side of the wall, can trap moisture inside the masonry unit. Local climatic conditions must be evaluated in determining the direction of vapor flow.

Applied coatings must be carefully selected on the basis of their permeability. Inadvertent use of an impermeable or low-permeance surface finish on the cold side of a wall can create problems that are difficult and expensive to correct. A heavy paint film will prevent some rainwater from entering a wall but, more significantly, it will impede the escape of moisture entering the wall from other sources. Water may enter through pores in materials, partially filled mortar joints, improperly flashed copings, sills, parapet walls,

defective sealant joints and so on, through capillary contact with the ground, or through any number of other means. Moisture escapes from a wall in only two ways: (1) through continuous cavities with flashing and weep holes, and (2) by evaporation at the wall face (breathing). Low-permeance coatings (or a buildup of multiple coating layers) may blister or delaminate from both interior and exterior surfaces under certain circumstances (see Fig. 9-57).

There are numerous types of paint suitable for masonry walls, including cement-based paints, water-thinned emulsions, fill coats, solvent-thinned paints, and high-build textured acrylic coatings. In selecting a paint finish system, there are several things to consider. Paint products that are based on drying oils may be attacked by free alkali from the units or mortar. Alkaline-resistant paints and primers are recommended to prevent this, or the masonry must fully cure before painting. Surface conditions must also be considered, and preparations suitable to the selected finish made. Efflorescence must be removed from a masonry surface and observed for recurrence prior to painting. New masonry must not be washed with acid cleaning solutions if paint is to be applied. If low-alkali portland cement is not used in the mortar, it may be necessary to neutralize the wall with a 2- to 3½-lb/gal solution of zinc chloride or zinc sulfate and water. Existing masonry must be cleaned of dirt, mold, moss, mildew, and other contaminants. Walls must be wetted before any cleaning solution is applied, and thoroughly rinsed afterward to prevent unfavorable paint reactions or chemical contribution to efflorescence.



delamination of
exterior coating



delamination of
interior coating

Figure 9-57 Vapor permeance of coatings affects moisture movement through walls and can inhibit evaporation or the wall's ability to "breathe."

Stucco can be used to reduce the permeability of old and new masonry walls, and is a popular finish on concrete block. A two-coat application of portland cement stucco may prove to be the most economical and satisfactory method for treatment of leaky walls where repointing and exterior wall treatment costs would be excessive. Good bond between the stucco and masonry depends on mechanical key and suction, and the texture of concrete masonry provides an excellent substrate. Lime may be added to the cement-sand mixture for plasticity, but should not exceed 10% by weight or 25% by volume of the cement. Total thickness of the stucco application should be a minimum of $\frac{1}{2}$ in. Walls that are not reinforced against shrinkage and movement cracks can transmit excessive tensile stresses to monolithic stucco coatings and cause cracking of the finish surface as well.

Clear water repellents are often advertised as a cure-all for masonry moisture problems, and they are often incorrectly referred to as “sealers” or “waterproof” coatings—which they are not. Water repellents generally change the capillary angle of pores in the face of the masonry to repel rather than absorb water, but they will not bridge hairline cracks or separations at the mortar-to-unit interface. Clear water repellents can reduce absorption through the face of the masonry and prevent soiling on light-colored units while still permitting the wall to breathe.

There are three types of clear water repellents: stearates, acrylics and silicones. No single type is equally suitable or effective on all masonry substrates, because the physical and chemical properties of clay brick, concrete masonry, and stone vary so widely. Compatibility of substrate and surface treatment should always be evaluated on an individual basis.

Stearates, acrylics, and some silicone resins form a protective film on the masonry surface through resin deposition. The percent of solids content varies and should be selected on the basis of the porosity of the substrate to which it will be applied. A dense material treated with a high-solids compound will have a greatly reduced moisture vapor transmission (MVT) rate and will not breathe properly. Conversely, a porous material treated with a low-solids compound will not repel moisture effectively. Stearates and modified stearates generally have about 5% solids and are used for dense clay brick and stone surfaces. Acrylics range from 7.5% to 25% solids and are more suitable for concrete masonry. All acrylics will darken the masonry and change the natural matte finish. When solids exceed 10%, acrylics will leave a noticeable glossy sheen on the surface.

The most widely used water repellents are silane and siloxane compounds, which impregnate the masonry surface and react chemically with water to form silicone resins. Although the extremely small molecular structure permits penetration to a depth of about $\frac{1}{8}$ in., the substrate pores are not completely blocked, so moisture vapor transmission remains high. Silanes and siloxanes also rely on a chemical bond to silicate minerals in the masonry, so they are not appropriate for application to limestone and marble. Silanes require the catalytic action of substrate alkalis to form the active silicone resin, so they are not appropriate on clay brick or natural stone. Siloxanes, on the other hand, are polymerized compounds which react independent of the substrate composition. Some proprietary water repellents are blends of silane, siloxane, stearates, and other compounds.

Many manufacturers currently market concrete masonry units made with an integral water-repellent admixture. The mortar used with these units must also be treated with an integral water-repellent admixture, but no integral or field-applied water repellent, regardless of its chemical composition, will solve the problems of poorly designed or constructed masonry

walls. Water repellents and other coatings are not a substitute for flashing and weep hole systems in cavity wall or single-wythe designs. If a surface treatment is determined to be desirable on repair or renovation projects, defects such as leaky copings and roof flashing, defective sealant joints, and hairline cracks at the mortar-to-unit interface must be corrected before the treatment can be applied. Efflorescence must also be removed and the source of water which caused it found and repaired before applying either surface coating or penetrating treatments. Even though the moisture vapor transmission rate of the wall may be relatively unaffected by water repellents, if the masonry is efflorescing and the source of moisture has not been addressed, concealed interstitial salt crystals may be formed within the masonry. The partially obscured capillary pores allow moisture to evaporate through the surface, but block the natural escape of the salts, which are deposited behind the treated area, where they recrystallize. The continuing action of this “subflorescence” gradually increases the salt concentration, and the expansive pressure of crystallization can be sufficient to spall the face of the masonry. Although a clear water repellent may initially appear to stop efflorescence, it may only be burying the problem below the surface.

Since water repellents cannot bridge even very small cracks, and since the primary path of moisture through the face of a masonry wall is through cracks, it is misleading to say that they “protect” the wall from moisture infiltration, as many manufacturers claim. Depending on individual substrates and conditions, clear water repellents can help shed water from the face of masonry walls, decrease the absorption of porous units, and protect the materials from staining and from excessive absorption of acid rain. They will not, however, “waterproof,” nor will they “seal” the surface. Water repellents, when used, should serve only as a single component of the total system design, and should never be relied upon as the first or only line of defense.

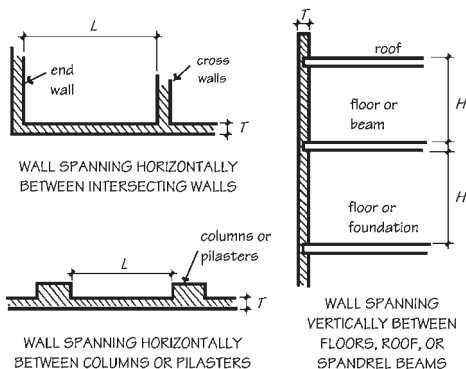
10

MASONRY WALLS AND VENEERS

The term “non-loadbearing” as it is used in masonry design means that the wall or element referred to does not carry the vertical compressive load of the structure. It may, however, be self-supporting and carry other applied loads from wind and seismic forces. Such non-loadbearing elements include partition walls, garden walls, shaft enclosures, fire walls, curtain walls, and veneers.

Code requirements for non-loadbearing walls are based on standards originally developed by the National Institute of Standards and Technology (NIST), the American National Standards Institute (ANSI), the Brick Industry Associations (BIA), and the National Concrete Masonry Association (NCMA). The design of unreinforced non-loadbearing masonry walls and partitions is governed by empirical lateral support requirements expressed as length- or height-to-thickness (h/t) ratios. The Masonry Standards Joint Committee (MSJC) *Building Code Requirements for Masonry Structures*, ACI 530/ASCE 6/TMS 402, and the *International Building Code* (IBC) both prescribe a maximum h/t of 36 for interior non-bearing walls and a maximum h/t of 18 for exterior non-bearing walls (see Fig. 10-1). Span limitations for bearing walls are discussed in Chapter 12.

Lateral support can be provided by cross walls, columns, pilasters, or buttresses, where the limiting span is measured horizontally, or by floors, roofs, spandrel beams, clips, angles or anchors, where the limiting span is measured vertically. Anchorage between walls and supports must be able to resist wind loads and other lateral forces acting either inward or outward. All lateral support members must have sufficient strength and stability to transfer these lateral forces to adjacent structural members or to the foundation. Arbitrary span limitations, of course, do not apply if the walls are designed by engineering analysis.



Empirical Span-to-Thickness Ratios for Lateral Support of Masonry Walls

Wall or Element	Maximum Unsupported Height or Length to Nominal Thickness (L/T or H/T)
Non-bearing walls	
exterior	18
interior	36

(Based on requirements of the MSJC Building Code Requirements for Masonry Structures ACI 530/ASCE 5/TMS 402, and International Building Code 2003)

Figure 10-1 Lateral support requirements for empirically designed non-loadbearing masonry walls and partitions.

10.1 INTERIOR PARTITIONS

Partitions are interior, non-loadbearing walls one story or less in height, which support no vertical load other than their own weight. They may be separating elements between spaces, as well as fire, smoke, or sound barriers.

Based on an h/t ratio of 36 as prescribed in the IBC and MSJC codes, a single-wythe, 4-in. brick partition without reinforcing steel is limited to a 12-ft span, while a 6-in. brick partition can span 18 ft between supports, and an 8-in. hollow brick partition 24 ft. If the partition is securely anchored against lateral movement at the floor and ceiling, and if the height does not exceed these limits, there is no requirement for intermediate walls, piers, or pilasters along the length of the partition. If additional height is required, the 8-in. hollow brick can be reinforced every 24 ft, or pilasters can be added at 12- or 18-ft intervals for the 4-in. and 6-in. walls, respectively. Lateral support is required in only one direction and can be either floor and ceiling anchorage (see Fig. 10-2) or cross walls, piers, or pilasters, but need not be both.

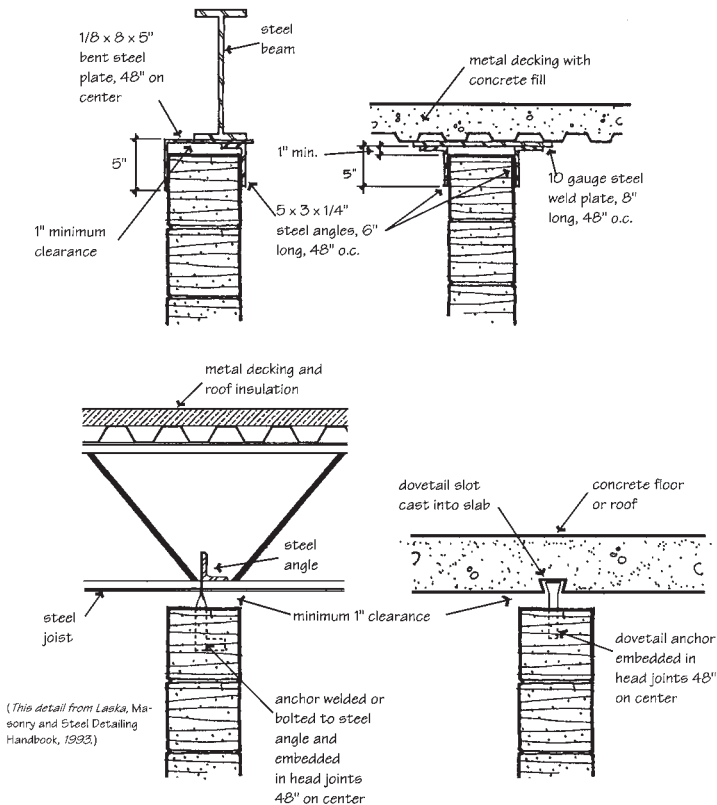


Figure 10-2 Examples of lateral support at the tops of interior, non-loadbearing partitions.

Structural clay tile is often used for partitioning in schools, hospitals, food processing plants, kitchens, sports facilities, airports, correctional facilities, and so on, where the imperviousness of a ceramic glazed surface, high durability, and low maintenance are required. Several different types of wall construction may be used, depending on the aesthetic requirements for the facing. For the standard 4-, 6-, and 8-in. thicknesses, single units glazed on

one or both sides are available. Double wythes can be used to provide different colors or finishes on each side of the partition (see Fig. 10-3). The 6- and 8-in. walls are capable of supporting superimposed structural loads, but the 4-in. partitions are limited to non-loadbearing applications. Lateral support spacing is governed by the same length- or height-to-thickness ratio of 36, giving the same height limitations of 12, 18, and 24 ft without pilasters or cross walls.

Concrete block partitions are widely used as interior fire, smoke, and sound barriers. Decorative units can be left exposed, but standard utility block is usually painted, textured, plastered, or covered with gypsum board. Wood or metal furring strips can be attached by mechanical means as described in Chapter 7, or sheet materials may sometimes be laminated directly to the block surface. Code requirements for lateral support are the same as for brick and clay tile.

Hollow masonry unit partitions can be internally reinforced to provide the required lateral support in lieu of cross walls or projecting pilasters (see Fig. 10-4). A continuous vertical core at the required interval is reinforced with deformed steel bars and then grouted solid to form an in-wall column.

Cavity walls can be similarly reinforced and also facilitate the placement of conduit and piping for utility distribution within a building. The continuous cavity easily accommodates horizontal runs. The thickness of cavity walls for computing lateral support requirements is taken as the net thickness of the two wythes minus the width of the cavity.

10.2 SCREEN WALLS AND FENCES

Perforated masonry screen walls may be built with specially designed concrete block or clay tile units, with standard concrete blocks laid with cores oriented horizontally, with brick or block laid in an open pattern, or with combinations of these units (see Fig. 10-5). As sun screens, the walls are often built along the outside face of a building to provide shading for windows. Screen walls are also used to provide privacy without blocking air flow, and to form interior and exterior area separations. The function of the wall influences finished appearance, from strong and heavy to light and delicate. Dark colors absorb more heat and reflect less light into interior spaces. Relatively solid wall patterns block more wind, and open patterns allow more ventilation.

Screen walls can be anchored at the floor line or at vertical structural projections such as steel or masonry piers or pilasters (see Fig. 10-6). Screen walls are governed by the same h/t ratio for lateral support requirements as empirically designed masonry walls and partitions, but those with interrupted bed joints should be designed more conservatively because of reduced flexural strength and lateral load resistance.

Concrete masonry screen wall units should meet the minimum requirements of ASTM C129. Brick should be ASTM C216, Grade SW, and clay tile units should be ASTM C530, Grade NB. Mortar for exterior screen walls should be Type N or Type S.

Solid, uncored brick is used to build what some call “pierced” walls by omitting the mortar from head joints and separating the units to form voids. The walls may be laid up in single- or double-wythe construction. In double-wythe walls, separate header or rowlock courses alternate with stretcher courses to form different patterns. Double-wythe walls are more stable than single-wythe designs because of the increased weight, wider footprint, and through-wall bonding patterns. Piers may be either flush with the wall or

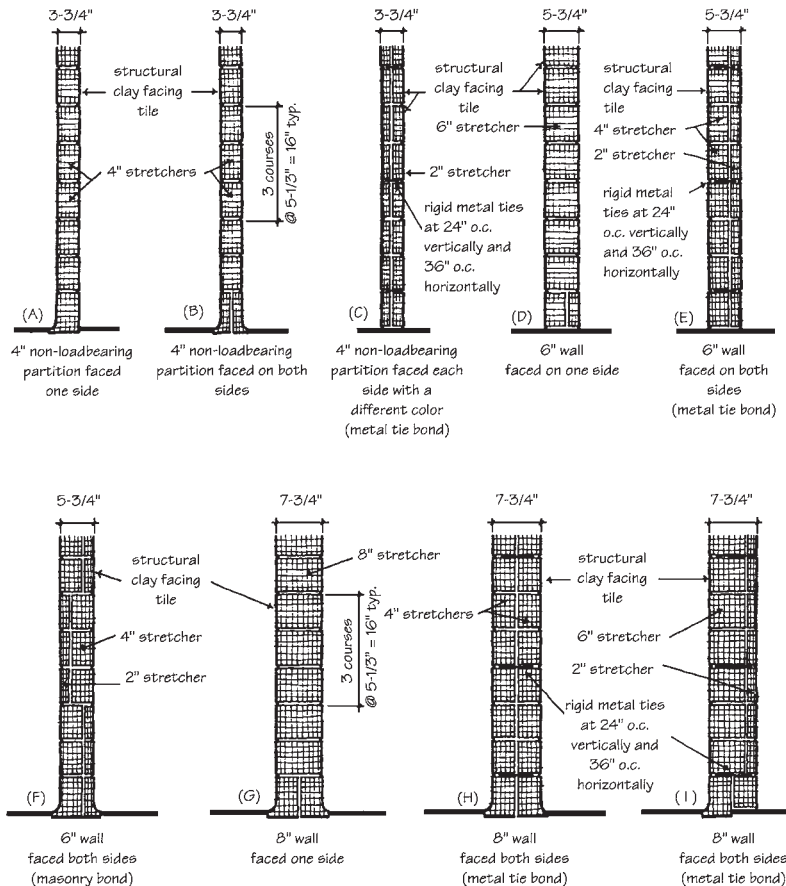


Figure 10-3 Non-loadbearing structural clay tile partitions can be faced on one or both sides and bonded with masonry headers or metal ties. (From BIA, Technical Note 22.)

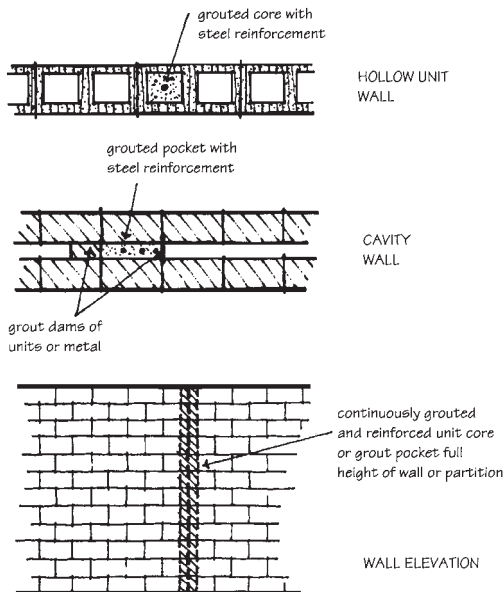


Figure 10-4 In-wall columns provide lateral support for empirically designed hollow unit masonry walls and cavity walls.

projecting on one or both sides. The coursing of the screen panels must overlap the coursing of the piers to provide adequate structural connection. Regardless of exact design, however, the pattern of units in a pierced wall must provide continuous vertical paths for load transfer to the foundation, and the bearing width of these paths or “columns” should be at least 2 in. (see Fig. 10-7).

Concrete screen block and clay screen tile are made with a decorative pattern of holes in the units, so it is not necessary to separate them with open head joints. Most unit types are designed to be laid with continuous vertical and horizontal mortar joints in stack bond patterns. The larger area of mortar bedding increases the lateral load resistance of the wall. The continuous bed joints accommodate the installation of horizontal joint reinforcement, and bond beam courses can be added at the top and bottom of the wall for even greater strength.

The NCMA has done considerable research on concrete masonry screen walls, and as a result, more is known about this type of unit strength and wall performance than any other type of screen wall. Units should have a minimum compressive strength of 1000 psi (gross) when tested with the

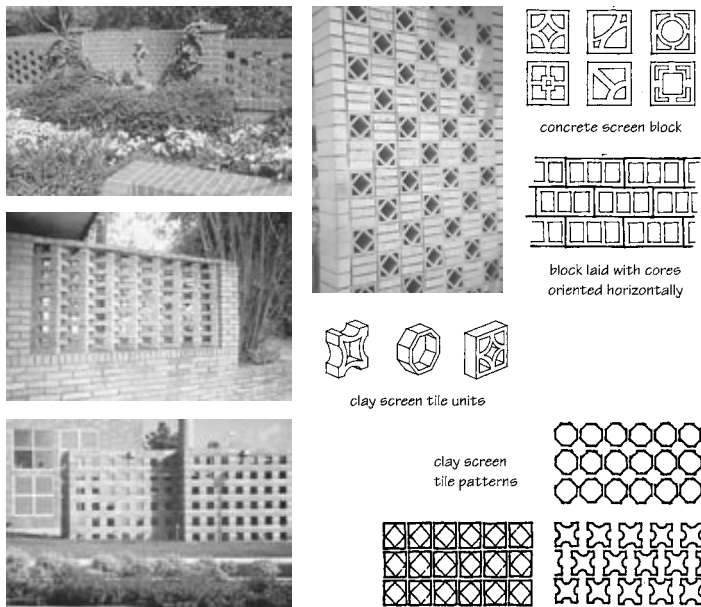


Figure 10-5 Examples of masonry screen wall units and bonding patterns.

cores oriented vertically, and face shells and webs should be at least $\frac{3}{4}$ in. thick. Type S mortar is recommended, and truss-type joint reinforcement spaced 16 in. on center vertically.

Lateral support for concrete masonry fences is usually provided by reinforced pilasters or by internal vertical reinforcement (see Fig. 10-8). Foundations should be placed in undisturbed soil below the frost line. For stable soil conditions where frost heave is not a problem, a shallow continuous footing or pad footing provides adequate stability. Where it is necessary to go deeper to find solid bearing material, where location in relation to property lines restricts footing widths, or where the ground is steeply sloping, a deep pier foundation provides better support. In each instance, the supporting pilaster is tied to the foundation by reinforcing dowels. A vertical control joint should be provided on one side of each pilaster support. Joint reinforcement in the panel sections should stop on either side of the control joint. The designs shown in Figs. 10-9 and 10-10 are based on wind loading conditions, but are not intended to resist lateral earth pressure as retaining walls. Concrete masonry fences require joint reinforcement and control joints for

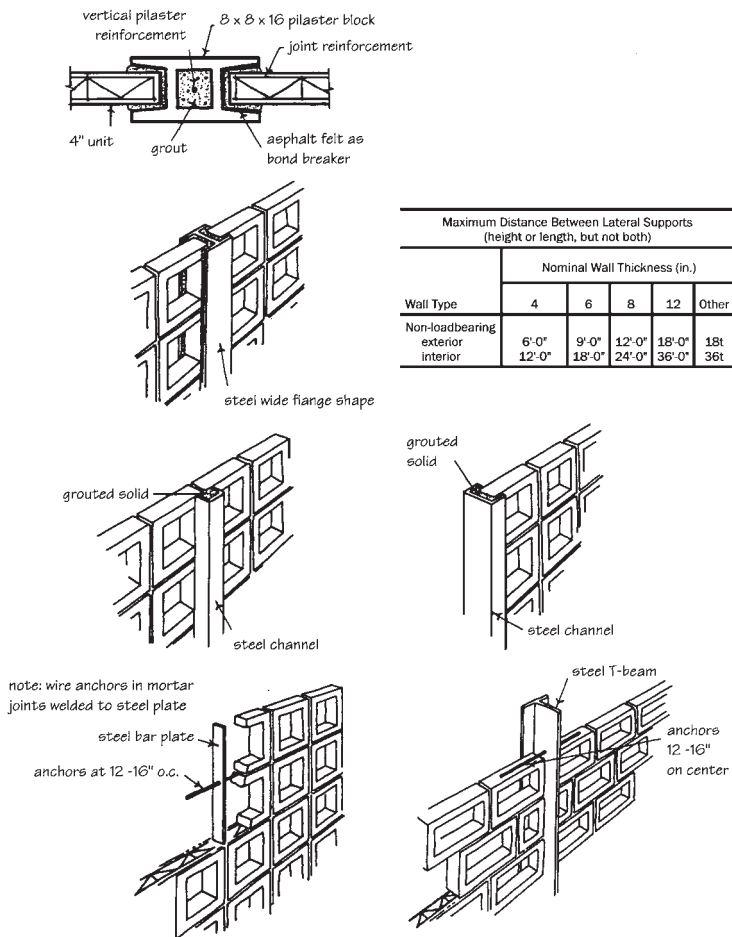


Figure 10-6 Methods of providing lateral support for masonry screen walls. (From *National Concrete Masonry Association, TEK Bulletin 5, NCMA, Herndon, VA.*)

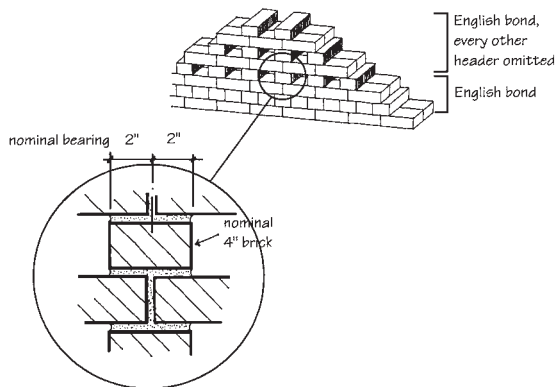


Figure 10-7 Minimum nominal unit bearing length for pierced brick screen walls.

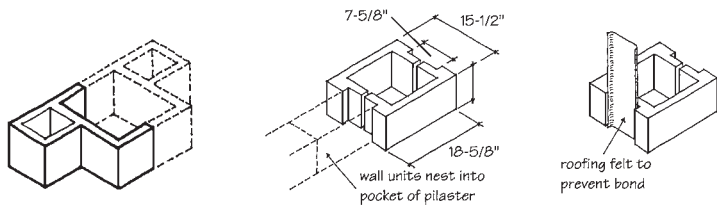
shrinkage crack control (see Fig. 10-11). Stucco may be applied directly to concrete masonry unit fences, with control joints in the same locations as the CMU control joints (see Fig. 10-12).

Brick fences may take a number of different forms. A straight wall without pilasters must be designed with sufficient thickness to provide lateral stability against wind and impact loads. A rule of thumb is that for a 10-lb/sq ft wind load, the height above grade should not exceed three-fourths of the square of the wall thickness ($h \leq \frac{3}{4} t^2$). If lateral loads exceed 10 lb/sq ft, the wall should be designed with reinforcing steel. Traditional brick fences are multi-wythe and bonded with brick headers laid in a variety of patterns (see Fig. 10-13). Fences laid in running bond pattern more commonly use metal ties to connect the two wythes (see Fig. 10-14). Heavier ties can be spaced farther apart than light-gauge wire or corrugated sheet metal ties. Several sizes and shapes of masonry-bonded and metal-tied pilasters are shown in Fig. 10-15.

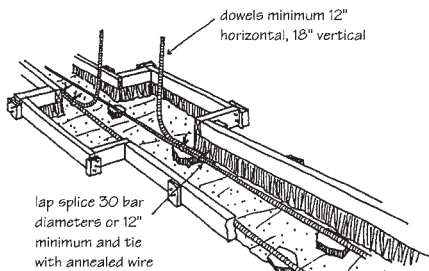
Brick “pier-and-panel” fences are composed of a series of thin panels (nominal 4 in.) braced intermittently by reinforced masonry piers (see Fig. 10-16). Reinforcing steel and foundation requirements are given in the tables in Fig. 10-17. Foundation diameter and embedment are based on a minimum soil bearing pressure of 3000 lb/sq ft. Reinforcing steel requirements vary with wind load, wall height, and span. Horizontal steel may be individual bars or wires, or may be prefabricated joint reinforcement, but must be continuous through the length of the wall with splices lapped 16 in.

Since the panel section is not supported on a continuous footing, it actually spans the clear distance between foundation supports, functioning as a deep wall beam (see Chapter 12). Masons build the sections on temporary 2×4 wood footings that can be removed after the wall has cured for at least 7 days.

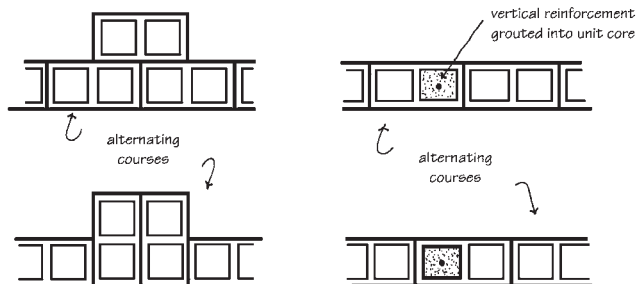
Serpentine walls and “folded plate” designs are laterally stable because of their shape. This permits the use of very thin sections without the need for



CMU PILASTER UNITS



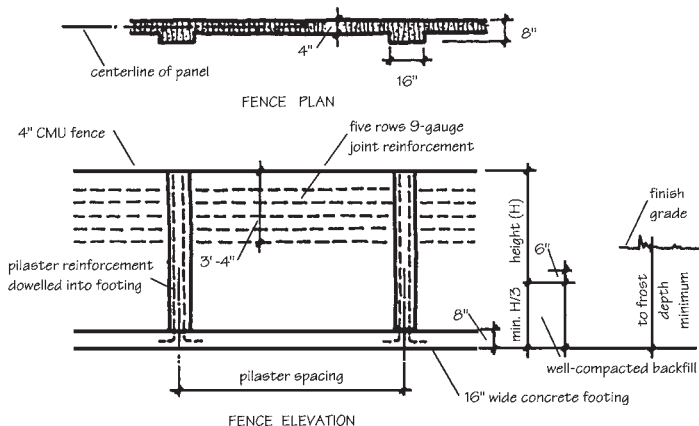
PILASTER REINFORCING (IF ANY) DOWELED INTO FOOTING



PILASTER MADE OF STRETCHER UNITS IN PROJECTED, INTERLOCKING BOND PATTERN

IN-WALL COLUMN IN REINFORCED VERTICAL CORE

Figure 10-8 CMU garden wall pilasters and in-wall columns.



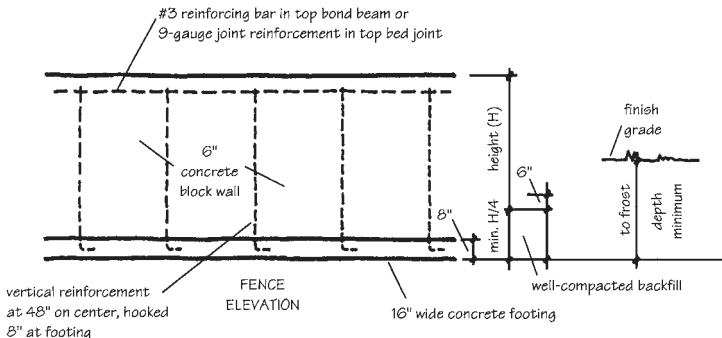
Pilaster Spacing for Wind Pressure					Pilaster Reinforcement for Wind Pressure			
5 psf	10 psf	15 psf	20 psf	H	5 psf	10 psf	15 psf	20 psf
19'-4"	14'-0"	11'-4"	10'-0"	4'-0"	1—No. 3	1—No. 4	1—No. 5	2—No. 4
18'-0"	12'-8"	10'-8"	9'-4"	5'-0"	1—No. 3	1—No. 5	2—No. 4	2—No. 5
15'-4"	10'-8"	8'-8"	8'-0"	6'-0"	1—No. 4	1—No. 5	2—No. 5	2—No. 5

Figure 10-9 Concrete masonry pier and panel fences. (From *Randall and Panarese, Concrete Masonry Handbook, 5th ed., Portland Cement Association, Skokie, IL, 1991.*)

reinforcing steel or other lateral support. For non-loadbearing walls of relatively low height, rule-of-thumb design based on empirically derived geometric relationships is used.

Since the wall depends on its shape for lateral strength, it is important that the degree of curvature be sufficient. Recommendations for brick and CMU walls are illustrated in *Fig. 10-18*. The brick wall is based on a radius of curvature not exceeding twice the height of the wall above finished grade, and a depth of curvature from front to back no less than one-half of the height. A maximum height of 15 times the thickness is recommended for the CMU wall, and depth-to-curvature ratios are slightly different. Free ends of a serpentine wall should be supported by a pilaster or short-radius return for added stability. Thicker sections and taller walls may be built if proper design principles are applied to resist lateral wind loads.

Masonry screen walls and fences must be supported by an adequately designed concrete footing to prevent uneven settlement or rotation. *Figure 10-19* shows rule-of-thumb sizes and proportions for both panel and pilaster sections. Where the ground under a screen wall or fence slopes slightly, the



H	Vertical Reinforcement for Wind Pressure			
	5 psf	10 psf	15 psf	20 psf
4'-0"	1—No. 3	1—No. 3	1—No. 4	1—No. 4
5'-0"	1—No. 3	1—No. 4	1—No. 5	1—No. 5
6'-0"	1—No. 3	1—No. 4	1—No. 5	2—No. 4

Figure 10-10 Reinforced concrete masonry fences without pilasters. (From *Randall and Panarese, Concrete Masonry Handbook, 5th ed., Portland Cement Association, Skokie, IL, 1991.*)

footing should be placed deeper in the ground at one end so that its entire length is level and below the frost line (see *Fig. 10-20A*). Where the ground slopes more steeply, both the footing and the fence must be stepped in a series of level sections, always keeping the bottom of the footing below the frost line (see *Fig. 10-20B*).

All free-standing masonry walls and fences, regardless of thickness, must be properly capped to prevent excessive moisture infiltration from the top. The appearance and character of a wall are substantially affected by the type of cap or coping selected, including natural stone, cast stone, metal, brick, or concrete masonry (see *Fig. 10-21*). The thermal and moisture expansion characteristics of the wall and coping materials should be similar. Control and expansion joint locations should be calculated (refer to Chapter 9), and joints should be tooled concave to compress the mortar against the face of the units, and decrease porosity at the joint surface. Copings should slope to shed water and should project beyond the face of the wall a minimum of $\frac{1}{2}$ in. on both sides to provide a positive drip and prevent water from flowing back under the coping. Through-wall flashing should be installed immediately below the coping to prevent excessive water penetration, and the coping then secured with metal anchors. Grouting of hollow

Control Joint Spacing for CMU Fences		
Joint Reinforcement Spacing (in. on center vertically)	Control Joint Spacing Expressed as Ratio of CMU Panel Length to Panel Height, L/H	Maximum Control Joint Spacing (ft.)
None	2	40
8	2-1/2	45
16	3	50
32	4	60

(From NCMA TEK Bulletin 10-1.)

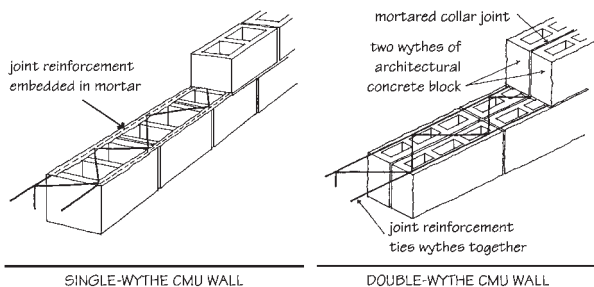


Figure 10-11 Joint reinforcement and control joint spacing for shrinkage crack control in single-wythe and multi-wythe concrete masonry fences.

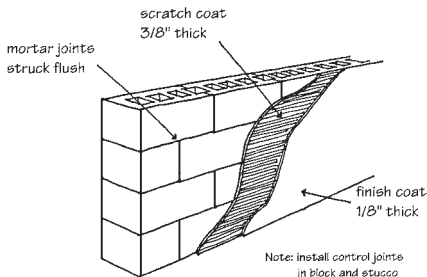


Figure 10-12 Direct two-coat plaster on concrete masonry.

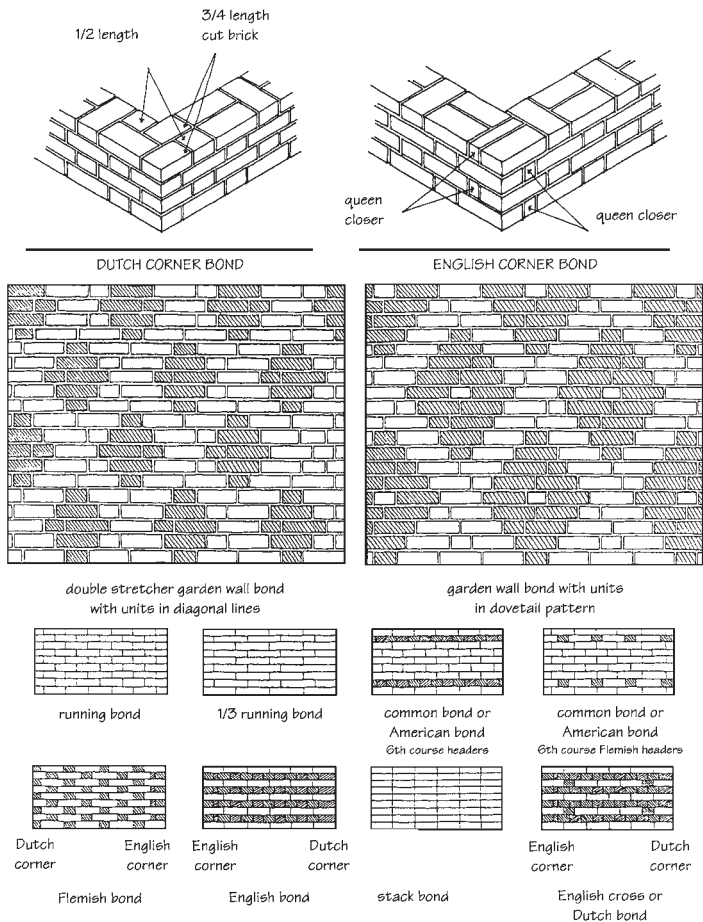


Figure 10-13 Traditional multi-wythe, masonry bonded brick fences.

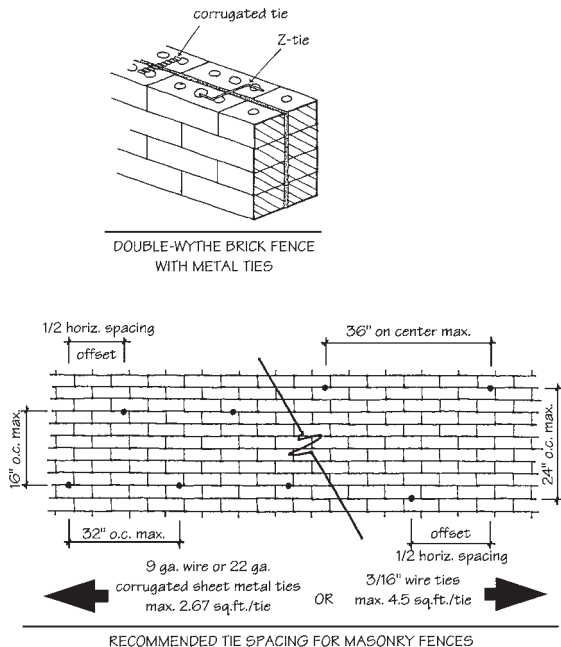
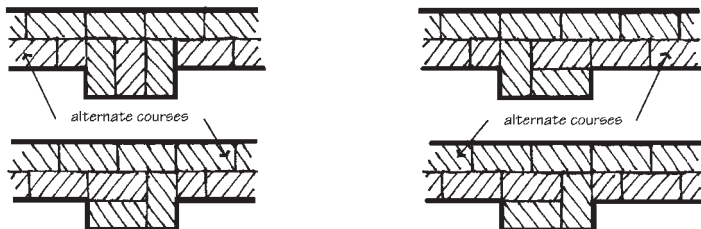


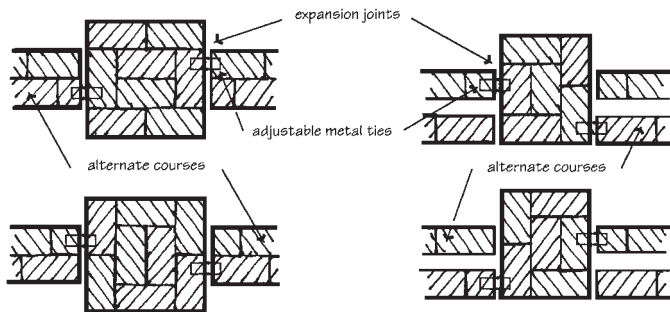
Figure 10-14 Multi-wythe masonry fences bonded with metal ties. (Based on veneer anchor spacing from International Residential Code for One- and Two-Family Dwellings, 2003.)

units, cavities, and hollow sections also increases the durability and strength of the wall by eliminating voids where water can accumulate and cause freeze-thaw damage or efflorescence. The combined use of masonry piers and metal fence panels should allow for differential thermal expansion and contraction between the two materials (see Fig. 10-22).

Natural stone is used to build free-standing dry-stack and mortared walls. *Dry-stack walls* laid without mortar are generally 18 to 24 in. wide and depend only on gravity for their stability. Trenches are dug to below the frost line, and if the ground slopes, may take the form of a series of flat terraces. A concrete footing may be poured in the trench, but walls are often laid directly on undisturbed soil. Two rows of large stones laid with their top planes slightly canted toward the center will provide a firm base. All stones placed below grade should be well packed with soil in all the crevices. Stones should be well fitting, requiring a minimum number of shims. A bond stone equal to the full wall width should be placed every 3 or 4 ft in each course to



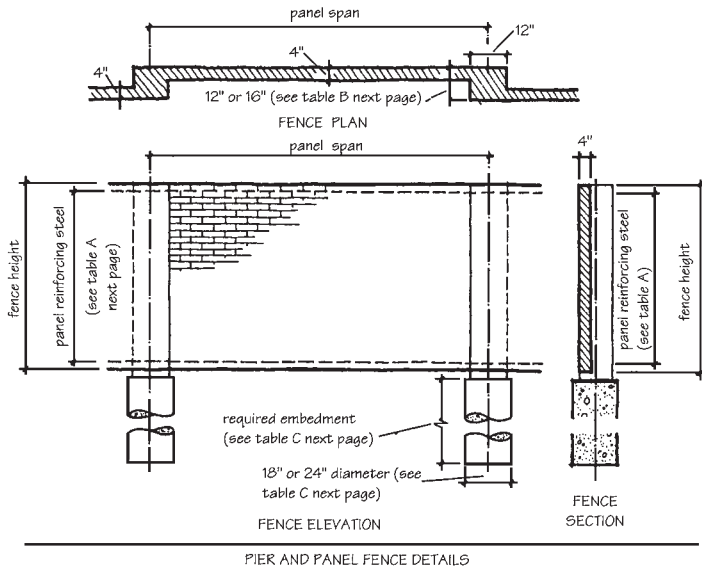
MASONRY-BONDED PILASTERS FOR TRADITIONAL MASONRY-BONDED BRICK FENCES



METAL-TIED PILASTERS FOR MULTI-WYTHE, METAL-TIED BRICK FENCES

Figure 10-15 Masonry-bonded and metal-tied pilasters for brick masonry fences. (Adapted from Harry C. Plummer, *Brick and Tile Engineering*, Brick Industry Association, Reston, VA, 1962.)

tie the inner and outer wythes together. All of the stones should be slightly inclined toward the center of the wall so that the weight leans in on itself (see Fig. 10-23). Greater wall heights require more incline from base to cap. Wall ends and corners are subject to the highest stress and should be built with stones tightly interlocked for stability. Relatively flat slabs of roughly rectangular shape work best for cap stones. The top course should be as level as possible for the full length of the wall. Large stones make dramatic walls and may be combined with smaller stone shims for stability (see Fig. 10-24).



ALTERNATE METHODS OF CONSTRUCTING PIERS
(see table B for reinforcing steel)

Figure 10-16 Single-wythe brick BIA pier and panel fences. (From BIA Technical Note 29A)

Mortared stone walls are laid on concrete footings poured below the frost line. Rubble stone or fieldstone walls are laid up in much the same way as dry-stack walls except that the voids and cavities are filled with mortar (see Fig. 10-25). Type S or Type N mortar should be used, and each course should be laid in a full mortar bed for maximum bond and strength. Building codes generally require that bond stones be uniformly distributed and account for no less than 10% of the exposed face area. Mortared rubble stone walls less than 24 in. thick must have bond stones at a maximum of 3 ft on center vertically and horizontally. For thicknesses greater than 24 in.,

TABLE A PANEL WALL REINFORCING STEEL

Wall span (ft)	Vertical Spacing* (in.)								
	Wind load 10 psf			Wind load 15 psf			Wind load 20 psf		
	A	B	C	A	B	C	A	B	C
8	45	30	19	30	20	12	23	15	9.5
10	29	19	12	19	13	8.0	14	10	6.0
12	20	13	8.5	13	9.0	5.5	10	7.0	4.0
14	15	10	6.5	10	6.5	4.0	7.5	5.0	3.0
16	11	7.5	5.0	7.5	5.0	3.0	6.0	4.0	2.5

*A, two - No. 2 bars; B, two - $\frac{3}{16}$ -in. diam wires; C, two - 9 gauge wires.

TABLE B PIER REINFORCING STEEL*

Wall span (ft)	Wind load 10 psf			Wind load 15 psf			Wind load 20 psf		
	Wall height (ft)			Wall height (ft)			Wall height (ft)		
	4	6	8	4	6	8	4	6	8
8	2#3	2#4	2#5	2#3	2#5	2#6	2#4	2#5	2#5
10	2#3	2#4	2#5	2#4	2#5	2#7	2#4	2#6	2#6
12	2#3	2#5	2#6	2#4	2#6	2#6	2#4	2#6	2#7
14	2#3	2#5	2#6	2#4	2#6	2#6	2#5	2#5	2#7
16	2#4	2#5	2#7	2#4	2#6	2#7	2#5	2#6	2#7

*Within heavy lines 12 by 16-in. pier required. All other values obtained with 12 by 12-in. pier.

TABLE C REQUIRED EMBEDMENT FOR PIER FOUNDATION*

Wall span (ft)	Wind load 10 psf			Wind load 15 psf			Wind load 20 psf		
	Wall height (ft)			Wall height (ft)			Wall height (ft)		
	4	6	8	4	6	8	4	6	8
8	2'-0"	2'-3"	2'-9"	2'-3"	2'-6"	3'-0"	2'-3"	2'-9"	3'-0"
10	2'-0"	2'-6"	2'-9"	2'-3"	2'-9"	3'-3"	2'-6"	3'-0"	3'-3"
12	2'-3"	2'-6"	3'-0"	2'-3"	3'-0"	3'-3"	2'-6"	3'-3"	3'-6"
14	2'-3"	2'-9"	3'-0"	2'-6"	3'-0"	3'-3"	2'-9"	3'-3"	3'-9"
16	2'-3"	2'-9"	3'-0"	2'-6"	3'-3"	3'-6"	2'-9"	3'-3"	4'-0"

*Within heavy lines 24-in. diam. foundation required. All other values obtained with 18-in. diam. foundation.

Figure 10-17 Brick pier and panel fences. (From BIA Technical Note 29A)

provide one bond stone for each 6 sq ft of wall surface. The minimum thickness of the wall must be sufficient to withstand all horizontal forces and the vertical dead load of the stone itself. For relatively low mortared walls, a thickness of as little as 8 in. may be adequate, but 12-in.-thick walls are more commonly used.

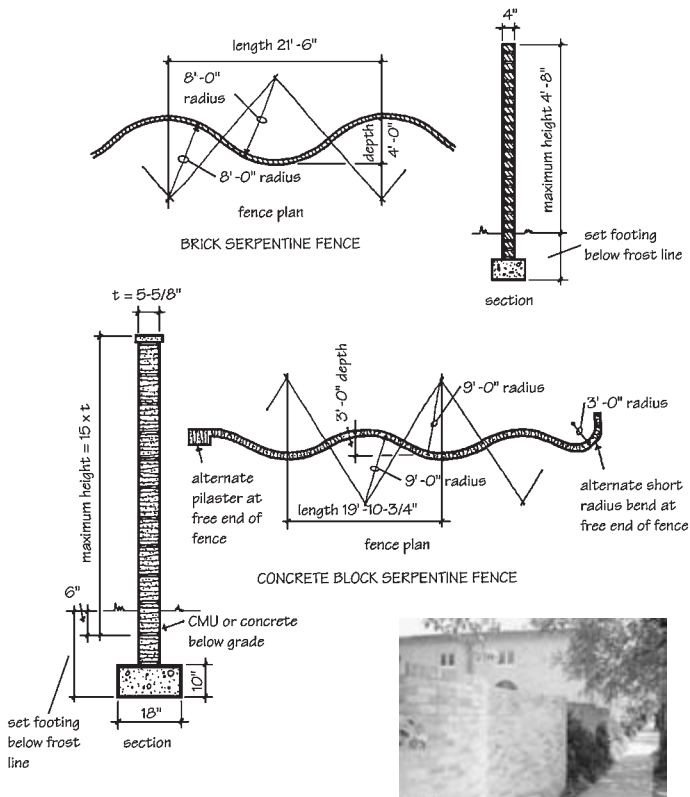


Figure 10-18 Serpentine fences. (From BIA Technical Note 29A and Randall and Panarese, Concrete Masonry Handbook, Portland Cement Association.)

10.3 GLASS BLOCK PANELS

Glass block is used in non-loadbearing interior and exterior applications, and is most often installed as single-wythe, stack bond panel walls. The compressive strength of the units is sufficient to carry the dead load of the material weight for a moderate height. Intermediate supports at floor and roof slabs require care in detailing to allow expansion and contraction of dissimilar materials (see Fig. 10-26). Deflection of supporting members above or below glass block panels should be limited to $L/600$. Movement joints at the perimeter of the panels should be at least $3/8$ to $1/2$ in. Glass blocks are

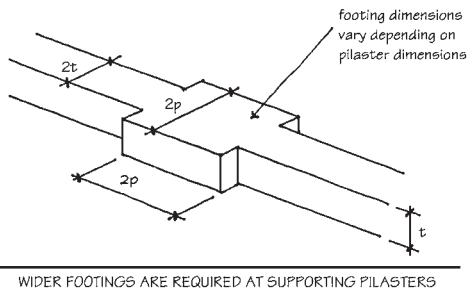
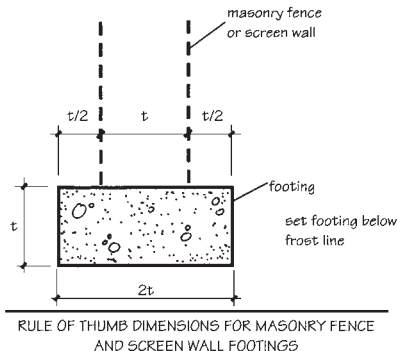
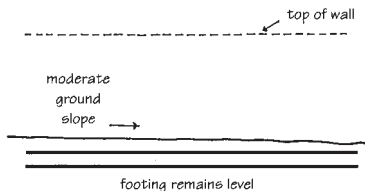


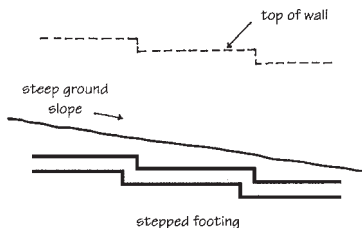
Figure 10-19 Footings for masonry fences and screen walls. (From Beall, *Masonry and Concrete for Residential Construction*, McGraw-Hill Complete Construction Series, McGraw-Hill, New York, 2001.)

normally laid in Type S or Type N cement-lime mortar, and bed joints are reinforced with ladder-type horizontal joint reinforcement spaced a maximum of 16 in. on center vertically. Since the bond between mortar and glass block is relatively weak, head and jamb recesses or channel-type supports are usually required to increase the lateral resistance of the panel section. If jamb recesses or channels are not provided in the adjacent wall, jamb anchors are required at a maximum spacing of 16 in. on center.

Size and area limitations for glass block wall panels prescribed by code are shown in *Fig. 10-27*. Whenever panels exceed code requirements for area limitations, they must be subdivided by metal stiffeners and/or supports (see *Fig. 10-28*). Vertical stiffeners should also be installed at the intersection of



(A) LEVEL FOOTING IN MODERATELY SLOPING GROUND

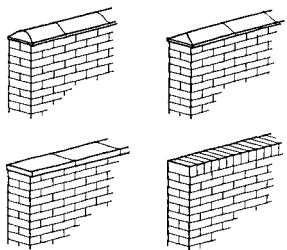


(B) STEPPED FOOTING IN STEEPLY SLOPING GROUND

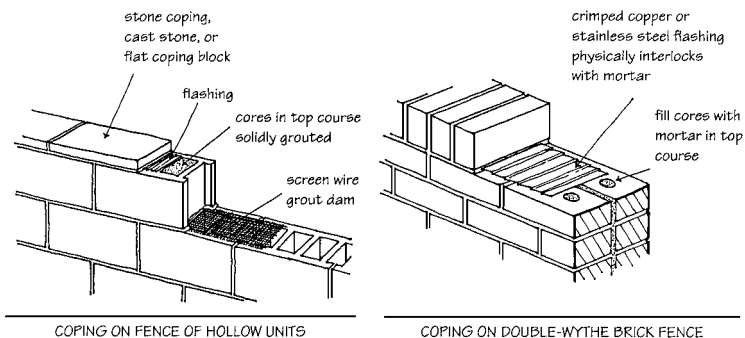
Figure 10-20 Footings for masonry fences and screen walls on sloping ground. (From Beall, *Masonry and Concrete for Residential Construction, McGraw-Hill Complete Construction Series, McGraw-Hill, New York, 2001.*)

curved and straight sections, and at every change in direction in multi-curved panels. All metal accessories, including joint reinforcement, jamb anchors, and stiffeners, should be hot-dip galvanized after fabrication in accordance with ASTM A153, *Standard Specification for Zinc Coating (Hot-Dip) on Iron or Steel Hardware*. Panels constructed of solar reflective block must be protected from runoff of rainwater from concrete, masonry, or metal materials located above the panel. Harmful substances may stain or etch the reflective block surface, so panels should be recessed a minimum of 4 in. and a drip provided at the edge of the wall surface above.

Using wedge-shaped head joints, panels can be curved at various radii depending on the size of the units. *Figure 10-29* shows the smallest achievable radius for each of four different block lengths. Ninety-degree corners may be laid to a corner post of wood or steel, or may incorporate special-shaped bullnose or hexagonal units (see *Fig. 10-30*).



DECORATIVE MASONRY WALL COPINGS



COPING ON FENCE OF HOLLOW UNITS

COPING ON DOUBLE-WYTHE BRICK FENCE

Figure 10-21 Copings and flashing for masonry screen walls and fences. (From Beall, *Masonry and Concrete for Residential Construction*, McGraw-Hill Complete Construction Series, McGraw-Hill, New York, 2001.)

10.4 SINGLE-WYTHE WALLS

Masonry curtain walls are designed to span horizontally or vertically between lateral connections without intermediate support. Horizontal curtain walls span across the face of columns or cross walls where they are connected for transfer of wind loads to the structure. Multi-story curtain walls are wholly supported at the foundation without intermediate shelf angles, and are connected only at the floors and roof for lateral load transfer. Masonry curtain walls can be designed by empirical methods or by engineering analysis. Empirical methods are governed by h/t ratios, but analytical design is not limited by such restrictions, so walls can be built to span multiple structural bays. Curtain walls may be single- or multi-wythe design, and may incorporate reinforcing steel to increase lateral load resistance or distance between lateral supports.

Most masonry curtain walls are single-wythe CMU. This is a popular exterior wall system for large steel-framed retail buildings, warehouses, sports facilities, and so on. Depending on the applications, the single-wythe



Figure 10-22 Allow for expansion and contraction of metal between masonry piers.

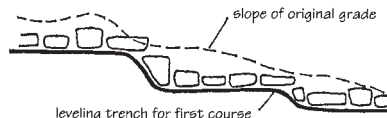
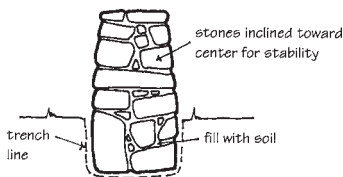


Figure 10-23 Dry-stack stone walls. (From Duncan, *The Complete Book of Outdoor Masonry*, TAB Books, Blue Ridge Summit, PA, 1978.)

walls may remain exposed on the interior, or metal studs and drywall may be added later. Where studs and drywall are used as an interior finish, they are independent of the masonry curtain wall and there are no anchors connecting the two. The masonry attaches to the structure only at the foundation, floors, roof, or columns. There is no drainage cavity per se, even though there may be a gap between the masonry and interior finish wall.

10.4.1 Empirical Design

Using empirical h/t ratios, an unreinforced 8-in. single-wythe hollow masonry curtain wall can be built 12 ft 0 in. high. This type of wall is often used for



Figure 10-24 Dry-stack wall with large and small stones.



Figure 10-25 Mortared stone walls.

single-story retail and warehouse construction over lightweight steel structural frames. Both hollow concrete block and hollow brick are used, depending on the aesthetic requirements of the project, but CMU is much more common. Lateral support connections at the roof line must be flexible to permit deflection of the structural frame independent of the masonry, as well as differential thermal and moisture movement between the various materials (see Fig. 10-31).

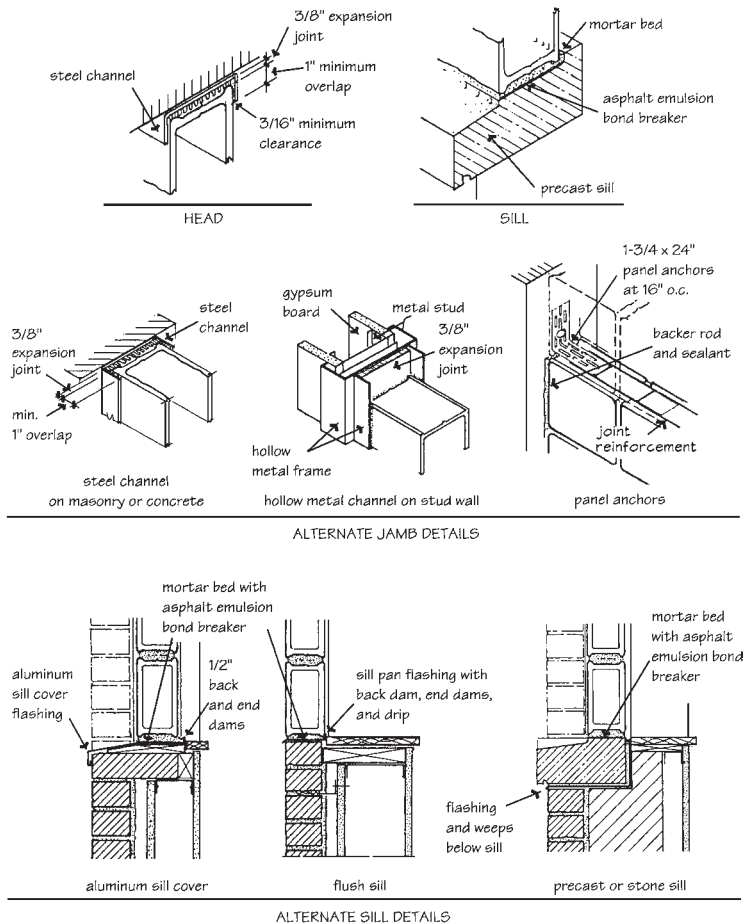
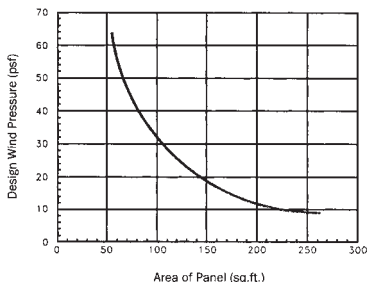


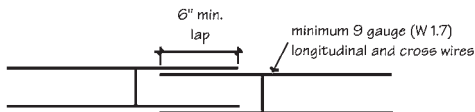
Figure 10-26 Typical glass block panel details.

Maximum Glass Block Panel Sizes						
Unit	Exterior Walls			Interior Walls		
	Area (sq. ft.)	Height (ft.)	Length (ft.)	Area (sq. ft.)	Height (ft.)	Length (ft.)
Standard, 3-7/8" thick	144 ¹	20	25	250	20	25
Thin, 3-1/8" hollow	85	10	15	150	20	25
Thin, 3" solid	85	10	15	100	20	25

¹ Maximum area limit for standard units is for 20 psf wind pressure. For other wind pressures, see graph below.



PANEL AREA ADJUSTMENTS FOR 3-7/8 IN. THICK STANDARD GLASS BLOCK UNITS FOR WIND PRESSURES OTHER THAN 20 PSF



JOINT REINFORCEMENT SPLICE DETAIL

joint reinforcement is required in bed joints at 16" on center, and in the first bed joint above and below openings

Figure 10-27 Code requirements for glass block panels. (Based on International Building Code 2003.)

10.4.2 Analytical Design

Masonry curtain walls which exceed allowable h/t ratios must be analytically designed, and may require reinforcing steel to resist flexural tensile stresses from either positive or negative wind pressures.

Long walls are usually designed to span horizontally between columns or cross walls, and must therefore resist bending and flexure in this direc-

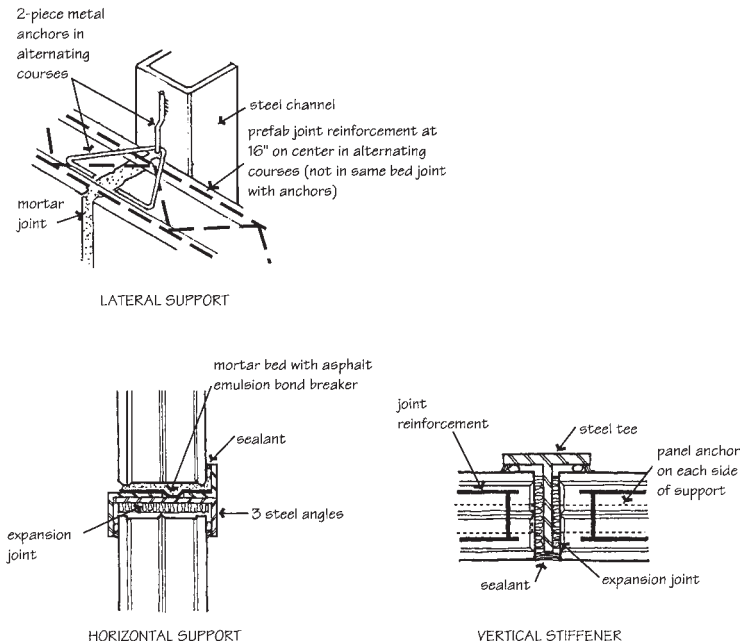
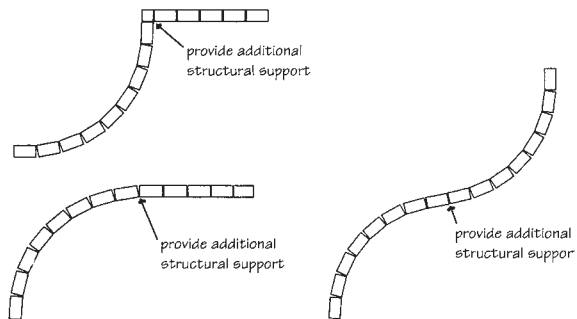


Figure 10-28 Glass block panel stiffeners and supports.

tion. Pilasters can also be used to stiffen curtain walls and increase the heights to which they can be built (see Fig. 10-32). For horizontal spans, only horizontal steel is generally required to provide adequate resistance. Walls that span vertically from floor to roof or multi-story walls that span several floors generally require vertical steel to resist bending and flexure in the vertical direction. For thin walls, additional load distribution is provided by anchorage to a backing wall of concrete, masonry, or stud construction, but there are no shelf angles supporting the masonry at each floor. Four-inch masonry veneers can even be designed as curtain walls supported only at the foundation. Engineering calculations generally must be submitted to demonstrate proper structural analysis, but the accommodation of differential movement is an equally critical element of the design.

10.4.3 Water Penetration Resistance

A single-wythe masonry wall, even when it is fully grouted and reinforced, may be susceptible to rain penetration. Good workmanship in tooling mortar



additional structural supports required at joint between curved and straight panels, and at inflection points of serpentine curves

(From Patterson, Illustrated 2000 Building Code Handbook.)

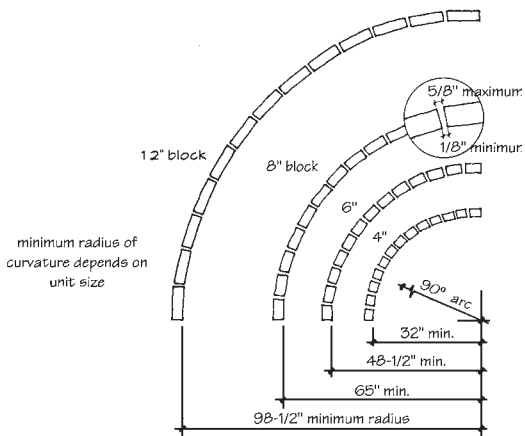


Figure 10-29 Curved glass block panels.

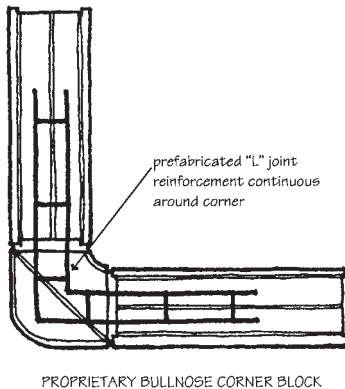
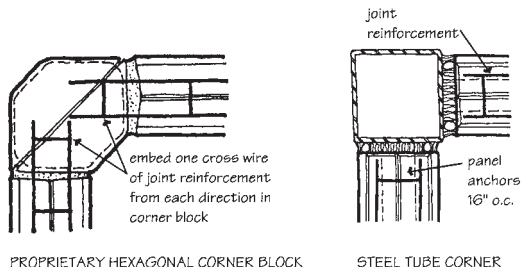


Figure 10-30 Glass block corner details.

joints, full mortar joints, and good bond between units and mortar will help in limiting the amount of water entering the wall, as will careful application of joint sealants around penetrations. Water-repellent admixtures in the block and mortar will reduce surface absorption, but they cannot stop the penetration of moisture through mortar joint bond line separations or other openings. Through-wall flashing at the top and bottom of the wall, at window and door heads, and at other wall penetrations is necessary to collect penetrated moisture so that it can be drained out through weep holes.

Through-wall flashing in a single-wythe wall breaks the mortar bond between courses, so vertical reinforcing steel is necessary for structural integrity even if it is not needed for load resistance. The steel is designed to resist all of the lateral load, without any reliance on mortar bonding at the bed joints. The most common method of flashing single-wythe walls is to step

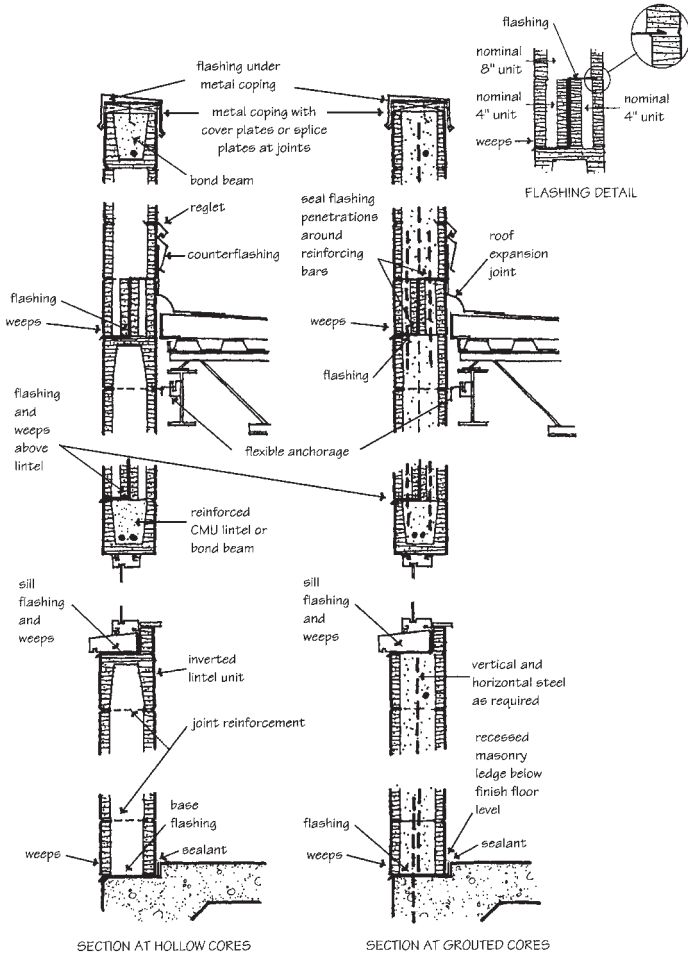


Figure 10-31 Single-wythe CMU curtain wall.

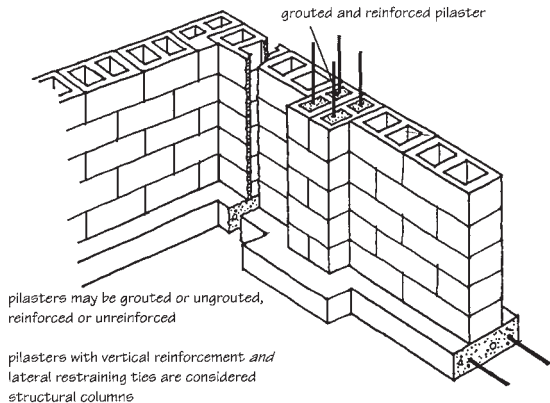
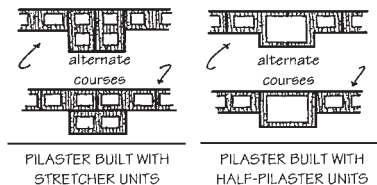


Figure 10-32 Single-wythe CMU wall pilasters.

a rubber membrane or sheet metal up between two half-thickness units at the flashing course (see Fig. 10-33). Penetrations at vertical reinforcing bars must then be sealed to maintain the integrity of the flashing.

Most of the water which penetrates single-wythe walls will flow downward through ungrouted cores to the flashing and weeps. Whenever there is excessive water penetration at the exterior wall face, there is the risk of water migrating across the unit webs and wetting the interior wall surface. Inadequate mortar bond and poor joint tooling workmanship can allow such excessive water penetration (see Fig. 10-34). Extra care is warranted in single-wythe walls because they lack the redundant protection of a true drainage cavity and are therefore less forgiving of design and construction errors. Water-repellent admixtures and field-applied water repellents cannot compensate for poor design or workmanship and should not be relied upon to prevent water penetration.

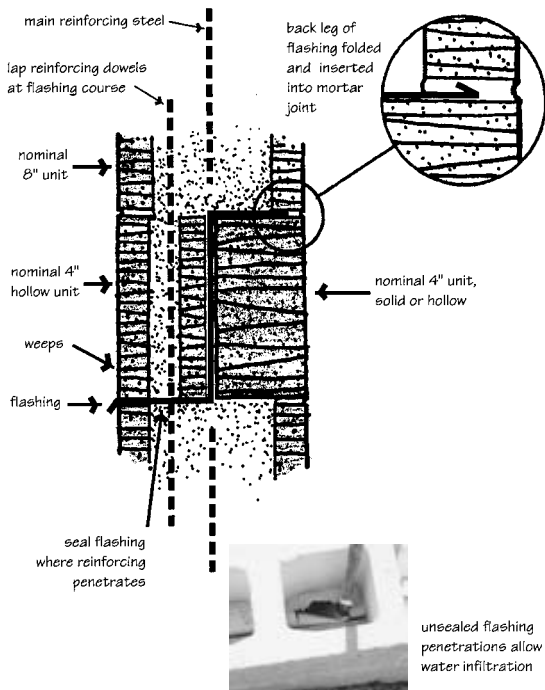


Figure 10-33 Vertical reinforcing steel is needed in single-wythe walls because flashing disrupts the mortar bond, but penetrations through the flashing must be sealed to prevent water infiltration.

10.5 MULTI-WYTHE WALLS

Multi-wythe masonry walls include both composite walls and cavity walls as described and illustrated in Chapter 8. Historic structures were generally built with loadbearing composite walls bonded with masonry headers. Composite walls today are usually only two wythes in thickness and are bonded with metal ties, but they are still typically loadbearing in application and much less commonly used than cavity walls. In cavity walls the backing and facing wythes are separated by an open drainage cavity for better protection against water penetration and connected with adjustable metal ties. Cavity walls may be either loadbearing or non-loadbearing. In loadbearing applications, the backing wythe typically supports axial loads from the floor and roof systems and the facing wythe supports only lateral wind loads and its own weight.

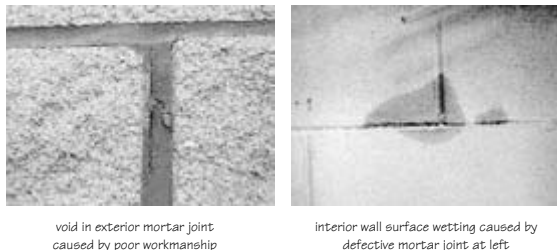


Figure 10-34 Neither water-repellent admixtures in the units and mortar nor multiple coats of field-applied water repellent can prevent this type of joint from leaking.

The IBC and MSJC Codes have stringent requirements for cavity wall ties. The two-piece adjustable ties of $\frac{3}{16}$ -in.-diameter (W2.8) wire must be spaced at a maximum of 16 in. on center vertically and horizontally, providing one tie for every 1.77 sq ft of wall area. Rigid rectangular or Z ties of $\frac{3}{16}$ -in.-diameter (W2.8) wire are permitted a maximum spacing of 24 in. on center vertically by 36 in. on center horizontally, with one tie for every $4\frac{1}{2}$ sq ft of wall area because the ties are stiffer than adjustable ties. Rectangular ties are for use with hollow masonry units, and Z ties for use with solid masonry units. Rigid ties should be limited to use in

- Cavity walls where the backing and facing wythes
 - Are of the same type of masonry with similar expansion and contraction characteristics
 - Are laid up at the same time
 - Are not separated by cavity insulation
 - Are constructed of units which course out at the same heights
- Multi-wythe walls grouted and reinforced so that backing and facing wythes react together under applied loads (i.e., composite walls)

When concrete masonry is used as the backing wythe in a cavity wall, the joint reinforcement required to control shrinkage cracking can be outfitted with adjustable ties to connect to a facing wythe of clay or concrete masonry. Three-wire joint reinforcement and joint reinforcement with fixed tab ties can also be used to connect the wythes of some types of cavity walls (see Chapter 7), but they do not provide as much flexibility for differential movement as adjustable ties. Spacing requirements for different types of wire ties are covered in Chapter 12.

10.5.1 Composite Walls

Because of the differential moisture shrinkage of concrete masonry and moisture expansion of clay masonry, contemporary composite walls most often consist of backing and facing wythes of the same material, that is, a concrete masonry backing with concrete masonry facing or a brick backing wall with a

brick facing. Composite walls may be laid with the backing and facing wythes separated only by a $\frac{3}{8}$ -in. or $\frac{3}{4}$ -in. collar joint which is filled with mortar as the wall is built. Most composite walls, though, are constructed with a wider space between the wythes, which can be grouted in low lifts as the wall is built or in high lifts after several courses or an entire story height is built (see Chapter 12 for grouting procedures). When the wythes of composite walls are laid contiguously, they may be bonded together by overlapping masonry headers or connected with rigid metal ties or metal joint reinforcement. Code requirements for spacing of masonry headers and metal ties are discussed in Chapter 12. Metal ties are less conducive to through-wall water penetration than masonry headers and are far more commonly used today, but composite walls of either kind are less resistant to rain penetration than cavity walls.

Composite walls resist rain penetration primarily by absorbing and storing moisture until it is evaporated back to the atmosphere. Like single-wythe walls, they are relatively unforgiving of design and construction errors because they too lack the redundant protection of a drainage cavity. For this reason, cavity walls are more suitable for exterior envelope applications. Composite walls can provide loadbearing capacity combined with finished masonry surfaces on both sides for interior applications (see Fig. 10-35).

10.5.2 Cavity Walls

Cavity walls are among the strongest and most durable of exterior building wall systems and are often the first choice for educational buildings, municipal buildings, government buildings, and others which will have a long service life. Although they may consist of brick backing and facing wythes or concrete masonry backing and facing wythes, cavity walls are most often constructed with concrete block as the backing wall and brick as the facing. The open cavity between the two wythes of masonry facilitates drainage of penetrated moisture when it is properly fitted with flashing and weeps. The wire ties used to connect the wythes are less prone to transferring moisture from the outer to inner surfaces than multi-wythe walls connected with masonry headers. Wire ties also create less thermal bridging than masonry headers, and the cavity between wythes can be partially filled with insulation for better overall thermal resistance and energy efficiency.

Two-piece adjustable ties permit differential thermal and moisture movements between the backing and facing wythes of a cavity wall. When constructed of dissimilar materials such as concrete and clay masonry, this differential movement can be significant. A concrete masonry backing wall experiences permanent moisture shrinkage as the latent moisture from the manufacturing process evaporates, and a clay masonry facing experiences permanent moisture expansion as the brick reabsorbs atmospheric moisture after it is fired (see Chapter 9). These opposing movements can be accentuated when cavity insulation increases the temperature differential between inner and outer wythes. Chapter 12 discusses the many ways in which masonry cavity wall wythes can be connected with adjustable ties. Regardless of the type of connector used, adjustable ties are limited to a maximum vertical offset of $1\frac{1}{2}$ in., and maximum play of $\frac{1}{16}$ in. (see Fig. 10-36).

In most areas of the United States, the exterior brick wythes of cavity walls should be constructed of Grade SW units, because the facing is isolated from the rest of the wall and therefore exposed to temperature extremes as well as driving rain. Type N mortar is suitable for most cavity wall construc-

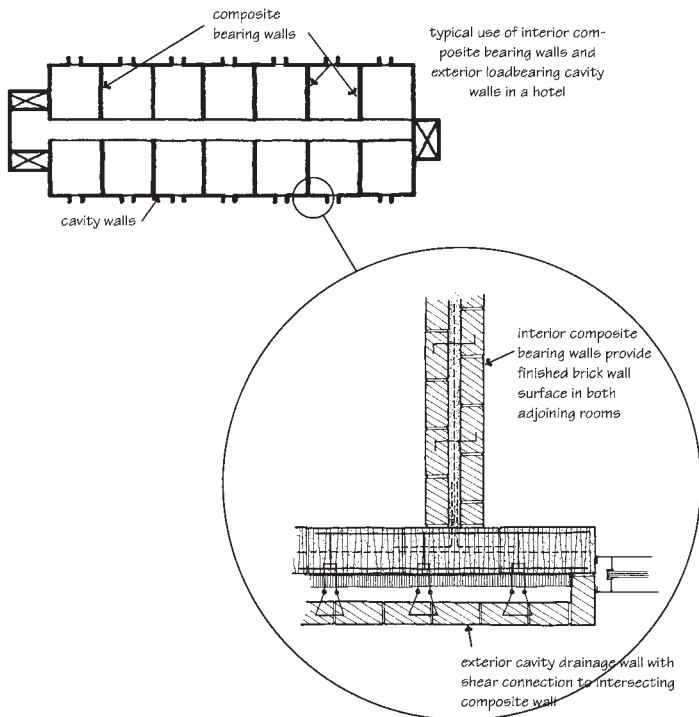


Figure 10-35 Example of interior loadbearing composite walls combined with exterior cavity walls.

tion (see Chapter 6 for mortar recommendations). Cavity walls should be protected against moisture penetration in accordance with the principles outlined in Chapter 9, relying primarily on a system of flashing and weep holes to collect and expel rain which enters through the facing wythe or moisture which condenses within the cavity. The CMU backing wall can be constructed as infill panels, as a curtain wall (see Fig. 10-37), or it can be constructed as a loadbearing wall. The cavity face of the concrete block backing should be coated with a dampproofing mastic to provide a water-shedding surface and to reduce air permeance through the CMU. The heads and sills of windows should be protected by flashing and sill pans to prevent moisture from migrating through glazing systems to the interior.

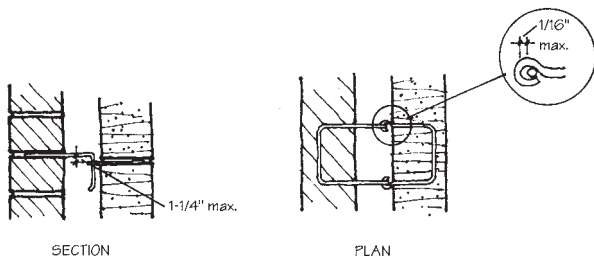


Figure 10-36 Maximum offset and play in adjustable metal cavity wall ties.

Periodic wetting and drying are not harmful to masonry or to the components which make up a cavity wall. Cavity walls are designed to collect and drain moisture efficiently so that there is no extended saturation which could cause efflorescence, freeze-thaw damage, or corrosion of metal ties. To maintain functionality, the cavity must be kept clear of mortar droppings and the flow of moisture to the weeps must be unobstructed. Despite the fact that moisture is designed to move through a masonry cavity wall in a controlled manner, mold growth cannot occur because there is no food source to sustain the proliferation of spores. Cavity walls are, in fact, more durable in resisting moisture damage than almost any other type of wall.

10.6 MASONRY VENEER

A veneer is defined as “a nonstructural facing attached to a backing for the purpose of ornamentation, protection, or insulation, but not bonded to the backing so as to exert a common reaction under load.” A non-loadbearing masonry veneer mechanically anchored to a loadbearing or non-loadbearing masonry backing wall is commonly referred to as a cavity wall even though the outer wythe of masonry technically functions as a veneer. Connectors used to attach masonry veneers to masonry backing walls are called ties. Connectors used to attach masonry veneers to non-masonry backing walls are called anchors. The term *veneer* is used to describe masonry cladding over non-masonry backing walls.

There are two basic methods of attaching masonry veneer. *Adhered veneer* is secured by adhesion with a bonding material to a solid backing. Adhered veneer does not support its own weight. *Anchored veneer* is secured by metal anchors attached to either a solid backing or a structural frame. The weight of an anchored veneer is typically supported by the structure or by shelf angles attached to the structure, at every floor. An anchored veneer may also be fully supported at the foundation without intermediate shelf angles. Unlike a reinforced curtain wall, an unreinforced veneer without shelf angles still requires lateral anchoring throughout its height to backing walls capable of transferring lateral loads to the structure.

10.6.1 Adhered Veneer

Adhesion attachment is normally limited to thin sections of terra cotta or stone facing. Codes limit the weight of the veneer to 15 lb/sq ft, 36 in. maxi-

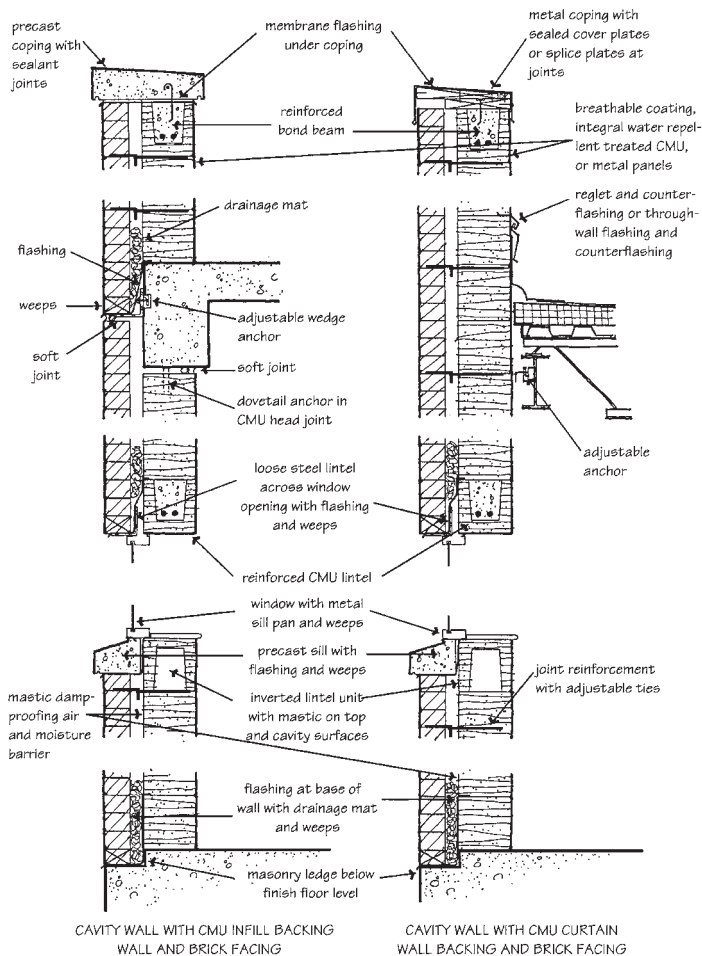


Figure 10-37 Basic cavity wall detailing.

mum face dimension, and 5 sq ft in area. The bond of an adhered veneer to the supporting element must be designed to withstand a shearing stress of 50 psi. Differential thermal and moisture movement characteristics should be considered in selecting backing and facing materials. An expanding clay masonry facing and a contracting concrete backup are not compatible when relying exclusively on an adhesive bond.

For fully adhered applications, a paste of portland cement and water is brushed on the moistened surfaces of the backing and the veneer unit. Type S mortar is then applied to the backing and to the unit, resulting in a mortar thickness of not less than $\frac{1}{2}$ in. or more than $1\frac{1}{4}$ in. If the surfaces are clean and properly moistened, the neat cement paste provides good bond to both surfaces, but a mechanical key formed by ribs or flanges on the back of the masonry helps support heavier units. Adhesion attachment is not common on wood or metal stud framing, but can be accomplished by first applying a scratch coat of cement plaster on metal lath over the studs.

Code requirements do not limit the length or height of adhered veneer except as necessary to control expansion and contraction. Any movement joints that occur in the backing or the frame must be carried through the bedding mortar and the veneer as well.

10.6.2 Anchored Veneer

Codes regulate the design of anchored veneers by prescriptive requirements based on empirical data. The veneer chapter of the MSJC Code limits use of the prescriptive design to walls subject to design wind pressures of 25 psf or less. Higher wind pressures require analytical design. Noncombustible, non-corrosive lintels of masonry, concrete, stone, or steel must be provided over openings, with deflections limited to $L/600$ of the span. Although codes require only a 1-in. clear cavity between the veneer and backing, the minimum recommended width of the open cavity between wythes of a cavity wall or between a veneer and its backing wall is 2 in. A narrower cavity is difficult for a mason to keep clear of mortar protrusions during construction (refer to Chapter 15). A 2-in. cavity width requires the use of wire anchors rather than the light-gauge corrugated sheet metal anchors typically used for residential construction. Corrugated anchors are not strong enough to span a cavity wider than 1 in. When rigid board insulation is to be installed in the cavity, the clear distance between the face of the insulation and the back of the facing wythe should also be 2 in. Codes limit the maximum distance between backing and facing to $4\frac{1}{2}$ in. This limitation is based on the stiffness and load transfer capability of wire ties and anchors. With a 2-in. open cavity, this would permit a maximum insulation thickness of $2\frac{1}{2}$ in.

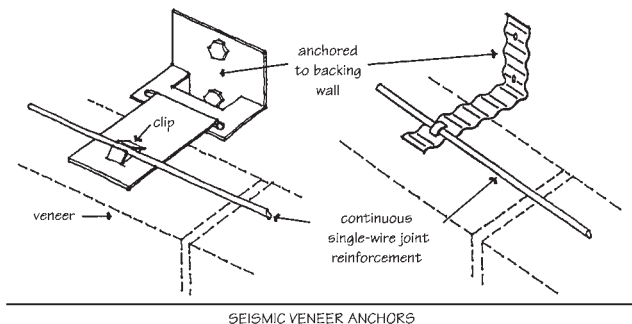
Empirical requirements limit the height permitted for anchored veneer. The MSJC Code has prescriptive requirements for every aspect of veneer design and construction (see *Fig. 10-38*), as well as special requirements for seismic areas (see *Fig. 10-39*).

The Brick Industry Association recommends, and some municipal building codes permit, anchored masonry veneer over concrete or masonry backing walls to be designed without shelf angles for heights of 100 ft. or more. Flexible anchorage to the backing walls permits differential movement and transfers wind loads to the structure throughout the height of the building. Proper detailing at parapets and other building elements is required to allow differential movement between the veneer and frame.

MSJC Prescriptive Requirements for Anchored Masonry Veneer	
Item	Minimum Requirements
Applicability	prescriptive requirements may not be used where basic wind speed exceeds 110 mph
Support	<p>must be supported on non-combustible foundations (i.e., concrete or masonry) except</p> <ul style="list-style-type: none"> may be supported on preservative-treated wood foundations to a maximum height of 18 ft. above the support may be supported on wood construction if veneer weighs 40 psf or less with a height of 12 ft. or less, deflection of supporting member from dead and live loads is limited to 1/600, masonry is not in direct contact with wood, and expansion joint is installed between veneer supported on wood and veneer supported on foundation when veneer is supported by floor construction deflection is limited to 1/600
Support over openings	unless the veneer is self-supporting (e.g., masonry arches), veneer above openings must be supported on non-combustible steel, concrete, or masonry lintels with minimum 4 in. bearing on each side and deflection limited to 1/600
Maximum height above non-combustible foundation	30 ft., with an additional 8 ft. permitted for gable ends, except if veneer with cold-formed steel stud backing exceeds this height, it shall be supported by non-combustible construction for each story above the height limit (unless designed by engineering methods)
Anchors	<ul style="list-style-type: none"> corrosion-resistant wire anchors not less than W 1.7 (9 gauge) with minimum 2 in. hook, or corrugated sheet metal not less than 7/8 in. wide with base metal thickness of 0.03 in. (22 gauge) and corrugations with a wavelength of 0.3 to 0.5 in. and an amplitude of 0.06 to 0.10, or adjustable anchors as above, or with pintles not less than W2.8 (3/16 in. diameter) with an offset not exceeding 1-1/4 in. and maximum clearance between connecting parts of 1/16 in., or joint reinforcement embedded in mortar joint (solid masonry units) or in mortar or grout (hollow masonry units) and extended into veneer wythe at least 1-1/2 in. with at least 5/8 in. mortar or grout cover to the exterior face maximum 1 in. between veneer and sheathing with corrugated anchors minimum 1 in. and maximum 4-1/2 in. between veneer and wood stud or framing with other anchors minimum bed joint thickness 2 x thickness of embedded anchor
Anchor spacing	<ul style="list-style-type: none"> maximum 32 in. on center horizontal x 18 in. on center vertical adjustable two-piece anchors of W1.7 or 22 gauge corrugated sheet metal maximum 2.67 sq.ft. of wall area per anchor all other anchors maximum of 3.5 sq.ft. of wall area per anchor additional anchors around all openings larger than 16 in. in either dimension, spaced 3 ft. on center around opening, and within 12 in. of opening
Air space	minimum 1 in. clear air space
Sheathing	moisture-resistant membrane over non-moisture-resistant sheathing, or moisture-resistant sheathing (with joints taped)
Flashing	designed and detailed to resist water penetration into the building interior, with backing system designed and detailed to resist water penetration
Weep holes	minimum 3/16 in. diameter, maximum spacing 33 in., located immediately above flashing
Differential movement	design and detail veneer to accommodate differential movement
Stack bond	provide joint reinforcement of at least one W1.7 wire spaced a maximum of 18 in. on center vertically

Figure 10-38 Code requirements for masonry veneer. (Based on *Masonry Standards Joint Committee*, Building Code Requirements for Masonry Structures, ACI 530/ASCE 5/TMS 402-02.)

MSJC Prescriptive Seismic Requirements for Anchored Masonry Veneer	
Seismic Risk	Minimum Requirements
Seismic Design Categories A and B	Basic code requirements, no special provisions
Seismic Design Category C	<p>Basic code requirements plus the following special provisions</p> <ul style="list-style-type: none"> Isolate sides and top of anchored veneer from structure so that vertical and lateral seismic forces resisted by the structure are not imparted to the veneer.
Seismic Design Category D	<p>Basic code requirements plus the following special provisions</p> <ul style="list-style-type: none"> Isolate sides and top of anchored veneer from structure so that vertical and lateral seismic forces resisted by the structure are not imparted to the veneer. Support the weight of anchored veneer for each story independent of the other stories. Reduce the maximum wall area supported by each anchor to 75% of that normally required (maximum horizontal and vertical spacings are unchanged). Provide continuous, single-wire joint reinforcement of minimum W1.7 wire at a maximum spacing of 18 in. on center vertically.
Seismic Design Categories E and F	<p>Basic code requirements plus the following special provisions</p> <ul style="list-style-type: none"> Isolate sides and top of anchored veneer from structure so that vertical and lateral seismic forces resisted by the structure are not imparted to the veneer. Support the weight of anchored veneer for each story independent of the other stories. Reduce the maximum wall area supported by each anchor to 75% of that normally required (maximum horizontal and vertical spacings are unchanged). Provide continuous, single-wire joint reinforcement of minimum W1.7 wire at a maximum spacing of 18 in. on center vertically. Provide vertical expansion joints at all returns and corners. Mechanically attach anchors with clips or hooks to joint reinforcement required above.



SEISMIC VENEER ANCHORS

Figure 10-39 Seismic requirements for masonry veneer. (Based on Masonry Standards Joint Committee, Building Code Requirements for Masonry Structures, ACI 530/ASCE 5/TMS 402.)

10.6.3 Brick and CMU Veneer

Brick veneer is most commonly used over wood stud walls in residential buildings and over metal stud backing in steel or concrete structural frames in commercial buildings (see Fig. 10-40). Flexible metal anchors permit horizontal and vertical movement parallel to the plane of the wall but resist tension and compression perpendicular to it. The veneer must transfer lateral wind loads to the backing, and these metal anchors and their mechanical fasteners are the weakest component of the system. Code requirements for spacing of veneer anchors are shown in Fig. 10-41. Additional anchors should be located within 12 in. of openings larger than 16 in. in either dimension at a spacing not to exceed 36 in. on center.

Wire anchors are used to attach veneer to structural steel. For concrete, wire or flat-bar dovetail anchors are recommended. Wire anchors should be at least W2.8 gauge ($3/16$ -in. diameter), with the wire looped and closed (see Chapter 7). Flat-bar dovetail anchors should be 16 gauge, $7/8$ in. wide, and fabricated so that the end embedded in the masonry is turned up $1/4$ in.

For securing brick veneer to residential wood frame construction, corrugated sheet metal anchors are often used. These should be 22-gauge galvanized steel, at least $7/8$ in. wide \times 6 in. long. Corrosion-resistant nails should penetrate the stud a minimum of $1\frac{1}{2}$ in. exclusive of sheathing. The free end of the anchor should be placed in the mortar rather than on top of the brick, and should extend at least 2 in. into the joint (see Fig. 10-42). Corrugated anchors are weak in compression, and provide load transfer only if the horizontal leg is properly aligned in plane with the mortar bed joint and the nail is positioned within $1/2$ in. of the 90° bend. Anchors randomly attached to the backing wall and bent out of plane to align with bed joints serve no useful purpose, and cracking failures are frequent. Corrugated anchors should be used only in low-rise construction, and only if the cavity width does not exceed 1 in.

Brick veneer is anchored to metal stud frames with 9-gauge corrosion-resistant wire hooked through a slotted connector or looped eye for flexibility. Anchors are attached through the sheathing and into the studs with corrosion-resistant, self-tapping screws. Stainless steel screws with a rubber washer will provide a higher level of performance than ordinary galvanized screws. Additional moisture protection is provided by applying a layer of building paper, 15-lb asphalt-saturated felt, or non-woven, non-perforated building wrap over the sheathing. This moisture-resistant membrane is required by code over plywood or OSB sheathing, but will also help protect paper-faced gypsum sheathing. The membrane should be shingle lapped and cover the top edge of the masonry flashing. A protective membrane is not necessary over moisture-resistant sheathing such as fiberglass-faced gypsum panels, but the sheathing joints should be sealed to prevent air or moisture penetration.

The use of brick veneer over metal stud backing is relatively recent in the long history of masonry construction. The system was first introduced as an economical substitute for CMU backup, but it was a false economy based on inadequate size and spacing of studs. Problems with cracking in the brick veneer raised questions about the relative rigidity of masonry veneer versus the flexibility of the stud frame in resisting lateral loads. The BIA now recommends a deflection limit of $L/600$ to provide adequate stiffness in the studs. Lateral bracing or stiffeners in the stud wall may also be required for adequate rigidity to prevent veneer cracking and subsequent moisture intrusion. Sheathing or gypsum board must be attached on both sides to add stiffness, and for typical applications, studs should never be less than a minimum of 16

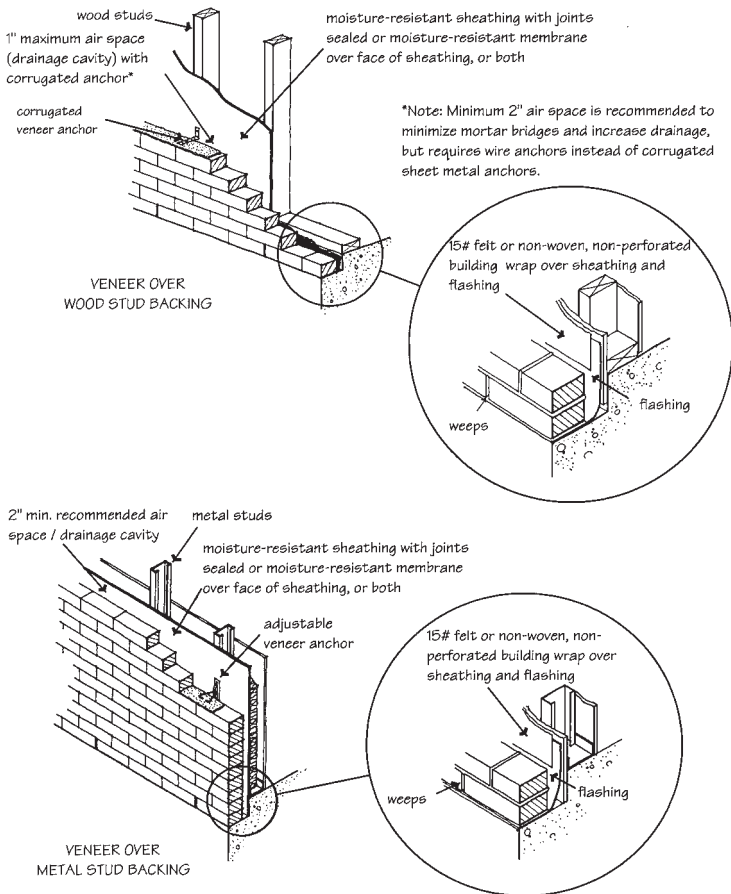


Figure 10-40 Brick veneer walls.

Veneer Anchor Spacing	
Maximum Spacing, Horizontal x Vertical (in. x in.)	Maximum Wall Area Per Anchor (sq.ft.)
32 x 18	adjustable two-piece anchors of W1.7 (9 gauge) wire and 22 gauge corrugated sheet metal anchors, 2.67 all others, 3.5

Recommended Corrosion Protection for Veneer Anchors and Joint Reinforcement	
Application	Corrosion Protection
Interior	mill galvanized ASTM A653, Class G60
Exterior walls and interior walls exposed to mean relative humidity of 75% or more	hot-dip galvanized ASTM A153

Figure 10-41 Requirements for masonry veneer anchors.

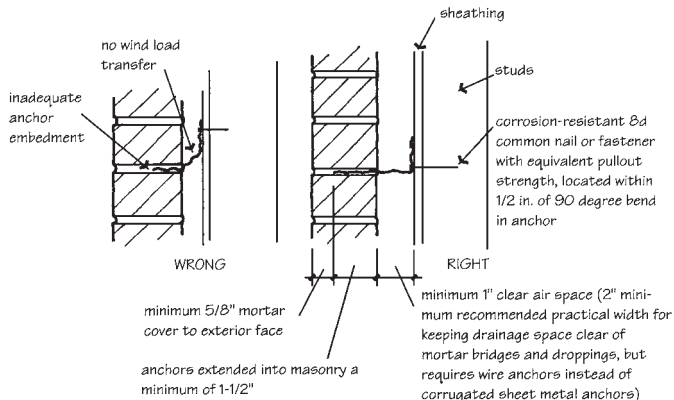


Figure 10-42 Requirements for corrugated anchors.

gauge. Stud spacing should not exceed 16 in., and galvanizing should be by hot-dip process, in accordance with ASTM A525, G60 or G90 coating.

Masonry veneers are designed as drainage wall systems because moisture will always be present, even with good design, good detailing, and good workmanship. Moist environments promote the corrosion of metals, so studs, tracks, and other components must be protected. When galvanized, self-tap-

ping sheet metal screws are driven through galvanized metal studs, both contact surfaces are abraded of their coating, leaving the underlying steel unprotected from moisture corrosion from the outset of its service life. Since fastener head corrosion is often a failure mechanism, galvanized screws are no longer considered adequate corrosion protection. Stainless steel fasteners with a neoprene or EPDM rubber washer will provide a relatively tight seal at the screw penetration and provide a longer service life for the screws themselves. Although this provides a longer service life for the screw itself, questions still remain concerning the pullout strength from the stud if any corrosion is present at the stud penetration. The best defense against such corrosion problems is adequate design for differential movement, proper detailing to limit moisture penetration, and good drainage through a system of flashing and weep holes. (Refer to Chapter 9.)

Grade SW brick is recommended for exterior veneers in most areas of the United States, because the facing is isolated from the rest of the wall and therefore exposed to temperature extremes. Type N mortar is suitable for most veneer construction (refer to Chapter 6 for mortar recommendations). Basic residential and commercial veneer details are shown in *Figs. 10-43 and 10-44*.

Since the overall thickness of a brick veneer wall is approximately 10 in., a foundation wall of at least the same thickness is required for adequate support (*Fig. 10-28*). Many codes permit a nominal 8-in. masonry foundation provided that the top of the wall is corbeled as shown in Chapter 12. The total projection of the corbel cannot exceed 2 in., with individual corbels projecting not more than one-third the height of the unit. Brick veneer should start on a brick ledge below the finish floor line. Moisture entering the wall must be drained to the outside by flashing and weep holes located above grade at the bottom of the wall. Flashing should also be installed at the heads and sills of all openings (*see Figs. 10-45 and 10-46*). The fundamentals of flashing wrap at rough window openings and window sill pan installation are detailed in Chapter 9. The flashing material should be of high quality, because replacement in the event of failure is very costly. Weep holes must be located in the masonry course immediately above all flashing, spaced no more than 24 in. on center horizontally (refer to Chapter 9 for additional flashing and weep-hole details).

In lieu of steel lintels over openings, brick veneer can be reinforced with $\frac{1}{4}$ -in.-diameter deformed steel bars or joint reinforcement placed horizontally in the bed joints above the opening. Where spans and loading permit, this method offers a more efficient use of materials (*see Chapter 11 for design of masonry lintels*).

Four-in. concrete block veneer construction has increased in use with the variety of colors, textures, and patterns of decorative concrete masonry units now available. CMU veneers may be attached in the same manner as clay brick. Anchor spacing is the same as for brick veneers.

Joint reinforcement is used in concrete masonry to control shrinkage cracks. As the stress increases, it is transferred to and redistributed by the steel. The effectiveness of joint reinforcement depends on the type of mortar used and the bond it creates with the wire. Greater bond strength means greater efficiency in crack control. Type N mortar is recommended. Minimum mortar cover to the outside face of the block should be $\frac{3}{8}$ in. for the exterior and $\frac{1}{2}$ in. for the interior wall face. Prefabricated corner and T-type reinforcement is recommended for corners and intersecting walls. Splices should be lapped 6 in. Joint reinforcement and control joint spacing should be as rec-

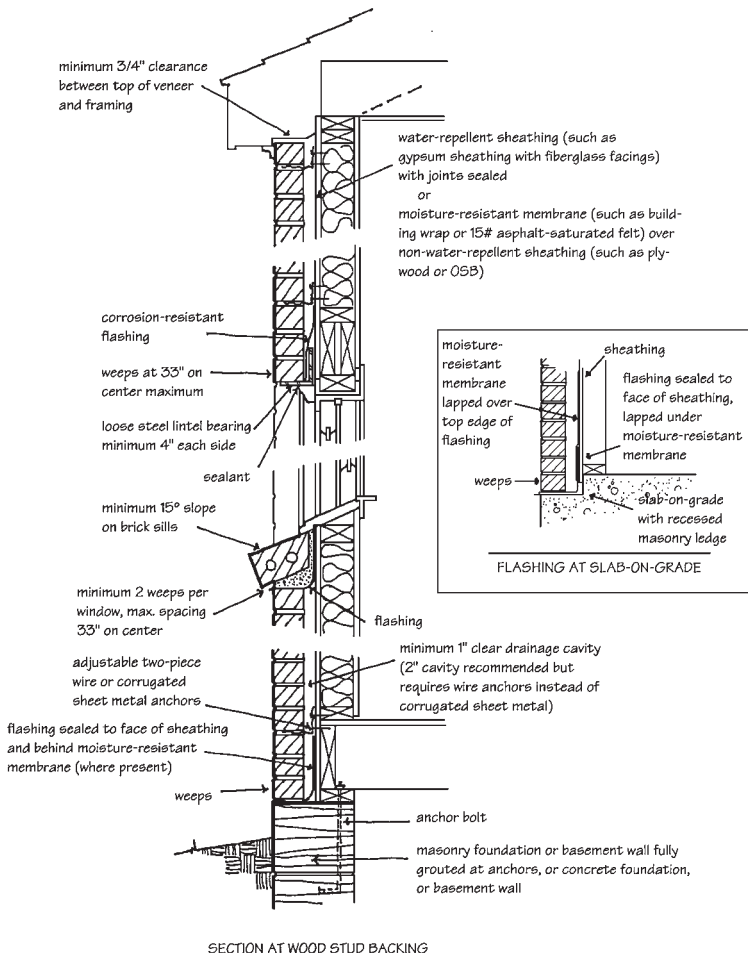


Figure 10-43 Basic residential veneer detailing. (From Beall, *Masonry and Concrete for Residential Construction*, McGraw-Hill Complete Construction Series, McGraw-Hill, New York, 2001.)

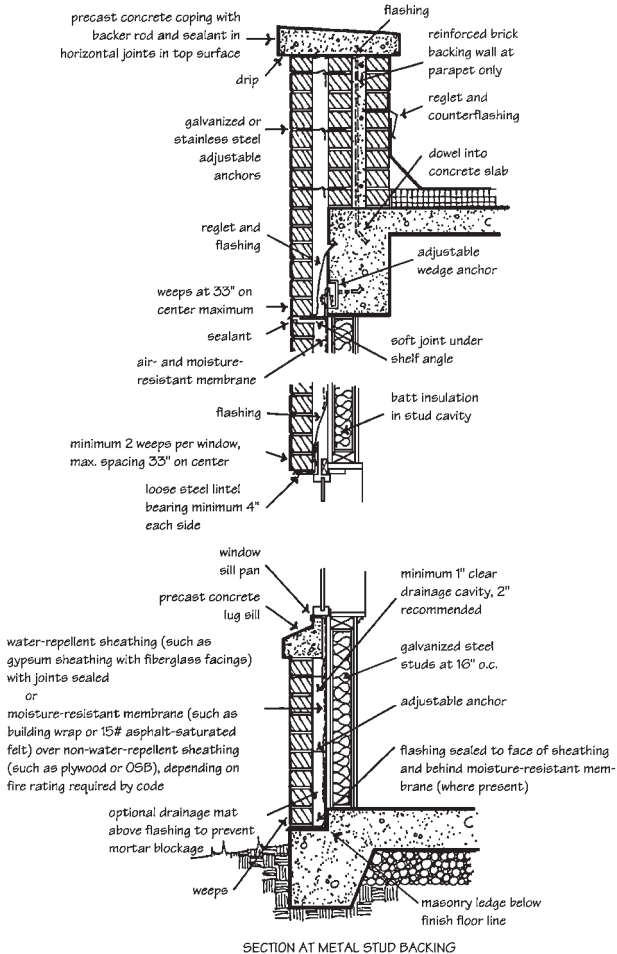


Figure 10-44 Basic commercial veneer detailing. (From *Beall and Jaffe, Concrete and Masonry Databook, McGraw-Hill, New York, 2003.*)

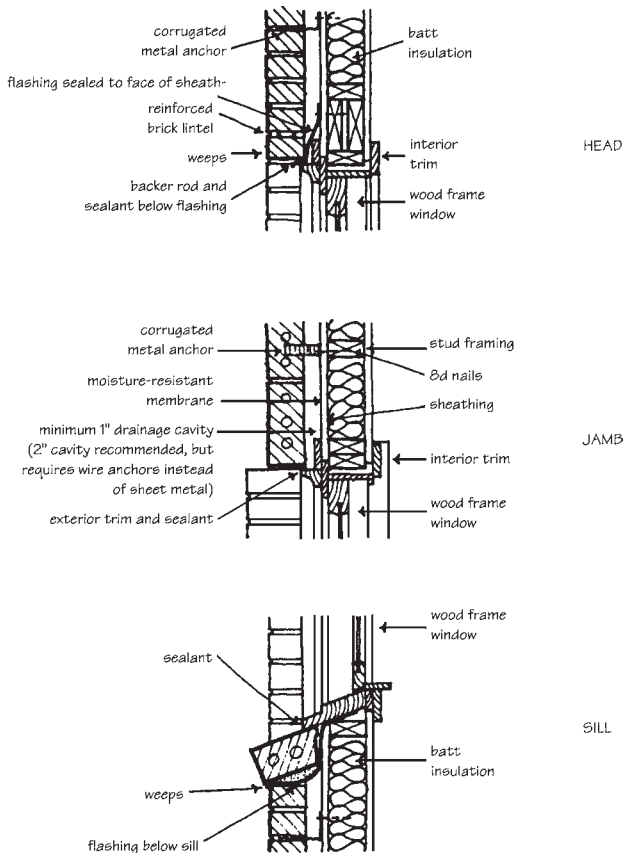
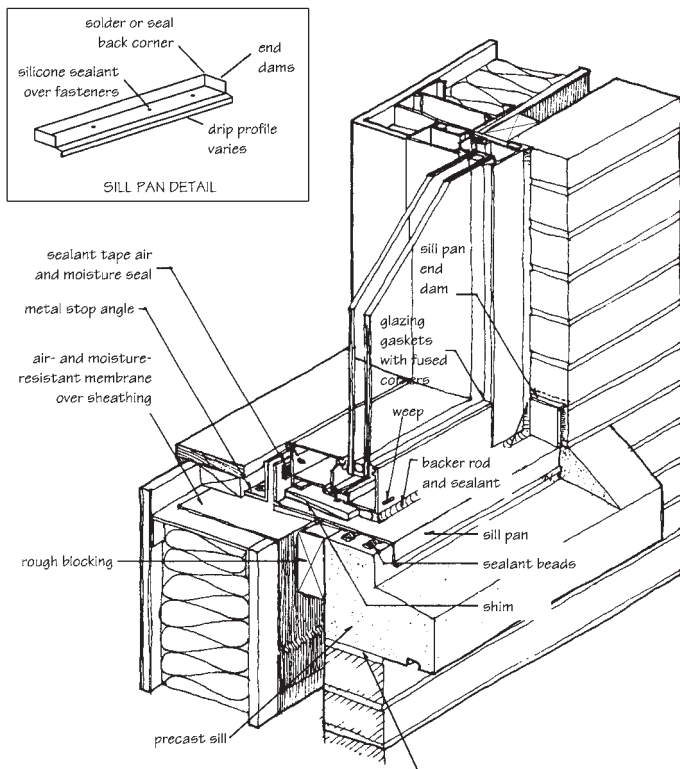


Figure 10-45 Residential wood window head, jamb, and sill details. (From BIA Technical Note 28.)



With metal window sill pan lapped over top of large precast or cast stone sill, flashing under masonry sill is usually not necessary. With brick rowlock or CMU or porous stone sill, water can penetrate through mortar joints or through porous units, so through-wall flashing and weeps should be installed under the masonry sill.

Figure 10-46 Commercial window sill flashing. (Adapted from *Nashed, Time Saver Details for Exterior Wall Design, McGraw-Hill, New York, 1996.*)

Recommended Control Joint Spacing For Above Grade Exposed Concrete Masonry Walls [§]	
Length to Height Ratio	Spacing Between Joints (ft.)
1-1/2	20

[§] Table based on 9 gauge horizontal joint reinforcement spaced 16 in. on center.

[‡] Spacing based on experience over wide geographical area. Adjust spacing where local experience justifies, but not to exceed 20 ft. on center.

Figure 10-47 Control joint spacing for concrete masonry veneers. (From *National Concrete Masonry Association, TEK Bulletin 10-4, NCMA, Herndon, VA.*)

ommended in *Fig. 10-47*. Joint reinforcement may be omitted in CMU veneers if a sufficient number and spacing of control joints are provided to allow for adequate shrinkage crack control.

10.6.4 Stone Veneer

There are two basic types of stone veneer: (1) rubble or cut stone laid in mortar beds, and (2) thin stone slabs mechanically or adhesively attached. Mortar bed construction is generally used in low-rise residential and commercial buildings (see *Fig. 10-48*). The stone may be laid up against a backing of concrete, wood or metal studs, or unit masonry with wire or corrugated sheet metal anchors. The connections must be flexible enough to compensate for the irregularities of mortar bed height. Anchors should be spaced a maximum of 32 in. on center horizontally and 18 in. on center vertically as for other veneer, with the same maximum of 2.67 sq ft per anchor. Metal anchors must have $\frac{5}{8}$ -in. mortar coverage at the outside face of the wall to prevent rusting and corrosion. Type N mortar is recommended.

Stone slab veneers are used as cladding on commercial buildings of low-, medium-, and high-rise construction. The total area of each stone slab depends on the type of stone and its thickness. The IBC requires a 2-in. minimum thickness and limits each slab to a maximum of 20 sq ft. All anchoring systems must be designed to resist a horizontal force equal to twice the weight of the veneer. Some types of stone are drilled around the perimeter for insertion of corrosion-resistant metal dowels. Dowels may be spaced no more than 18 to 24 in. on center, with a minimum of four for each stone unit. Each dowel is secured to the backing with wire or sheet metal anchors (see *Fig. 10-49*). The space between the veneer and the backing surface may be spot-bedded at anchor locations and for alignment. Stone slabs may also be sawed or kerfed at the edges to receive bent metal strap anchors (see *Fig. 10-50*). Carelessly cut kerfs can propagate cracking, and unless filled with a compatible elastomeric sealant, may also retain water. Face joints are usually also filled with an elastomeric sealant rather than with mortar, which might be subject to shrinkage cracking and subsequent moisture penetration (see *Fig. 10-51*). The sealant provides a weather-resistant joint and also permits slight movement of the units to relieve stress.



Figure 10-48 Mortar-bedded stone veneer.

Joint size should be carefully calculated to assure proper sealant performance while accommodating movement and fabrication tolerances (see Chapter 9). Only non-staining sealants compatible with the stone should be used, and stainless steel anchors are recommended.

The design of thin stone cladding systems and anchorages is a very specialized field requiring the services of an engineer or architect experienced in this technology. Specifications should require conformance with ASTM C1242, *Guide for Design, Selection and Installation of Exterior Dimension Stone Anchors and Anchoring Systems*, to assure minimum standards of performance, and designs should be based on recommended factors of safety. Some experts have called safety factors “factors of ignorance” because they are traditionally larger when loads and stresses are uncertain, when the material strength is highly variable, and when the material is not very forgiving. Safety factors for stone have always been very conservative compared to those for ductile materials such as steel. One reason for the conservatism is that stone is a natural material rather than a closely controlled, manufactured product, so physical properties can vary widely, even for the same type of stone from the same quarry (see Chapter 5). Some stones also lose strength after repeated heating-cooling and freeze-thaw cycles, and others gain or lose strength with wet-dry cycles.

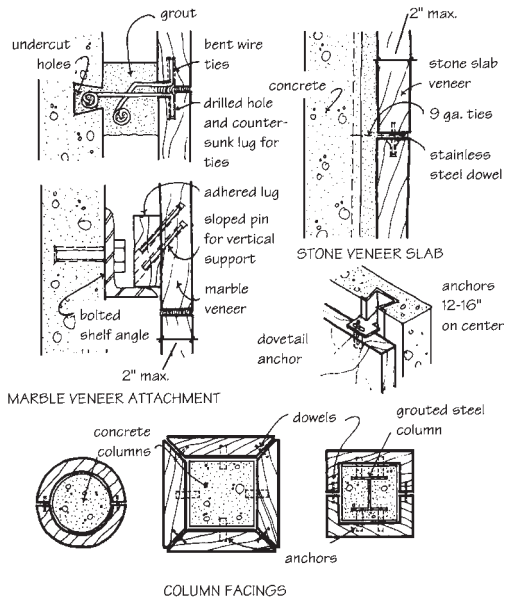


Figure 10-49 Stone slab veneer details. (From *Masonry Institute of America, Masonry Veneer, MIA, Los Angeles, 1974.*)

10.7 PARAPETS

BIA Technical Notes discourage the use of masonry parapets because they are so often the source of leaks. In fact, much of the water that gets into masonry walls enters at either the parapet or around the windows. A roof overhang is the best protection for the tops of masonry walls, but not all architectural styles lend themselves to such design.

Three problems are common with parapets—exposure, movement, and the roofing system interface. Exposure to the elements is more severe in parapets than in the walls beneath them. They are exposed to greater extremes of temperature in both winter and summer. In winter, snow collects on top of the parapet and drifts against the inside wall surface, keeping the masonry saturated throughout months of alternating freeze-thaw cycles. In a wind-driven rain, parapets get wet on both inside and outside surfaces and on all four building elevations regardless of wind direction, and wind pressure is highest at the top of the building (refer to Chapter 9). Some parapet movement is related directly to this exposure. Greater temperature variations cause greater thermal expansion and contraction, and higher moisture contents contribute to greater moisture movement. The winds that drive the

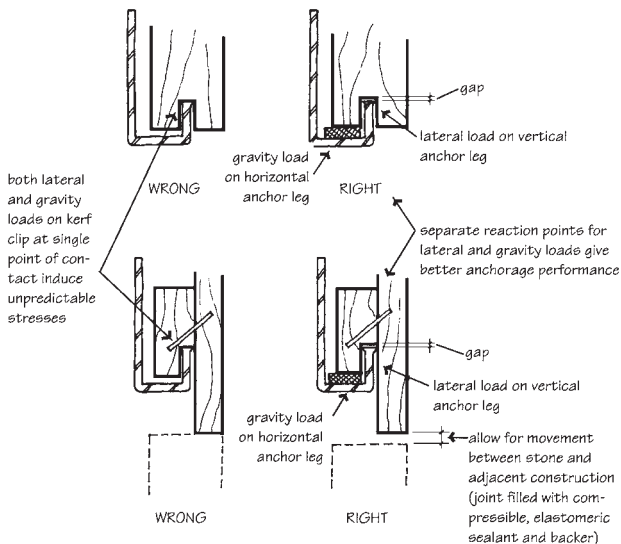


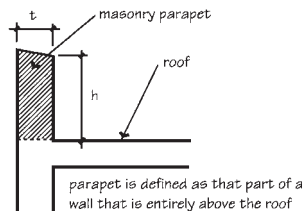
Figure 10-50 Kerf anchorages for stone cladding. (From Lewis, *Modern Stone Cladding*, ASTM Manual 21, ASTM, Philadelphia, 1995.)



Figure 10-51 Elastomeric sealants are used instead of mortar at the joints of stone cladding systems.

rain also induce greater lateral stress at the top of the wall. Code requirements for masonry parapets cover minimum size and structural design (see Fig. 10-52), but do not address weather resistance.

Coping materials for masonry parapets should be selected on the basis of performance as well as compatibility and aesthetics. Metal copings provide the best protection (see Figs. 10-53 and 10-54). They are impervious to moisture and can be installed in lengths requiring a minimum number of joints. Since every joint that occurs on the horizontal surface of a coping is an opportunity for a leak, the fewer joints there are, the greater is the probability of keeping the wall dry. Metal copings should be designed with cover or splice plates to accommodate the differential movement between the masonry and the metal. The size and spacing of the joints will be affected by the movement characteristics of the masonry materials. That is, joints in the metal cap must be able to open to accommodate permanent expansion in brick walls, and close to accommodate permanent shrinkage in concrete masonry walls. The vertical legs of metal copings should extend at least 2 in. below the top course of the masonry, turn out to form a drip, and may be caulked with a high-performance elastomeric sealant. Through-wall flashing should be installed below the metal cap, particularly in high wind areas and over



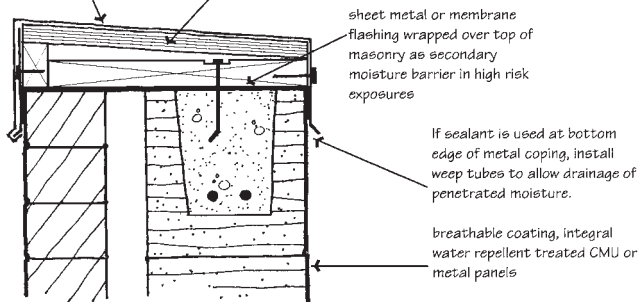
Masonry Parapet Wall Requirements	
Requirement	MSJC*
Minimum thickness (t)	
solid masonry units	8
hollow masonry units	8
Maximum h/t ratio for unreinforced masonry parapets	
solid masonry units	3
hollow masonry units	3
Maximum height of unreinforced masonry parapets	
solid masonry units	3t
hollow masonry units	3t
Maximum wind loads for unreinforced parapets	110 mph basic wind speed
Steel reinforcement required	Seismic Design Categories D, E and F

* Based on requirements of the Masonry Standards Joint Committee *Building Code Requirements for Masonry Structures*, ACI 530/ASCE 5/TMS 402.)

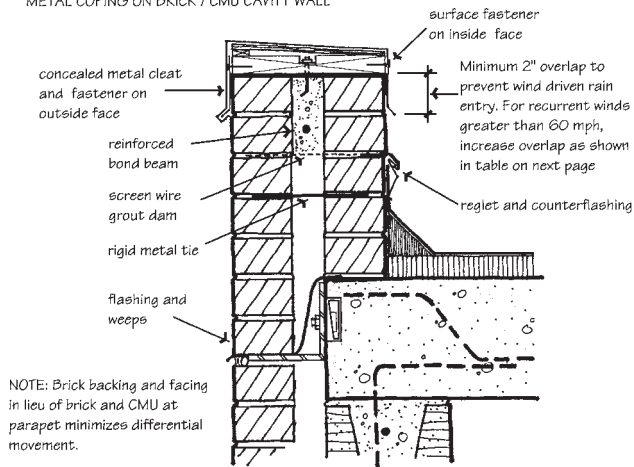
Figure 10-52 Empirical requirements for masonry parapets.

Sloped metal coping with cleat attachment. Do not fasten through top of coping.

2 x 12, blocking and plywood form sloping support for metal cap flashing. Anchor to CMU only to allow differential vertical movement of brick and CMU



METAL COPING ON BRICK / CMU CAVITY WALL



NOTE: Brick backing and facing in lieu of brick and CMU at parapet minimizes differential movement.

METAL COPING ON DOUBLE-WYTHE BRICK PARAPET OVER BRICK / CMU CAVITY WALL

Figure 10-53 Metal coping details for masonry cavity walls.

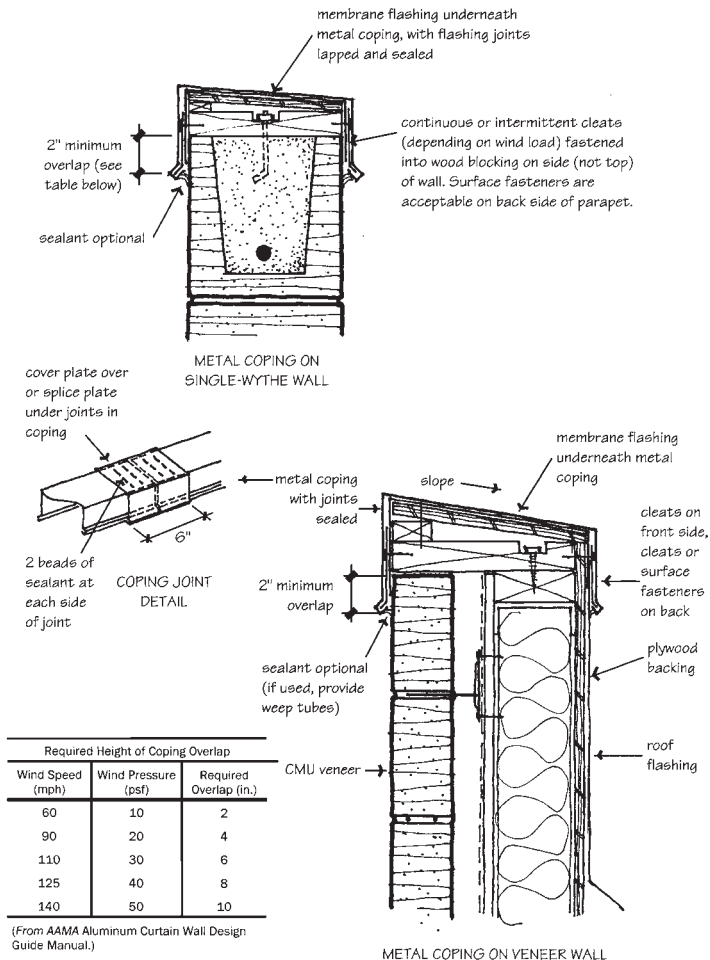


Figure 10-54 Metal coping details for single-wythe and veneer walls.

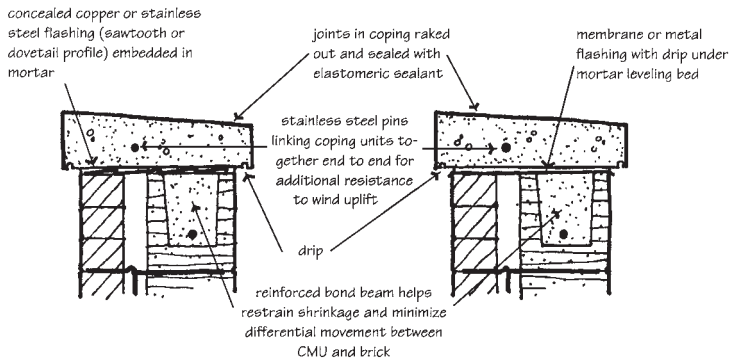
walls with open cores or cavities. If metal flashing is used, the material must be compatible with the metal of the coping itself. All penetrations through this flashing must be sealed with mastic or an elastomeric sealant.

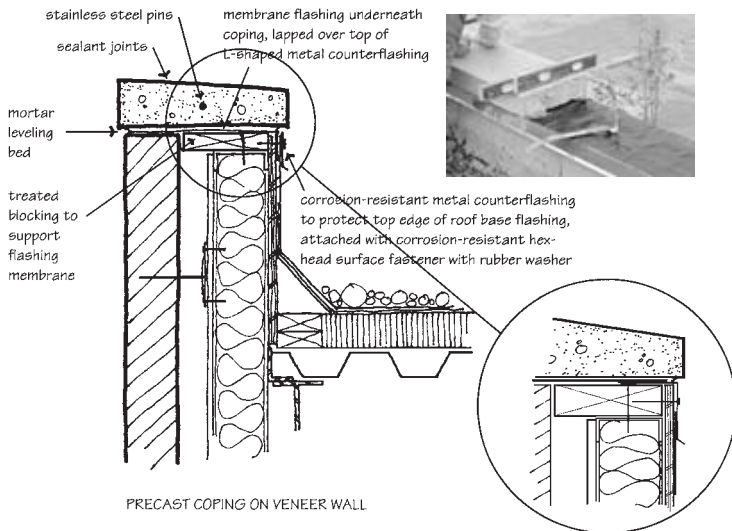
Precast or cast stone copings are shown in *Fig. 10-55*. Because the joints in the coping are vulnerable to moisture penetration, the head joints should be raked out and filled with an elastomeric sealant, and a flashing membrane should *always* be installed below the coping.

In addition to the differential movement between a coping and the wall itself, differential movement between the back and the front of multi-wythe parapet walls must also be considered. Popular details often include a brick veneer, a stone coping, and a utilitarian concrete block backup, but this combination can spell disaster. The brick veneer is increasing in both height and length with permanent moisture expansion at the same time that the concrete masonry is experiencing permanent shrinkage in both directions. Lateral stresses will be highest at the corners, where a brick facing can literally slide off the edge of the building (see *Fig. 10-56*). Unless the mortar is very soft and flexible, a stone coping can be ripped from its mortar bed and twisted out of place, opening joints along both the top and the face of the coping (see *Fig. 10-57*).

To minimize differential movement, the backing and facing wythes of parapets can be constructed of the same material. Tall parapets, or parapets which will be subjected to lateral loads from swing staging or window washing equipment, must be structurally reinforced and anchored to the roof slab (see *Fig. 10-58*). Dowels can be embedded in concrete or masonry supporting structures or welded to structural steel. A fully reinforced parapet is more restrained against thermal and moisture movement, but still requires accommodation of both expansion and contraction. In unreinforced parapets, expansion and contraction can be limited by reinforced bond beams at the top of the wall. This grouted barrier will also protect against direct moisture penetration into hollow masonry cores. For best performance in both brick and concrete masonry parapets, calculations of potential movement should always be based on expected service conditions, and control and expansion joints located accordingly (refer to Chapter 9). The backing and facing of multi-wythe brick parapets should be connected with rigid metal ties, and the wythes of concrete masonry parapets with continuous joint reinforcement. Expansion joints should be located in the last joint in each run of a masonry coping or in the joints adjacent to each corner piece, as well as at calculated intervals along the length of the wall. All mortar joints in masonry copings should be raked out and caulked with elastomeric sealant, because even hairline cracks or separations at the top of the wall act as funnels directing water to the interior.

When masonry copings are specified instead of metal-cap flashing systems, select materials that have expansion and contraction characteristics similar to those of the wall materials. Precast concrete or cast stone copings work well over concrete masonry parapets, and natural or cast stone copings over stone walls. Avoid using brick rowlock copings, because the number of joints on the horizontal surface increases the probability of leaks and the longitudinal joint is almost guaranteed to crack. It is not practical to put a flashing under a brick coping, because the units are not heavy enough to remain stable. Masonry copings should always overhang both sides of the wall and have integral drips. Where a parapet intersects a higher wall, a saddle flashing is used to prevent moisture penetration. This is particularly critical for veneer construction, where the backing wall may include components that are easily damaged by moisture or that support mold growth (see *Fig. 10-59*).



 PRECAST COPING ON CAVITY WALLS


PRECAST COPING ON VENEER WALL

Figure 10-55 Cast stone parapet copings.



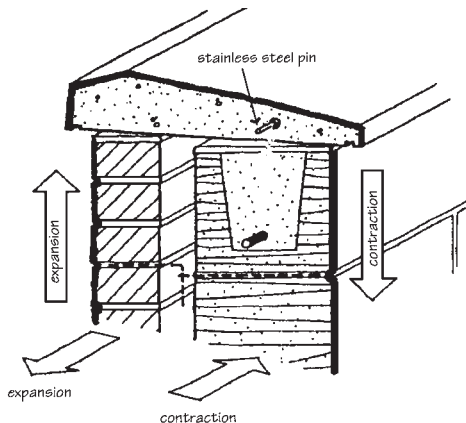
Figure 10-56 Differential expansion between parapet and building wall.

It is not coincidence that roofs frequently leak at the intersection with masonry parapets, and masonry parapets often leak at the intersection with roofing. Where the work of two trades must interface to form a weather-resistant barrier, the blame for failure can often go either way. In the case of masonry parapets and roofing, it is not so much a matter of poor workmanship on the part of either trade, but rather the materials and systems used to form the interface.

Roof flashing must be turned up onto the face of the parapet wall and terminated a minimum of 8 in. above the level of the roof deck. Where it terminates, metal through-wall flashing or counterflashing is used to cap the roof flashing (see Fig. 10-60). Two-piece reglets and counterflashing provide the best interface between work of the two trades. Reglets designed to be placed in the mortar joint are installed by the mason. The roofing contractor removes and replaces the counterflashing while installing the roof. If through-wall flashing is also needed to block moisture flow into the wall cavity below the roof level, a separate metal flashing should lap over the reglet and seal to the backing wall (see Fig. 10-61).

10.8 SHELF ANGLES

Shelf angles are used in masonry veneer to support the dead load of the veneer at each floor. Shelf angles must be installed with a “soft joint” between the bottom of the angle and the top course of masonry below to accommodate differential movement (see Fig. 10-62). This permits differential expansion and contraction of the veneer and structure to occur, as well as deflection and frame shortening, without the angle bearing on the veneer. At each location, flashing and weep holes must be installed to collect moisture and direct it to the outside. The BIA recommends that the flashing be brought beyond the face of the wall and turned down to form a drip. A sealant joint below the flashing is required to prevent water from reentering the joint and penetrating the wall below (see Fig. 10-63). The drip detail makes it difficult to install the sealant, but flashing should never be stopped short of the face of the wall. Rubber flashings cannot be formed into a drip, but they should at least be extended beyond the face of the masonry and



Brick, concrete masonry and precast concrete have different expansion and contraction characteristics which can cause cracking and separation of mortar joints in a masonry coping. The mortar joints between precast coping units should be raked out and filled with a sealant and bond breaker to provide better resistance to the penetration of rain or melting snow.

It is also difficult to mechanically anchor coping units without compromising the integrity of the flashing membrane. In high wind areas, coping units should be as large and heavy as practical to resist wind uplift. For additional wind resistance, adjacent units can also be linked together by inserting stainless steel pins into holes drilled into the head joints.

Figure 10-57 Differential movement in parapets which combine brick, concrete masonry, and precast concrete or cast stone.

later trimmed flush, with a sealant joint installed below. Rubber flashing and bituminous flashings that cannot be exposed to sunlight may also be installed with a separate metal drip. Flashing that is stopped short of the face permits moisture to flow around and underneath, where it can pool in the cores of the brick or block, or enter the cavity of the wall below.

Shelf angle joints can be quite wide, so special detailing is sometimes used to minimize their visual impact. Some manufacturers make special-shaped "lintel brick," with a lip designed to fit down over the end of the angle and reduce the joint width. Using the lipped unit on top of the shelf angle creates an offset that is difficult for the flashing membrane to conform to, so many architects prefer to use the lipped unit in the course below the angle so that flashing installation is easier (see Fig. 10-64A). Lipped units should be

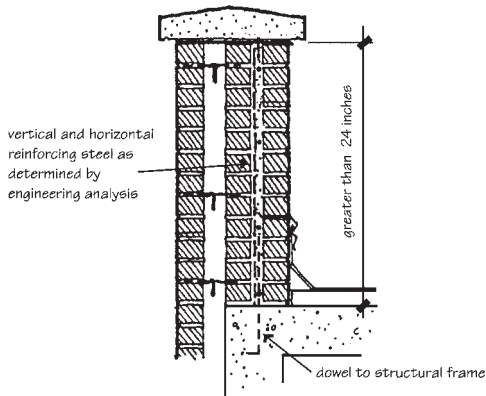
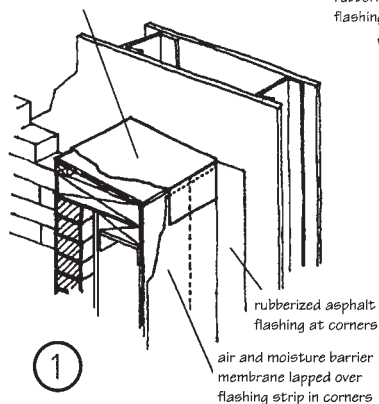


Figure 10-58 Parapets taller than 24 in. are required by code to be reinforced and anchored to the structure.

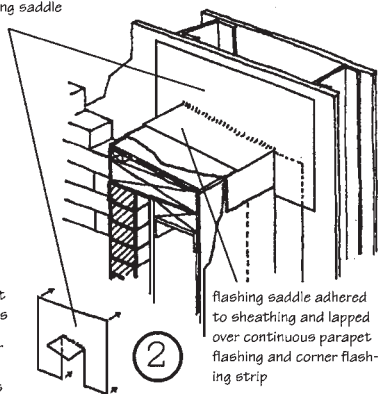
purchased as special-shaped bricks. They should not be field cut because of a tendency with time for the lip to shear off. Horizontal joints can also be articulated using special-shape units such as water table brick (see Fig. 10-64B). This creates a strong shadow line in which the joint and flashing are hidden. The appearance of horizontal movement joints can also be minimized by changing the unit pattern or the unit color for a few courses above or below the shelf angle to create a strong horizontal band. The visual impact of the decorative band distracts the eye from the soft joints, flashing, and weeps above the shelf angle (see Fig. 10-65). Shelf angles must provide continuous support at building corners (see Fig. 10-66) and should be bolted rather than welded in place to permit field adjustments (see Figs. 10-67 and 10-68).

For architects who strongly object to the appearance of horizontal soft joints in a brick masonry facade, the best alternative is to design the veneer as a curtain wall without any shelf angles at all. The veneer rests on the slab and is anchored to the backing wall in the usual way. Most building codes permit this type of construction up to a height of at least 100 ft. The compressive strength of the units is more than adequate to support the dead load of the masonry above. The parapet cap and any terminations at balconies or other protruding or recessed elements must be carefully detailed to allow for vertical expansion of the brick.

rubberized asphalt flashing continuous over parapet and lapped over top of air and moisture barrier membrane



rubberized asphalt flashing saddle



air and moisture barrier membrane lapped over rubberized asphalt saddle flashing and vertical leg of metal coping

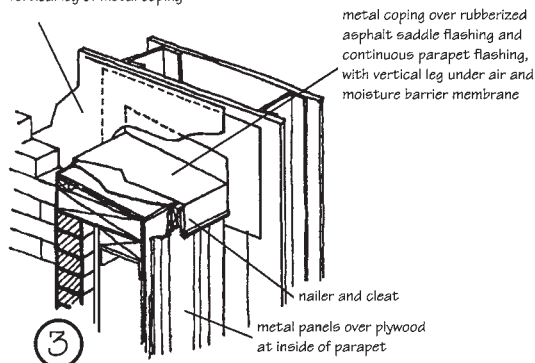


Figure 10-59 Flashing at parapet-to-wall intersection.

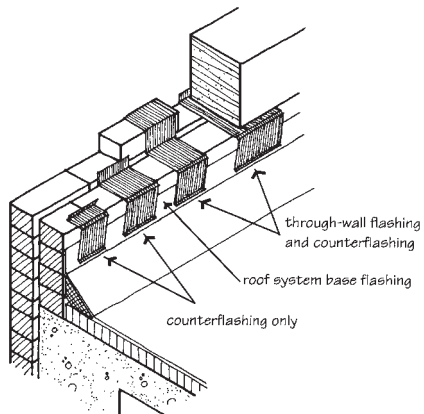
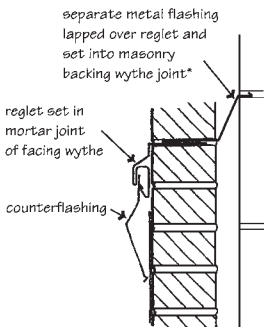
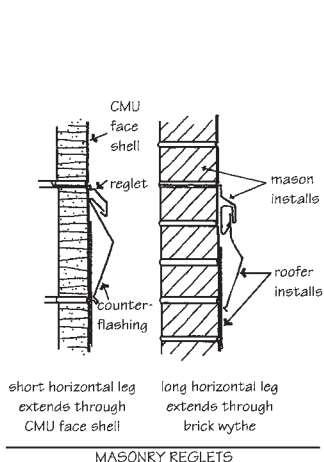
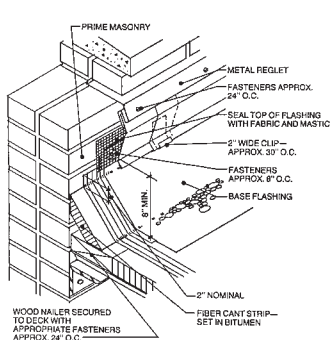


Figure 10-60 Counterflashing and through-wall flashing/counterflashing combinations.

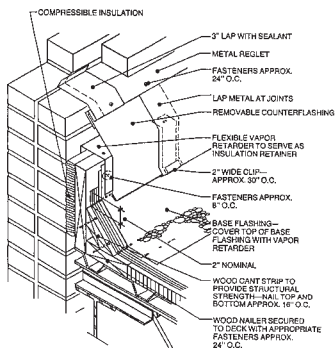


* at veneer walls, lap moisture/air barrier membrane over top edge of flashing, adhere flashing to face of sheathing, use termination bar, or otherwise protect top edge of flashing from water penetration

TWO-PIECE FLASHING AND REGLET WITH REMOVABLE COUNTERFLASHING



no allowance for differential movement
roof deck supported by wall



preferred detail allows for differential movement
roof deck not supported by wall

NRCA RECOMMENDED DETAILS FOR REGLETS AND COUNTERFLASHING AT ROOF

Figure 10-61 Reglets and two-piece flashing/counterflashings at roof-wall intersection.

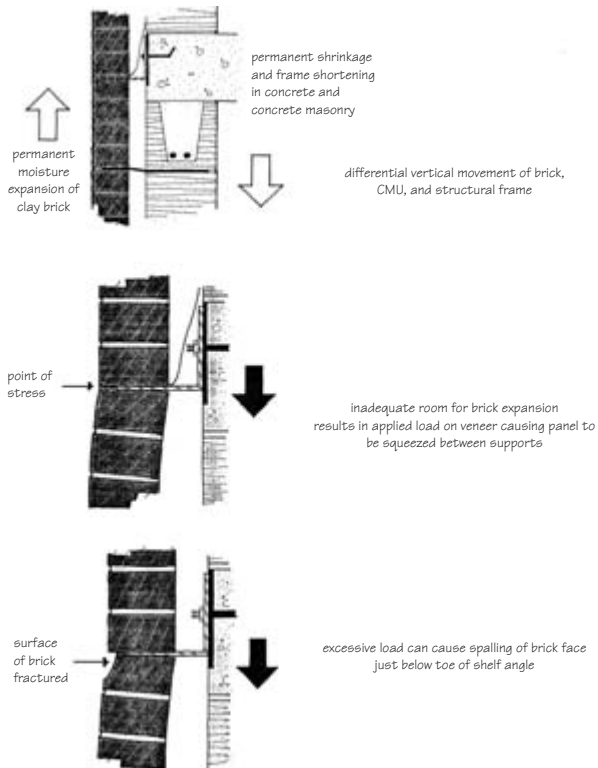


Figure 10-62 Soft joints below shelf angle accommodate differential movement.

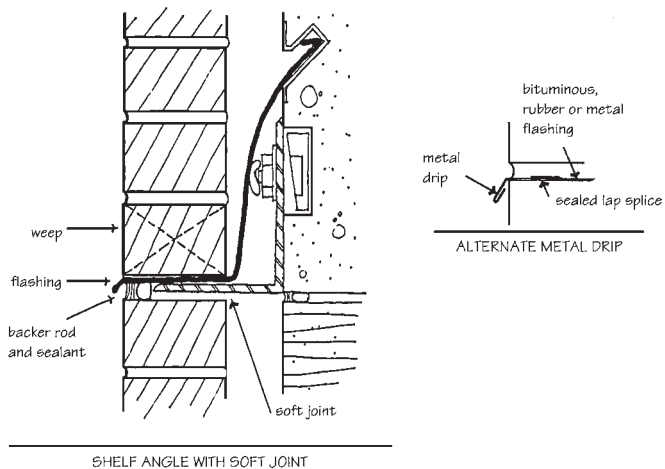


Figure 10-63 Shelf angle flashing.

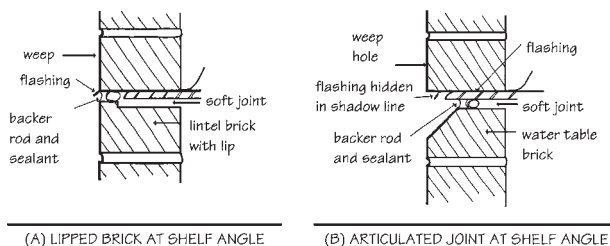
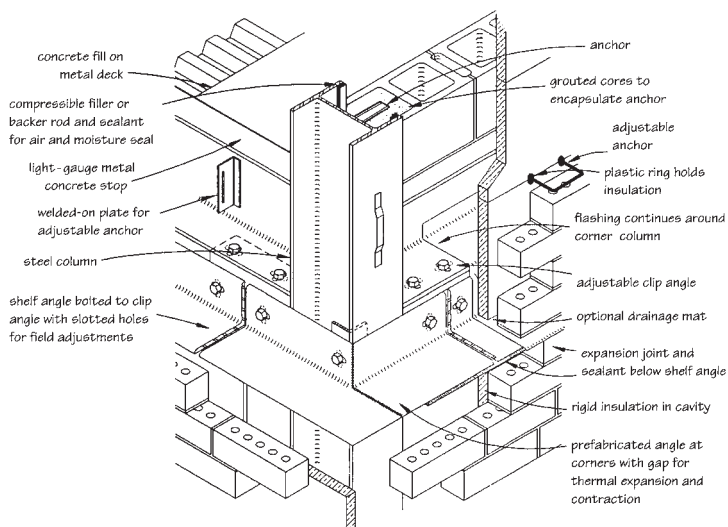


Figure 10-64 Alternate shelf angle details to minimize or articulate the sealant joint.

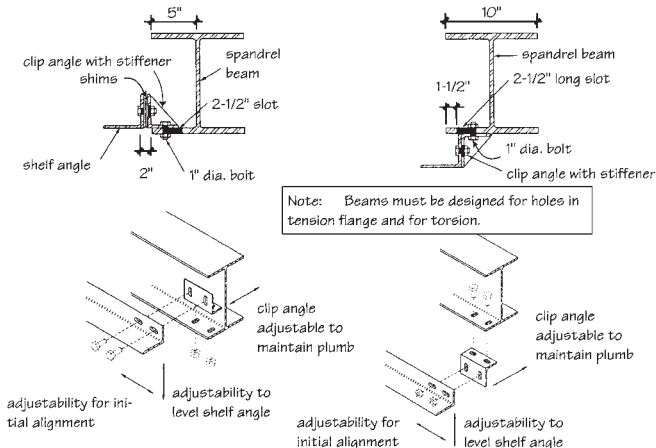


Figure 10-65 Strong horizontal color bands disguise wide soft joints at shelf angles.



SHELF ANGLE AT STEEL COLUMN CORNER

Figure 10-66 Masonry shelf angles must provide continuous support at building corners. (From Laska, *Masonry and Steel Detailing Handbook*, Aberdeen Group, 1993.)



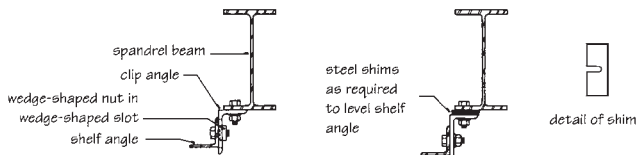
OUTWARD ADJUSTABILITY OF 2"

INWARD ADJUSTABILITY OF 1-1/2"

Allowable Slotted Hole Dimensions

Bolt Diameter (in.)	Standard Hole Diameter (in.)		Short-Slot, Width x Length (in.)		Long Slot, Width x Length (in.)	
	Standard Hole Diameter (in.)	Oversize Hole Diameter (in.)	Short-Slot, Width x Length (in.)	Long Slot, Width x Length (in.)	Long Slot, Width x Length (in.)	Long Slot, Width x Length (in.)
1/2	9/16	5/8	9/16 x 1 1/16	9/16 x 1-1/4		
5/8	11/16	13/16	1 1/16 x 7/8	1 1/16 x 1-9/16		
3/4	13/16	15/16	13/16 x 1	13/16 x 1-7/8		
7/8	15/16	1-1/16	15/16 x 1-1/8	15/16 x 2-3/16		
1	1-1/16	1-1/4	1-1/16 x 1-5/16	1-1/16 x 2-1/2		
≥1-1/8	d + 1/16	d + 5/16	(d + 1/16) x (d + 3/8)	(d + 1/16) x (2.5 d)		

(From Laska, Masonry and Steel Detailing Handbook, 1993.)



ALTERNATE METHOD OF ATTACHING SHELF ANGLES

(From Allen, Fundamentals of Building Construction, 1999)

Figure 10-67 Adjustable shelf angle connections to steel structural frame.

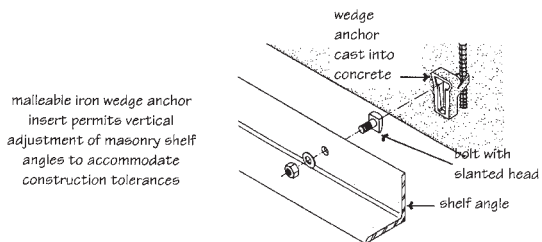


Figure 10-68 Adjustable shelf angle connection to concrete structural frame.

11

LINTELS AND ARCHES

There are two ways to span openings in masonry walls. *Beams and lintels* are horizontal elements which carry loads as flexural members. Masonry *arches* may be flat or curved, but carry loads in compression because of the shape or orientation of the individual units.

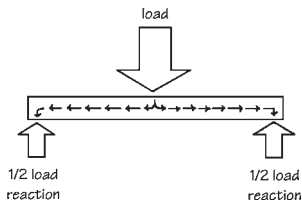
Large wood or stone lintels were used in ancient Egypt and the Middle East to provide small window and door openings in massive loadbearing masonry walls. The strength of individual stones or timbers, however, limited the size of such openings. Early corbeled arches were constructed by progressively projecting the masonry units themselves across the top of an opening until they met at the apex, carrying the load essentially by cantilever action. True compressive arches were developed as early as 1400 B.C. in Babylonia and later perfected by the Romans, along with barrel vaults and domes. In more recent history, brick arches have been used for long spans with heavy loading, as in the railway bridge at Maidenhead, England, built in 1835, which spans 128 ft with a rise of 24.3 ft. A railway bridge constructed in Baltimore in 1895 spans 130 ft with a rise of 26 ft.

This chapter discusses the design of steel, concrete, and masonry lintels and masonry arches. Structural masonry beams for large openings or heavy loads are discussed in Chapter 12.

- 11.1 LINTELS** Lintels of steel, reinforced masonry, stone, concrete, precast concrete, and cast stone and wood are still used today to span small openings in masonry walls. Lintels must resist compressive, bending, and shear stresses (*see Fig. 11-1*). Lintels must be analyzed to determine the actual loads which must be carried and the resulting stresses which will be created in the member. Many of the cracks that appear over door and window openings result from excessive deflection of lintels which have been improperly or inadequately designed.

11.1.1 Load Determination

Regardless of the material used to form or fabricate a lintel, one of the most important aspects of design is the determination of applied loads. When



LOAD TRANSFER IN LINTELS

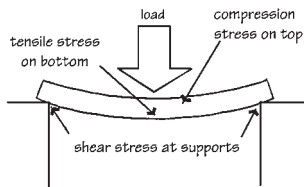
TENSION, COMPRESSION AND
SHEAR IN LINTELS

Figure 11-1 Lintels must resist compressive, bending, and shear stresses. (From Beall and Jaffe, *Concrete and Masonry Databook*, McGraw-Hill, New York, 2003.)

masonry is laid in a running bond pattern, it creates a natural corbeled arch which transfers much of the vertical load to either side of the opening (see *Fig. 11-2*). The area inside a triangle with sides at 45° angles to the lintel represents the masonry which must be supported by the lintel (see *Fig. 11-3*). Outside this area, the weight of the masonry is assumed to be carried to the supporting abutments by natural arching. For this assumption to be true, however, the arching action must be stabilized by a minimum of 8 to 16 inches of masonry above the top of the triangle. There must also be sufficient masonry mass on both sides of the opening to resist the horizontal thrust, and there cannot be a movement joint at either side of the opening. If arching action cannot be assumed to occur because of inadequate height above the load triangle, inadequate thrust resistance, movement joint locations, or because the masonry is not laid in running bond, the lintel must be sized to carry the full weight of the masonry above its entire length (see *Fig. 11-4*). When arching action is assumed, the lintel requires temporary support until the mortar has cured sufficiently to allow the masonry to assume its share of the load. *Figure 11-5* shows an elevation of an opening with a concrete plank floor and concrete beam bearing on the wall, and a graphic illustration of the distribution of these loads. The triangular area (*ABC*) immediately above the opening has sides at 45° angles to the base and represents the area of wall

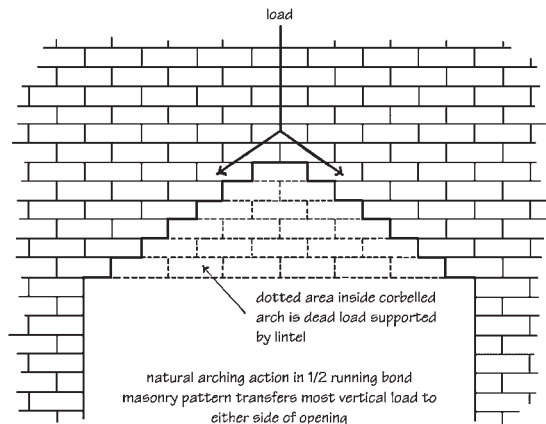


Figure 11-2 Arching action in running bond masonry. (From Beall and Jaffe, *Concrete and Masonry Databook*, McGraw-Hill, New York, 2003.)

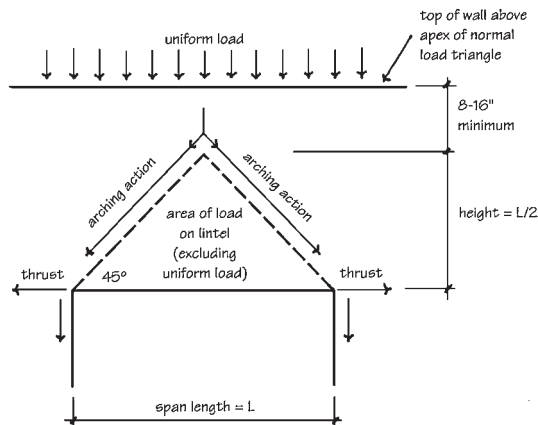


Figure 11-3 Area of lintel load with arching action. (From Beall and Jaffe, *Concrete and Masonry Databook*, McGraw-Hill, New York, 2003.)

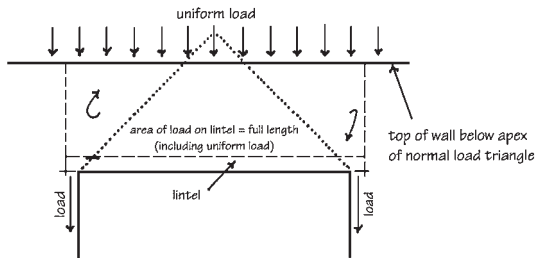


Figure 11-4 Area of lintel load *without* arching action. (From *Beall and Jaffe, Concrete and Masonry Databook, McGraw-Hill, New York, 2003.*)

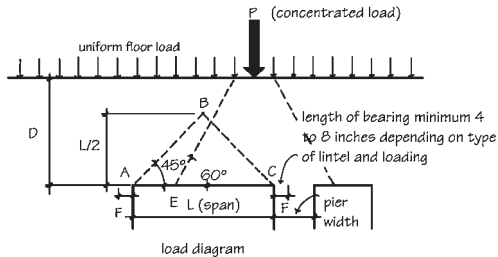
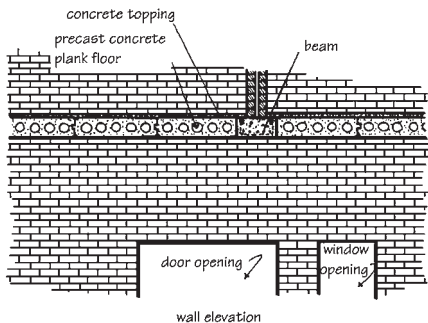


Figure 11-5 Determination of lintel load. (From *BIA Technical Note 31B.*)

weight actually carried by the lintel. "Arching action" of the masonry will carry other loads outside the triangle, provided the height of the wall above the apex is sufficient to resist arching thrusts.

In addition to the dead load of wall contained within the triangular area, the lintel will also carry any uniform floor loads occurring above the opening and below the apex of the triangle. In *Fig. 11-5*, the distance D is greater than $L/2$, so the floor load may be ignored. If arching action does occur as described above, loads outside the triangle may be neglected.

Consideration must also be given to concentrated loads from beams, girders, or trusses which frame into the wall above the opening. These loads are distributed over a length of wall equal to the base of a trapezoid whose summit is at the point of load application and whose sides make an angle of 60° with the horizontal. In *Fig. 11-5*, the portion of concentrated load carried by the lintel is distributed over the length EC and is considered as a uniform load partially distributed. The sum of all loads is used to calculate the size of lintel required to span the opening.

Steel, precast concrete, reinforced concrete masonry units, and reinforced brick lintels are all commonly used to span openings in masonry construction. The table in *Fig. 11-6* lists allowable spans for steel, concrete, and masonry lintels supporting masonry veneer. For single-wythe CMU walls and for loadbearing masonry, engineering analysis should be used to determine lintel or beam sizing and reinforcement.

11.1.2 Steel Lintels

Structural steel shapes are commonly used to span masonry openings. Steel angles are the simplest shapes and are suitable for openings of moderate width where superimposed loads are not excessive (*see Fig. 11-7*). For wider openings such as garage doors, thicker walls, or heavy loads, multiple angles or steel beams with plates or angles may be required (*see Fig. 11-8*). The horizontal leg of a steel angle should support at least two-thirds of the thickness of the masonry.

Using steel lintels to span openings in masonry walls requires careful attention to flashing details, and to provisions for differential movement of the

Allowable Spans for Steel, Concrete and Masonry Lintels Supporting Masonry Veneer

Size of Steel Angle Lintel [‡] , Vertical X Horizontal X Thickness (in.)	Number of 1/2" or Equivalent Reinforcing Bars in Masonry or Concrete Lintels [†]	Less Than One Story of Masonry Above Lintel	Lintel Supporting One Story of Masonry Above Opening	Lintel Supporting Two Stories of Masonry Above Opening
3 x 3 x 1/4	1	6'-0"	4'-6"	3'-0"
4 x 3 x 1/4	1	8'-0"	6'-0"	4'-6"
6 x 3-1/2 x 5/16	2	14'-0"	8'-0"	6'-0"
5 x 3-1/2 x 5/16	2	10'-0"	9'-6"	7'-0"
two 6 x 3-1/2 x 5/16	4	20'-0"	12'-0"	9'-6"

[‡] Steel lintels indicated are adequate typical examples. Other steel lintels meeting structural design requirements may be used.

[†] Depth of reinforced lintels shall not be less than 8 inches, and all cells or cores of hollow masonry lintels shall be grouted solid. Reinforcing bars shall extend not less than 8 inches into the support.

Figure 11-6 Allowable spans for lintels in masonry veneer. (From International Residential Code for One and Two Family Dwellings, 2003.)

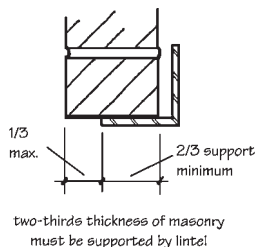


Figure 11-7 Steel lintel.

steel and masonry. Code requirements for fireproofing of steel members should also be thoroughly investigated. If fireproofing is required, it may be simpler to design the lintel as a reinforced masonry section. Steel lintels should be galvanized to prevent corrosion when they will be exposed to the weather.

11.1.3 Concrete and Concrete Masonry Lintels

Openings in concrete masonry walls are more commonly spanned with U-shaped lintel blocks grouted and reinforced with deformed steel bars. Reinforced concrete masonry lintels not only cost less than structural steel lintels, they eliminate the danger of steel corrosion and subsequent masonry cracking, as well as the painting and maintenance of exposed steel.

In some instances, cast-in-place or precast concrete sections can also be used. *Cast-in-place lintels* are subject to drying shrinkage and have surface textures that are not always compatible with the adjoining masonry. *Precast concrete lintels* and *cast stone lintels* are better in some respects because they are delivered to the job site ready for use, do not require temporary shoring, and can carry superimposed loads as soon as they are in place. These sections can be produced with surface textures closely matching that of the masonry, and can be scored vertically to simulate mortar joints. Precast lintels may be one-piece, or may be split into two thinner sections. Split lintels are relatively lightweight and easily handled. Split lintels, however, are not recommended to support combined wall and floor loads, because of the difficulty involved in designing the heavily loaded inner section to match the deflection of the outer section, which may carry only wall loads. Differential deflection could cause critical stress concentrations in the wall. Mortar for bedding precast lintels should be the same quality as that used in laying the wall, and at least equal to ASTM C270, Type N.

Reinforced concrete masonry lintels are constructed with special-shaped lintel units, bond beam units, or standard units with depressed, cut-out, or grooved webs to accommodate the steel bars (see Fig. 11-9). Individual units are laid end to end to form a channel in which continuous reinforcement and grout are placed. Among the major advantages of CMU lintels over steel are low maintenance and the elimination of differential movement between dissimilar materials. Concrete masonry lintels are often designed as part of a continuous bond beam course, which helps to further distribute shrinkage and temperature stresses in the masonry above openings. This type of installation is more satisfactory in areas subject to seismic activity.

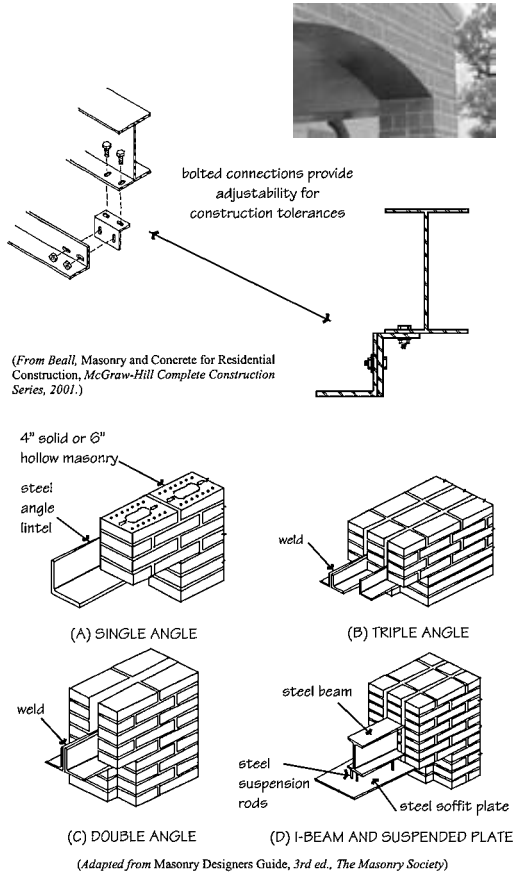


Figure 11-8 Simple, compound, and curved steel lintels.

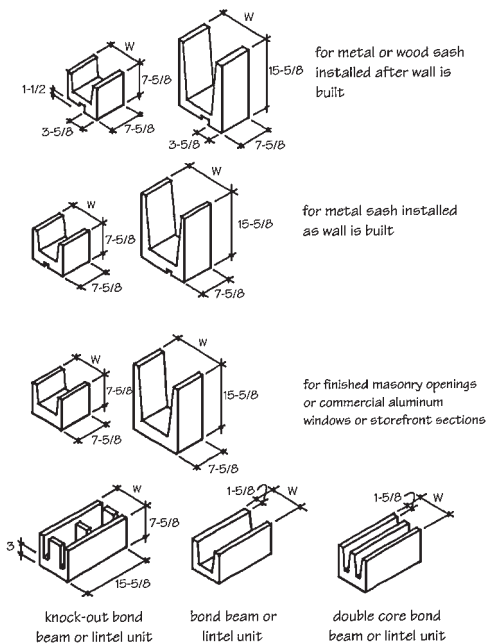


Figure 11-9 Concrete masonry lintel units.

Units used for lintel construction should comply with the requirements of ASTM C90, *Standard Specification for Loadbearing Concrete Masonry Units*, and should have a minimum compressive strength adequate to provide the masonry compressive strength (f'_m) used in the design. Mortar should be equal to that used in constructing the wall and should meet the minimum requirements of ASTM C270, Type N. Grout for embedment of reinforcing steel should comply with ASTM C476, and maximum aggregate size is dependent on the size of the grout space (see Chapter 6). The first course of masonry above the lintel should be laid with full mortar bedding so that the cross webs as well as the face shells of the units bear on the lintel and reduce the shear stress between the grout-filled core and the face shells.

A minimum end bearing of 8 in. is recommended for reinforced CMU lintels with relatively modest spans. For longer spans or heavy loads, bearing stresses should be calculated to ensure that the allowable compressive stress of the masonry is not exceeded. High stress concentrations may require the

use of solid units or solidly grouted hollow units for one or more courses under the lintel bearing, so that loads are distributed over a larger area.

The National Concrete Masonry Association (NCMA) design table in *Fig. 11-10* is based on typical equivalent uniform loads of 200 to 300 lb/lin ft for wall loads, and 700 to 1000 lb/lin ft for combined floor and roof loads. The table can be used to determine required lintel size and reinforcing for various spans subject to this type of loading.

11.1.4 Reinforced Brick Lintels

Standard brick masonry units are also adaptable to reinforced lintel design even though they do not have continuous channels for horizontal steel. Reinforcing may be located in bed joints or in a widened collar joint created by using half-units (*see Fig. 11-11*). Manufacturers of 8-in. hollow brick also produce lintel units similar to those of concrete masonry.

Figure 11-12B shows a reinforced brick lintel capable of carrying the same loads as the three steel gins in *Fig. 11-12A*. The reinforced brick lin-

Required Reinforcement for Simply Supported CMU Lintels		Clear Span							
Type of Loading	Nominal Size of Lintel Section (in.)	3'-4"	4'-0"	4'-8"	5'-4"	6'-0"	6'-8"	7'-4"	8'-0"
Wall loads (200-300 lb/in.ft)	6 x 8	1 #3	1 #4	1 #4	2 #4	2 #5	—	—	—
	6 x 16	—	—	—	—	1 #4	1 #4	1 #4	1 #4
Floor and roof loads (700-1000 lb/in.ft)	6 x 16	1 #4	1 #4	2 #3	1 #5	2 #4	2 #4	2 #5	2 #5
	8 x 8	1 #3	2 #3	2 #3	2 #4	2 #4	2 #5	2 #6	—
Wall loads (200-300 lb/in.ft)	8 x 16	—	—	—	—	—	—	2 #5	2 #5
	8 x 8	2 #4	—	—	—	—	—	—	—
Floor and roof loads (700-1000 lb/in.ft)	8 x 16	2 #3	2 #3	2 #3	2 #4	2 #4	2 #4	2 #5	2 #5

Figure 11-10 Steel reinforcement for CMU lintels. (From *National Concrete Masonry Association, TEK Bulletin 25, NCMA, Herndon, VA.*)

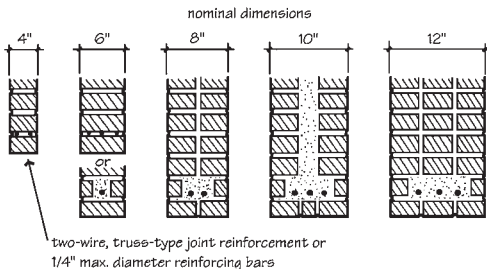


Figure 11-11 Reinforced brick lintels.

tel is more economical because less steel is required, so it is a more efficient use of structural materials. The combined action of the masonry and the steel reinforcing bars is more efficient than support provided by steel alone.

11.1.5 Prefabrication

Reinforced brick and concrete masonry lintels are normally built in place by using temporary shoring to support the wall weight until the section has cured sufficiently to carry superimposed loads. Soffit brick may be standard units or special shapes, and is laid with mortar in the head and collar joints only. Reinforced brick and CMU lintels may also be prefabricated, however. This eliminates the need for shoring and allows work to proceed more rapidly.

11.2 ARCHES

Arches can be constructed in various forms, such as *segmental*, *elliptical*, *Tudor*, *Gothic*, *semicircular*, and *parabolic* to *flat* or *jack* arches (see Fig. 11-13). The primary advantage of an arch is that under uniform loading conditions, the induced stress is principally compression rather than tension (see Fig. 11-14). For this reason, an arch will frequently provide the most efficient structural span. Since masonry's resistance to compression is greater than to other stresses, it is an ideal material for the construction of arches.

Arches are divided structurally into two categories. *Minor arches* are those whose spans do not exceed 6 ft with a maximum rise/span ratio of 0.15, with equivalent uniform loads of the order of 1000 lb/ft. These are most often used in building walls over door and window openings. *Major arches* are those whose spans or loadings exceed the maximum for minor arches. With larger spans and uniformly distributed loads, the parabolic arch is often the most structurally efficient form.

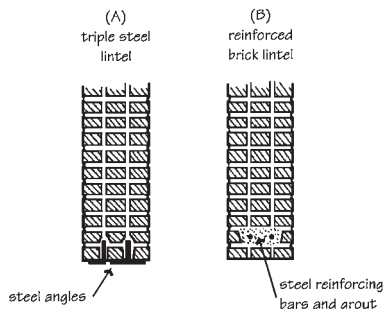


Figure 11-12 Steel angle lintel (A) is less efficient because it requires more steel than a reinforced brick lintel (B) with same load-carrying capacity. (From BIA Technical Note 17H.)

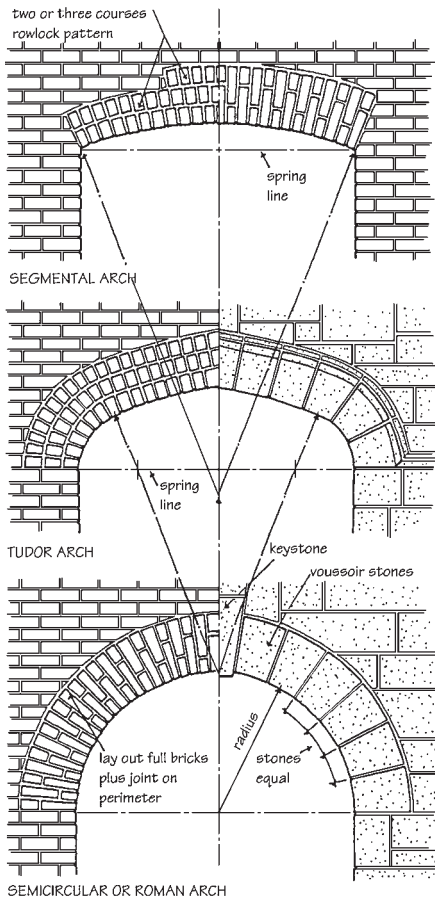


Figure 11-13 Masonry arch forms. (From BIA Technical Note 31.)

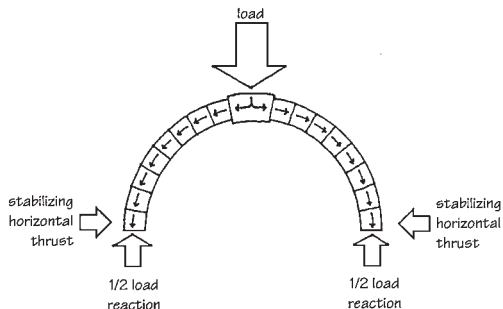


Figure 11-14 Load distribution in masonry arches. (From Beall and Jaffe, *Concrete and Masonry Databook*, McGraw-Hill, New York, 2003.)

11.2.1 Minor Arch Design

In a fixed masonry arch, three conditions must be maintained to ensure the integrity of the arch action: (1) the length of span must remain constant; (2) the elevation of the ends must remain unchanged; and (3) the inclination of the skewback must be fixed. If any of these conditions is altered by sliding, settlement, or rotation of the abutments, critical stresses can develop and may result in structural failure. Adequate foundations and high-quality mortar and workmanship are essential to proper arch construction. The compressive and bond strength of the mortar must be high, and only Types M, S, and N are recommended. It is also particularly important that mortar joints be completely filled to assure maximum bond and even distribution of stresses.

Arches are designed by assuming a shape and cross section based on architectural considerations or empirical methods, and then analyzing the shape to determine its adequacy to carry the superimposed loads. The following discussion of arch design is taken from the Brick Industry Association's *Technical Notes*, Series 31. Minor arch loading may consist of live and dead loads from floors, roofs, walls, and other structural members. These may be applied as concentrated loads or as uniform loads fully or partially distributed. The dead load on an arch is the weight of the wall area contained within a triangle immediately above the opening. The sides of the triangle are at 45° angles to the base, and its height is therefore one-half of the span. Such triangular loading is equivalent to a uniformly distributed load of 1.33 times the triangular load. Superimposed uniform loads above this triangle are carried beyond the span of the opening by arching action of the masonry wall itself when running bond patterns are used. Uniform live and dead loads below the apex of the triangle are applied directly on the arch for design purposes. Minor concentrated loads bearing directly or nearly directly on the arch may safely be assumed as equivalent to a uniformly distributed load twice the magnitude of the concentrated load. Heavy concentrated loads should not be allowed to bear directly on minor arches (especially jack arches).

There are two basic theories for verification of the stability of an assumed arch section. The *elastic theory* considers the arch as a curved beam subject to moment and shear, whose stability depends on internal stresses. For arches subject to non-symmetrical loading that can cause tensile stress development, the elastic theory provides the most accurate method of analysis. There are many methods of elastic analysis for arch design, but in most instances their application is complicated and time consuming. Such detailed engineering discussions are beyond the scope of this book, and the reader is referred to Valerian Leontovich's *Frames and Arches* (McGraw-Hill, New York, 1959) for further information.

A second theory of analysis is the *line-of-thrust method*, which considers the stability of the arch ring to be dependent on friction and the reactions between the several arch sections or voussoirs. In general, the line-of-thrust method is most applicable to symmetrical arches loaded uniformly over the entire span or subject to symmetrically placed concentrated loads. For such arches, the line of resistance (which is the line connecting the points of application of the resultant forces transmitted to each voussoir) is required to fall within the middle third of the arch section, so that neither the intrados nor extrados of the arch will be in tension (see Fig. 11-15 for arch terminology).

11.2.2 Graphic Analysis

The simplest and most widely used line-of-thrust method is based on the hypothesis of "least crown thrust," which assumes that the true line of resistance of an arch is that for which the thrust at the crown is the least possible consistent with equilibrium. This principle can be applied by static methods if the external forces acting on the arch are known and the point of application and direction of crown thrust are assumed. Normally, the direction of the crown thrust is assumed as horizontal and its point of application as the upper extremity of the middle one-third of the section (i.e., two-thirds the arch depth from the intrados). This assumption has been proven reasonable for symmetrical arches loaded symmetrically, but is not applicable to non-symmetrical or partially distributed uniform loads.

With these assumptions, the forces acting on each section of an arch may be determined by analytical or graphic methods. The first step in the procedure is to determine the joint of rupture. This is the joint for which the tendency of the arch to open at the extrados is the greatest and which therefore requires the greatest crown thrust applied to prevent the joint from opening. At this joint, the line of resistance of the arch will fall on the lower extremity of the middle third of the section. For minor segmental arches, the joint of rupture is ordinarily assumed to be the skewback of the arch. (For major arches with higher rise/span ratios, this will not be true.) Based on the joint of rupture at the skewback and the hypothesis of least crown thrust, the magnitude and direction of the reaction at the skewback may be determined graphically (see Fig. 11-16).

In this analysis, only one-half of the arch is considered, since it is symmetrical and uniformly loaded over the entire span. Figure 11-16A shows the external forces acting on the arch section. For equilibrium, the lines of action of these three forces ($W/2$, H , and R) must intersect at one point as shown in Fig. 11-16B. Since the crown thrust (H) is assumed to act horizontally, this determines the direction of the resisting force (R). The magnitude of the resistance may be determined by constructing a force diagram as indicated in Fig. 11-16D. The arch is divided into voussoirs and the uniform load trans-

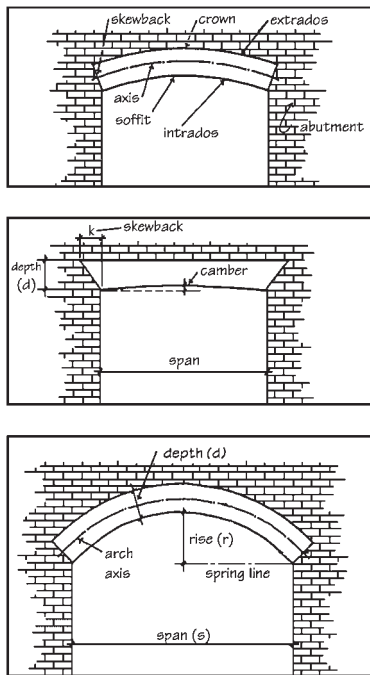


Figure 11-15 Arch terminology (see the Glossary in Appendix A). (From BIA Technical Note 31A.)

formed into equivalent concentrated loads acting on each section (see Fig. 11-16C). Starting at any convenient point (in this example, between the reaction and the first load segment past the skewback), numbers are placed between each pair of forces, so that each force can subsequently be identified by a number (i.e., 1-2, 5-6, 7-1, and so on). The side of the force diagram which represents $W/2$ (Fig. 11-16D) is divided into the same number of equivalent loads, and the same numbers previously used for identification are placed as shown in Fig. 11-16E to identify the forces in the new force diagram. Thus, the line 7-1 is the skewback reaction, 6-7 the horizontal thrust, and so on. From the intersection of H and R (7-1 and 6-7) a line is drawn to each intermediate point on the leg representing $W/2$.

The equilibrium polygon may now be drawn. First extend the line of reaction until it intersects the line of action of 1-2 (see Fig. 11-16F). Through

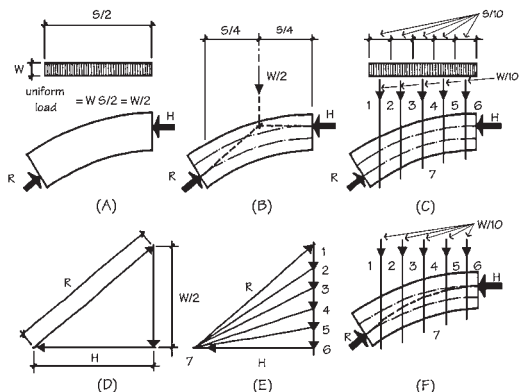


Figure 11-16 Graphic arch analysis. (From BIA Technical Note 31.)

this point, draw a line parallel to the line 7-2 until it intersects the line of action of 2-3. Through this point, draw a line parallel to the line 7-3, and so on, and complete the polygon in this manner. If the polygon lies completely within the middle third of the arch section, the arch is stable. For a uniformly distributed load, the equilibrium polygon, which coincides with the line of resistance, will normally fall within this section, but for other loading conditions it may not.

The eccentricity of the voussoir reactions will produce stresses which differ from the axial stress H/A , where A is the cross-sectional area of the arch ($A = bd$). These stresses are determined by the formula

$$f_m = \frac{H}{bd} \pm \frac{6He}{bd} \quad (11.1)$$

where f_m = maximum compressive stress in the arch, psi

H = horizontal thrust, lb

b = thickness of the arch, in.

d = depth of the arch, in.

e = perpendicular distance between the arch axis and the line of action of the horizontal thrust, in.

Maximum allowable compressive stresses in an arch are determined on the basis of the compressive strength of the units and mortar, and are governed by the same code requirements as other masonry construction (see Chapter 12).

A number of mathematical formulas have been developed for the design of minor arches. Among the structural considerations are three methods of failure of unreinforced masonry arches: (1) by rotation of one section of the arch about the edge of a joint; (2) by the sliding of one section of the arch on another or on the skewback; and (3) by crushing the masonry.

11.2.3 Rotation

The assumption that the equilibrium polygon lies entirely within the middle third of the arch section precludes the rotation of one section of the arch about the edge of a joint or the development of tensile stresses in either the intrados or extrados. For conditions other than evenly distributed uniform loads, where the polygon may fall outside the middle third, however, this method of failure should be considered.

11.2.4 Sliding

The coefficient of friction between the units of a masonry arch is at least 0.60 without considering the additional resistance to sliding resulting from the bond between the mortar and the masonry units. This corresponds to an angle of friction of approximately 31° . If the angle between the line of resistance and a line perpendicular to the joint between sections is less than the angle of friction, the arch is stable against sliding. This angle may be determined graphically as shown above. For minor segmental arches, the angle between the line of resistance and a line perpendicular to the joint is greatest at the skewback. This is also true for jack arches if the joints are radial about a center at the intersection of the planes of the skewbacks. However, if the joints are not radial about this center, each joint should be investigated separately for resistance to sliding. This can be most easily accomplished by constructing an equilibrium polygon.

11.2.5 Crushing

A segmental arch is one whose curve is circular but is less than a semicircle. The minimum recommended rise for a segmental arch is 1 in. per foot of span. The horizontal thrust developed depends on the span, depth, and rise of the arch.

The graph in *Fig. 11-17* identifies thrust coefficients (H/W) for segmental arches subject to uniform loads over the entire span. Once the thrust coefficient is determined for a particular arch, the horizontal thrust (H) may be determined as the product of the thrust coefficient and the total load (W). To determine the proper thrust coefficient, first determine the characteristics S/r and S/d of the arch, where S is the clear span in feet, r is the rise of the soffit in feet, and d is the depth of the arch in feet. If the applied load is triangular or concentrated, the same method may be used, but the coefficient H/W is increased by one-third for triangular loading and doubled for concentrated loads.

Once the horizontal thrust has been determined, the *maximum compressive stress* in the masonry is determined by the formula

$$f_m = \frac{2H}{bd} \quad (11.2)$$

This value is twice the axial compressive stress on the arch due to the load H , because the horizontal thrust is located at the third point of the arch depth.

The common rule for *jack arches* is to provide a skewback (K measured horizontally; see *Fig. 11-15*) of $\frac{1}{2}$ in. per foot of span for each 4 in. of arch depth. Jack arches are commonly constructed in depths of 8 and 12 in. with a camber of $\frac{1}{8}$ in. per foot of span. To determine the *horizontal thrust* at the spring line for jack arches, the following formulas may be used:

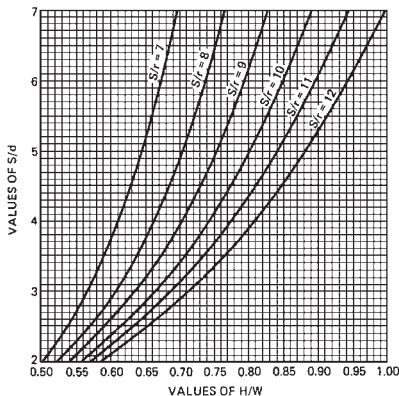


Figure 11-17 Thrust coefficients for segmental arches.
(From BIA Technical Note 31A.)

For uniform loading over full span:

$$H = \frac{3WS}{8d} \quad (11.3)$$

For triangular loading over full span:

$$H = \frac{WS}{2d} \quad (11.4)$$

Maximum compressive stress may be determined by the formulas

$$f_m = \frac{2H}{6d} \quad (11.5)$$

For uniform loading over full span:

$$f_m = \frac{3WS}{4bd} \quad (11.6)$$

For triangular loading:

$$f_m = \frac{WS}{6d} \quad (11.7)$$

11.2.6 Thrust Resistance

The horizontal thrust resistance developed by an arch is provided by the adjacent mass of the masonry wall. Where the area of the adjacent wall is substantial, thrust is not generally a problem. However, at corners and openings where the resisting mass is limited, it may be necessary to check the

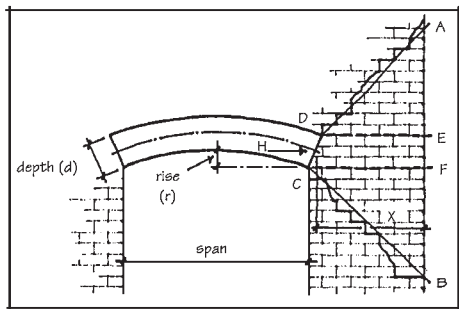


Figure 11-18 Horizontal thrust resistance in masonry arches.
(From BIA Technical Note 31A.)

resistance of the wall to this horizontal force. The diagram in *Fig. 11-18* shows how the resistance is calculated. It is assumed that the arch thrust attempts to move a volume of masonry enclosed by the boundary lines *ABCD*. For calculating purposes, the area *CDEF* is equivalent in resistance. The thrust is thus acting against two planes of resistance, *CF* and *DE*. Resistance is determined by the formula

$$H_1 = v_m n x t \quad (11.8)$$

where H_1 = resisting thrust, lb

v_m = allowable shearing stress in the masonry wall, psi

n = number of resisting shear planes

x = distance from the center of the skewback to the end of the wall, in.

t = wall thickness, in.

By using this principle, the minimum distance from a corner or opening at which an arch may be located is easily determined. To do so, write the formula to solve for x , substituting actual arch thrust for resisting thrust:

$$x = \frac{H}{v_m n t} \quad (11.9)$$

11.2.7 Major Arch Design

Major arches are those with spans greater than 6 ft or rise-to-span ratios of more than 0.15 (see *Figs. 11-19 and 11-20*). The design of these elements is a much more complicated structural problem than minor arches because of increased loading and span conditions. Leontovich's book, *Frames and Arches*, gives formulas for arches with rise-to-span ratios (f/L) ranging from 0.0 to 0.6. These are straightforward equations by which redundant moments and forces in arched members may be determined. The equations are based



Figure 11-19 First National Bank of Fayetteville, Arkansas—Polk, Stanley Gray Architects. (Photo courtesy BIA.)



Figure 11-20 United Bank Tower in Austin, Texas—Zapalac and Associates Architects. (Photo courtesy BIA.)

on a horizontal and vertical grid coordinate system originating at the intersection of the arch axis and the left skewback. Each set of equations depends on the conditions of loading. Moments, shears, and axial thrusts are determined at various increments of the span. No tensile stresses should be permitted in unreinforced masonry arches under static loading conditions. For a detailed analysis of major structural arch design, see Leontovich, *Frames and Arches*. For relatively high-rise, constant-section arches, his Method A of Section 22 applies.

12

STRUCTURAL MASONRY

Extensive structural engineering design is beyond the intended scope of this text. This chapter discusses only the general concepts of masonry bearing wall design. For detailed methods of analysis, design formulas, and sample calculations, the reader should consult Schneider and Dickey's *Reinforced Masonry Design* (1989); Amrhein's *Reinforced Masonry Engineering Handbook* (1992); Drysdale, Hamid, and Baker's *Masonry Structures Behavior and Design* (1999); or the *Masonry Designer's Guide* (Matthys, 1993), based on the Masonry Standards Joint Committee Code and Specifications published by The Masonry Society (TMS).

12.1 MASONRY STRUCTURAL SYSTEMS

The general concept of a masonry bearing wall structure is combined action of the floor, roof, and walls in resisting applied loads. The bearing walls can be considered as continuous vertical members supported laterally by the floor and roof systems. Vertical live loads and dead loads are transferred to the walls by the floor and roof systems acting as horizontal flexural members. The floor and roof systems also act as diaphragms to transfer lateral loads to the walls. Vertical and lateral loads applied from only one side of a wall will induce bending moment. The total moment is a result of the combined loading. Since compressive loads counteract some of the tension from this bending moment, the primary stresses that control loadbearing systems are compression and shear. *Figures 12-1 and 12-2* illustrate the typical forces acting on masonry bearing walls.

12.1.1 Axial Load Distribution

Normal axial load distribution in masonry is based on the units being laid in running bond pattern with a minimum overlap between units of one-fourth the unit length. Units laid in stack bond must be reinforced with bond beams or joint reinforcement to achieve the same distribution of axial loads.

When a superimposed axial load is applied to a masonry wall laid in running bond, it is assumed to be distributed uniformly through a triangular section of the wall (see *Fig. 12-3*). Bearing pads or plates are used to distrib-

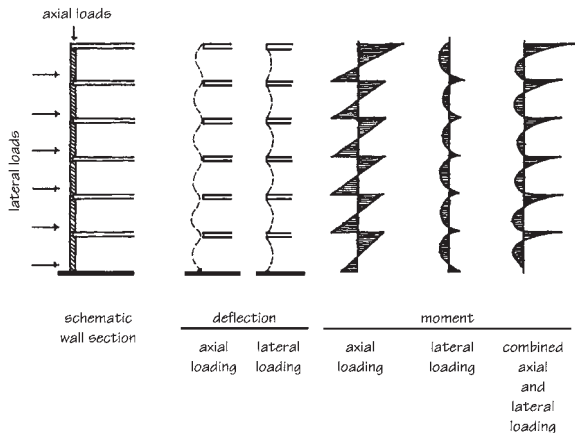


Figure 12-1 Forces acting on a bearing wall.

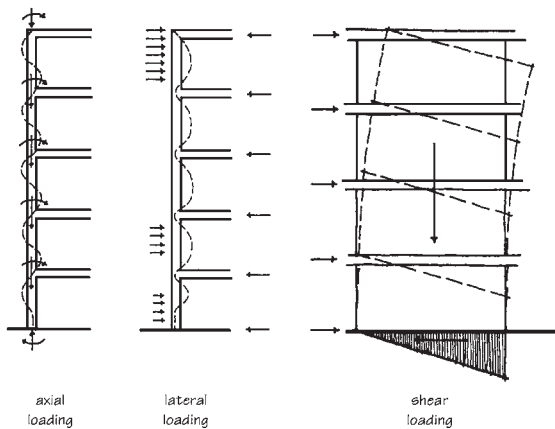


Figure 12-2 Loading on masonry bearing walls and shear walls. (From BIA, Recommended Practice for Engineered Brick Masonry.)

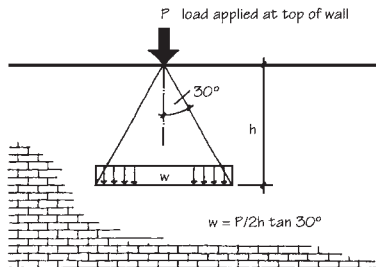


Figure 12-3 Axial load distribution in masonry laid in running bond patterns. (From *BIA, Recommended Practice for Engineered Brick Masonry*.)

ute concentrated load stresses and to permit any slight differential lateral movement which might occur. When a joist, beam, or girder bears directly on a masonry wall, the reaction will not generally occur in the center of the bearing area because deflection of the bearing member moves the reaction toward the inner face of the support. If significant eccentricity develops, the addition of reinforcing steel may be required to resist the tensile bending stresses which result. Multi-wythe walls may be designed with composite or non-composite action between the wythes (see *Fig. 12-4*).

12.1.2 Lateral Load Distribution

Skeleton frame systems transfer lateral loads from wind and seismic forces through rigid connections at column and beam intersections, and through diagonal bracing. This results in a concentration of stresses at joints in the frame and at the foundation. In a bearing wall system, or box frame, the structural floors and walls constitute a series of intersecting planes with the resulting forces acting along continuous lines rather than at intermittent points. The use of masonry in multi-story loadbearing applications is dependent on the cohesive action of the structure as a whole. Floor and roof framing systems must be sufficiently rigid to function as horizontal diaphragms transferring lateral loads to shear walls without excessive in-plane deflection.

Seismic forces are caused by a stress buildup within the earth's crust. An earthquake is the sudden relief of this stress and consequent shifting of the earth mass along an existing fault plane. Primary vibration waves create a push-pull effect on the ground surface. Secondary waves traveling at about half the speed of the primary set up transverse movements at right angles to the first shock. Structures may experience severe lateral dynamic loading under such conditions, and must be capable of absorbing this energy and withstanding the critical temporary loading of seismic ground motion.

Framing systems designed to withstand seismic and high wind loads may be either *flexible structures* with low damping characteristics, such as concrete and steel frame buildings, or *rigid structures* with high damping, such as masonry buildings.

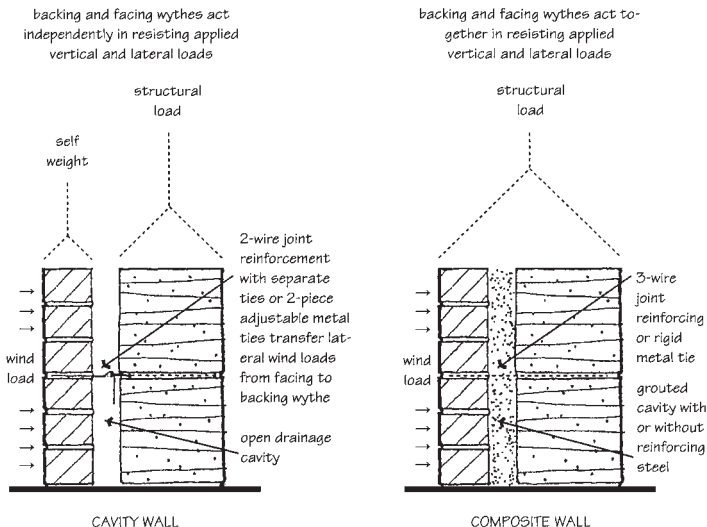


Figure 12-4 Load distribution in multi-wythe masonry walls.

Damping is the ability of a structure to diminish its amplitude of vibration with time through dissipation of energy by internal frictional resistance. It is generally recognized that structural response to earthquake motion is influenced by the building's fundamental period of vibration (the time it takes to complete its longest cycle of vibration). Low-rise masonry buildings typically have fundamental periods of vibration of 0.3 second or less, compared to 0.6 second for low-rise flexible frame buildings. The damping effect of masonry construction and its resulting low period of vibration accounted for good performance of many low-rise masonry buildings in the 1985 Mexico City earthquake, which registered 8.1 on the Richter scale. The soft clay soil under the city caused long-lasting ground motions with long periods of vibration. Such movements collapsed many buildings of 5 to 20 stories in height that had long periods of vibration in the same range as those of the ground motion. Base motions were greatly amplified in the upper stories of these buildings because the similar periods of vibration set up a condition of resonance. Rigid, low-rise masonry structures, however, including many unreinforced historic structures, suffered little damage.

Different soil and rock conditions produce different periods of ground motion, but the capacity of masonry structures to absorb seismic energy through damping is such that unit stresses remain extremely low, factors of safety very high, and damage negligible.

Steel and concrete skeleton frames are generally classified as moment-resisting space frames in which the joints resist forces primarily by flexure. This flexibility, although effective in dissipating the energy of the seismic loads, can cause substantial secondary, non-structural damage to windows, partitions, piping, and mechanical equipment. Structural frame buildings “ride” through an earthquake because they can deflect in response to loads, but such deflection breaks glass and damages plaster, drywall partitions, stairs, mechanical piping, and other costly and potentially dangerous elements.

Loadbearing masonry buildings are classified as rigid box frames in which lateral forces are resisted by shear walls. A box frame structural system must provide a continuous and complete path for all of the assumed loads to follow from the roof to the foundation, and vice versa. This is achieved through the interaction of floors and walls securely connected along their planes of intersection. Lateral forces are carried by the floor diaphragms to vertical shear walls parallel to the direction of the load. The shear walls act as vertical cantilevered masonry beams subject to concentrated horizontal forces at floor level, and transfer these lateral forces to the foundation by shear and flexural resistance. The amount of horizontal load carried by a shear wall is proportional to its relative rigidity or stiffness. The rigidity of a shear wall is inversely proportional to its deflection under unit horizontal load, and resistance is a function of wall length. The load transfer induces shear stresses in the wall.

12.1.3 Diaphragms

A roof or floor diaphragm must have limited deflection in its own plane in order to transmit lateral forces without inducing excessive tensile stress or bending in the walls perpendicular to the direction of the force. The stiffness of the diaphragm also affects the distribution of lateral forces to the shear walls parallel to the direction of the force (see Fig. 12-5). No diaphragm is infinitely rigid, and no diaphragm capable of carrying loads is infinitely flexible. For the purposes of analysis, diaphragms are classified as *rigid*, *semirigid* or *semiflexible*, or *flexible*. Cast-in-place concrete and flat precast concrete slabs are considered rigid. Steel joists with structural concrete deck are considered semirigid or semiflexible, and steel or wood joists with wood decking are considered flexible. Rigid and semirigid diaphragms do not experience excessive deflection under load. They distribute lateral loads to the shear walls in proportion to their relative rigidity compared to that of the walls.

Diaphragms may be constructed of concrete, wood, metal, or combinations of materials. Design criteria for materials such as steel and reinforced concrete are well known and easily applied once the loading and reaction conditions are known. Where a diaphragm is made up of distinct units such as plywood panels, precast concrete planks, or steel deck sections, its characteristics are dependent largely on methods of attachment to one another and to supporting members. Such attachments must resist shearing stresses and provide proper anchorage to the supporting shear walls.

12.1.4 Masonry Shear Walls

The lateral load absorbed by a floor or roof diaphragm is transferred to shear walls. Shear walls are designed to resist lateral forces applied parallel to the plane of the wall (see Fig. 12-6). Shear walls perform best when they are also

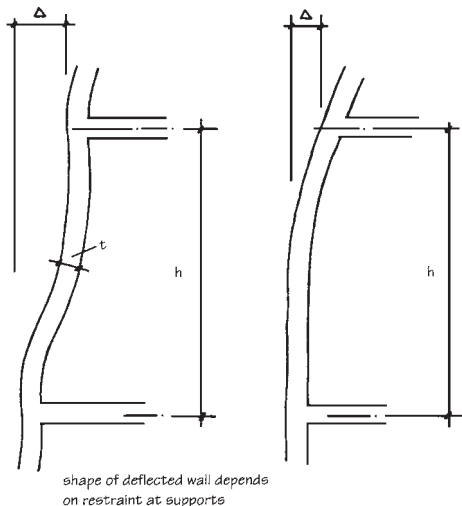


Figure 12-5 Diaphragm deflection limitations. (From BIA Technical Note 24C.)

loadbearing, because the added loading offers greater resistance to overturning moments. The orientation of the bearing walls in a building can minimize lateral load stresses and take advantage of the natural compressive and shear resistance of the masonry. If all of the bearing walls in a building are oriented in one direction, they will resist lateral loads only in that direction, and additional non-bearing shear walls may be needed in other orientations. Two-directional and multi-directional wall configurations can resist lateral loads and shear from more than one direction. Both loadbearing and non-loadbearing shear walls can be stiffened by adding flanges that have a positive connection to the intersecting shear walls.

If analysis indicates that tension will be developed in unreinforced masonry shear walls, the size, shape, or number of walls must be revised, or the walls must be designed as reinforced masonry.

The lateral load resistance of masonry structures is basically a function of the orientation, area, and strength of the shear walls. If the cumulative area of shear wall is sufficient, the building can elastically resist even strong earthquakes without reaching the yield point of the steel reinforcement.

Some of the most important aspects of shear wall and seismic design are qualitative elements regarding symmetry and location of resisting members, relative deflections, anchorage, and discontinuities. Shear walls resist horizontal forces acting parallel to the plane of the wall through resistance to

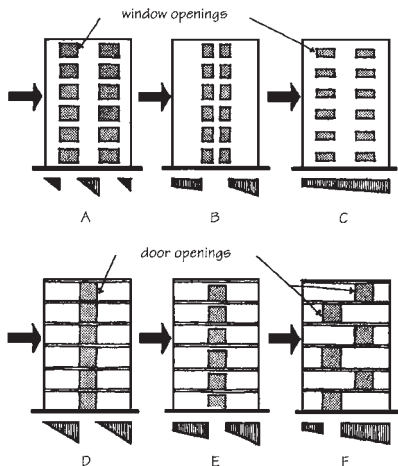


Figure 12-6 Shear walls resist lateral load applied parallel to plane of wall. (From BIA Technical Note 24C.)

overturning and shearing resistance. The location of shear walls in relation to the direction of the applied force is critical. Since ground motion may occur in perpendicular directions, the location of resisting elements must coincide with these forces. Shear walls may be either loadbearing or non-loadbearing elements. It is best to combine the functions of such members and, whenever possible, design the building with both transverse and longitudinal loadbearing shear walls. Designing all the loadbearing walls to resist lateral forces improves overall performance because the increased number of shear walls distributes the load and lowers unit stresses. Shear walls that are also loadbearing have greater resistance to seismic forces because of the stability provided by increased axial loads.

If loadbearing walls also function as shear walls, then general building layout becomes a very important aspect of seismic design. The building shear wall layout should be symmetrical to eliminate torsional action. Several compartmented floor plans are shown in *Figs. 12-7 and 12-8*. The regular bay spacing lends itself to apartment, hotel, hospital, condominium, and nursing home occupancies, where large building areas are subdivided into smaller areas. By changing the span direction of the floor, shear walls in two or more directions can become loadbearing. The radial walls of the round building can actually absorb seismic shocks from any direction and dissipate the earthquake energy with very low levels of stress. In skeleton frame buildings, elevator and stair cores of concrete or masonry are often used as shear walls even though they may not have axial loadbearing capacity.

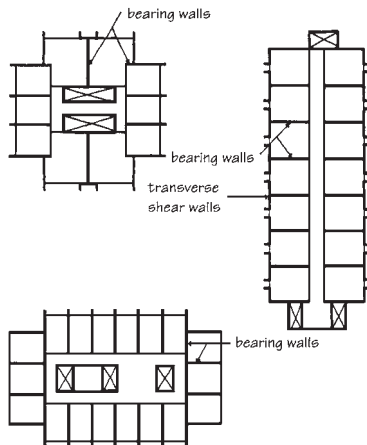


Figure 12-7 Examples of loadbearing walls oriented in two directions and functioning as shear walls to resist lateral loads in those directions.

Providing a good balance between the amount of shear wall along each of the principal building axes will provide greatest economy and best performance. It is also best to design wall lengths that are uniform between openings, and to provide wall returns or flanges wherever possible so that variations in relative rigidity are minimized and maximum shear is decreased.

One method of increasing the stiffness of shear walls as well as their resistance to bending is the use of intersecting walls or flanges (see *Fig. 12-9*). Although the effective length of flanges is limited, walls with L, Z, I, or C shapes have better flexural resistance for loads applied perpendicular to their flange surface. Shear stresses at the intersection of the walls are dependent on the type of bonding used to tie the two elements together.

Another method that may be used to increase the stiffness of a bearing wall building is the coupling of co-planar shear walls. The illustrations in *Fig. 12-6* indicate the effect of coupling on stress distribution from forces parallel to the wall. In parts A and D, a flexible connection between the walls is assumed so that they act as independent vertical cantilevers in resisting the lateral loads. Walls B and E assume the elements to be connected with a more rigid member, capable of shear and moment transfer, so that a frame-type action results. This connection may be made with a steel, reinforced concrete, or reinforced masonry section. The plate action in parts C and F assumes an extremely rigid connection between walls, such as full-story-height sections or deep rigid spandrels.

The type of floor-to-wall connection also influences the transfer of stress, and many seismic failures in masonry buildings occur because of

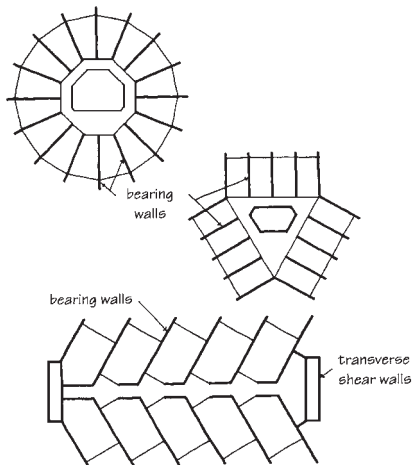


Figure 12-8 Examples of loadbearing walls oriented in multiple directions and functioning as shear walls to resist lateral loads in those directions.

inadequate connections. When the various elements of a structure are rigidly connected to one another and one element is deflected by a force, the other elements must move equally at the point of connection or failure will occur somewhere in the system.

Analysis of the damage to masonry walls caused by earthquake stress shows that cracks in shear walls typically follow a diagonal path. The plane of failure extends from near the top corner, where the maximum load is applied, diagonally downward toward the bottom support (see Fig. 12-10). This is the same mode of failure produced by diagonal tension or racking tests, in which 4×4 -ft masonry panels are subjected to diagonal loading at opposing corners. Shear strength at the joints is independent of unit properties such as initial rate of absorption, but it is affected by mortar type, compressive strength, and workmanship. Since the failure is in tension, masonry with weak mortar bond also has low diagonal tensile or shear strength. Failure, however, occurs without explosive popping or spalling of unit faces. The steel reinforcement holds the wall together after a shear failure to prevent the panel from separating after joint cracking occurs. This stability under maximum stress prevents catastrophic structural failure and increases the factor of safety in the aftermath of seismic disturbances.

Where masonry is used as non-loadbearing infill panels in steel or concrete frame structures, this diagonal shear strength increases the building's lateral stiffness (see Fig. 12-11). In the 1985 Mexico City earthquake, medium- and high-rise reinforced concrete frame structures with masonry infill performed much better than similar buildings without masonry infill. Even

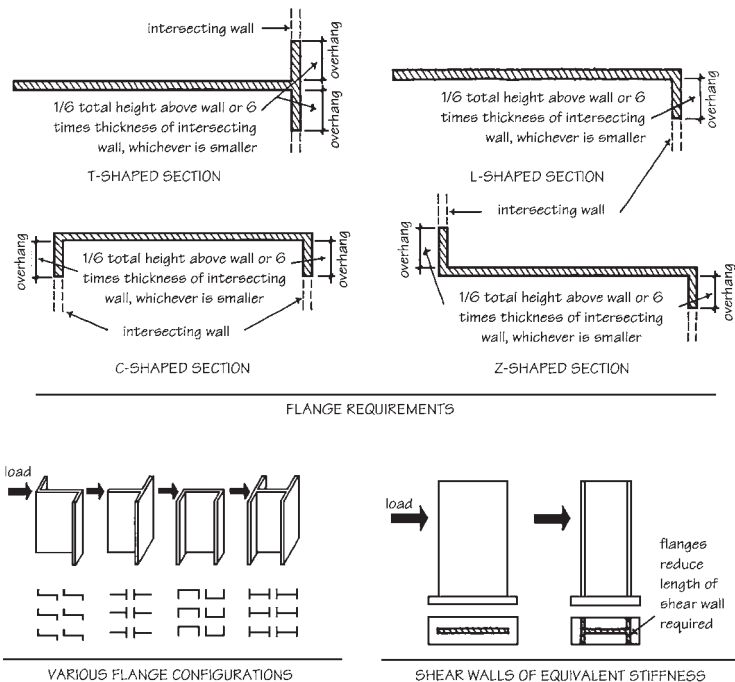


Figure 12-9 Shear walls with flanges. (From Brick Industry Association, Technical Note 24C, BIA, Reston, VA; and National Concrete Masonry Association, Design Manual—The Application of Non-Reinforced Concrete Masonry Load-Bearing Walls in Multistory Structures, NCM, Herndon, VA.)

when the infill panels served only as a backup for veneer systems and were not designed as structural elements, were not reinforced, and were not correctly anchored to the surrounding frames, they absorbed large amounts of seismic energy, and in many cases apparently prevented structural collapse. When infilling was omitted in lower stories to provide access to retail businesses, the buildings proved more susceptible to damage at the lower levels. Corner buildings in which the masonry infill was omitted on two sides for retail access suffered severe damage. Investigators also found masonry infill panels to have increased the strength and resistance of nearby buildings when the World Trade Center Buildings collapsed after the terrorist attacks. Many buildings, including older and historic structures, withstood the

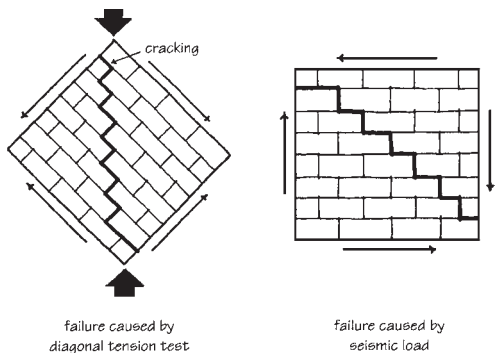


Figure 12-10 Diagonal tension.

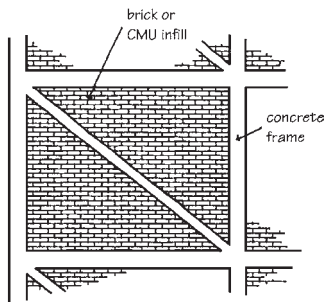


Figure 12-11 Masonry infill panels.

impact of heavy debris as well as the concussive force of the large air mass produced as the towers fell.

12.1.5 Beams and Girders

The use of reinforcing steel in masonry construction permits the design of flexural masonry members such as lintels, beams, and girders to span horizontal openings (see Fig. 12-12). This gives a continuity of materials, finishes, and fire ratings by eliminating the introduction of other materials solely for flexural spans.

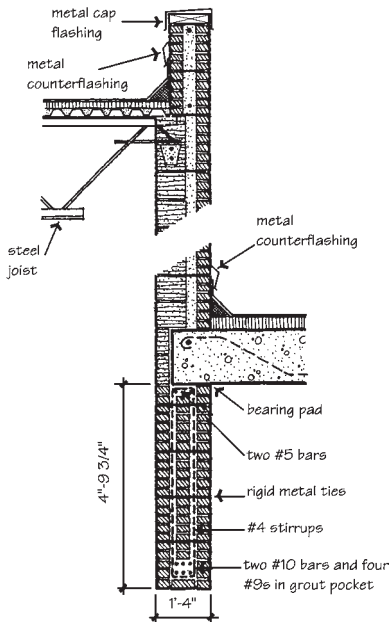


Figure 12-12 Example of reinforced masonry beam.

The design of reinforced masonry beams and girders is based on the straight-line theory of stress distribution. The required steel is determined by actual calculated stress on the member. The reinforcement needed to resist this stress is then provided in the necessary amounts and locations. The member must be designed to resist at all sections the maximum bending moment and shears produced by dead load, live load, and other forces determined by the principles of continuity and relative rigidity. Building codes place deflection limits on all flexural members which support unreinforced masonry.

The concept of deep masonry wall beams is based on a wall spanning between columns or footings instead of having continuous line support at the bottom as in conventional loadbearing construction (see Fig. 12-13). If soil-bearing capacities permit this type of concentrated load, the wall may be designed as a flexural member and must resist forces in bending rather than in direct compression.

Deep wall beams may also be used to open up the ground floor of a load-bearing structure. The bearing wall on the floor above can be supported on

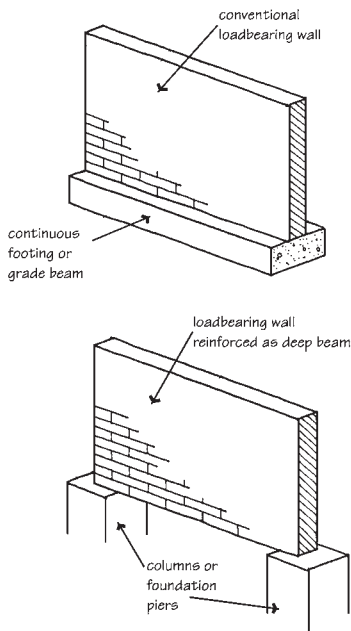


Figure 12-13 Deep wall beams. (From *Schneider and Dickey, Reinforced Masonry Design, 2nd ed., Prentice-Hall, 1987.*)

columns to act as a deep wall beam and transfer its load to the supports. This alternative permits the design of larger rooms and open spaces that might not be possible with regularly spaced bearing walls. Bearing walls, non-bearing walls, and shear walls may all use this principle to advantage in some circumstances.

12.1.6 Connections

The box frame system of lateral load transfer requires proper connection of shear walls and diaphragms. Connections may be required to transmit axial loads, shear stresses, and bending moments acting separately or in combination with one another. Connections can be made with anchor bolts, reinforcing dowels, mechanical devices, or welding, and may be either fixed or hinged. Although neither complete restraint nor a completely hinged

condition actually exists, these assumptions may be made for purposes of calculation. Each individual condition will dictate the type of connection needed, and a variety of solutions can usually be designed for a given problem. The design and detailing of structural connections are covered in depth in the engineering texts listed at the beginning of this chapter. *Figures 12-14 through 12-20* show some examples of floor and roof system connections.

12.1.7 Foundations

Although the weight of a loadbearing structure is greater than that of a similar frame building, the required soil-bearing capacity is often less because the bearing walls distribute the weight more evenly. Bearing wall structures are compatible with all of the common types of foundations, including grade beams, spread footings, piles, caissons, and mats. Foundation walls below grade may be of either concrete or masonry, but must be doweled to the footing to assure combined action of the wall and the foundation.

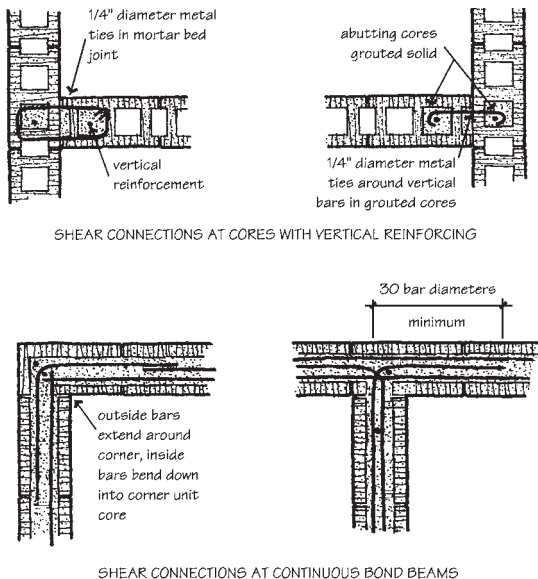
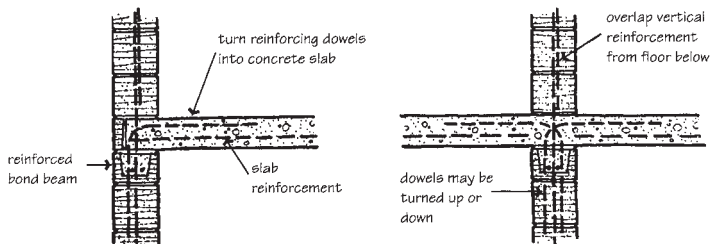
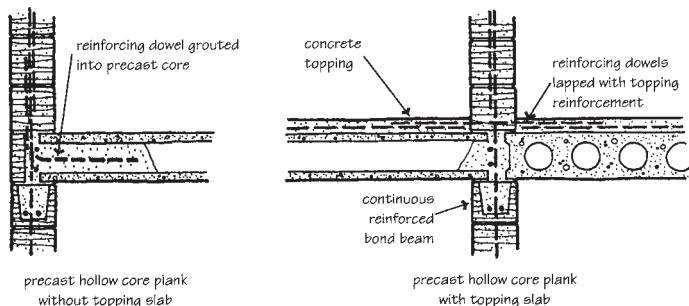


Figure 12-14 Steel reinforcing at intersecting single-wythe masonry walls.



EXAMPLES OF CMU WALL CONNECTIONS TO CAST-IN-PLACE CONCRETE



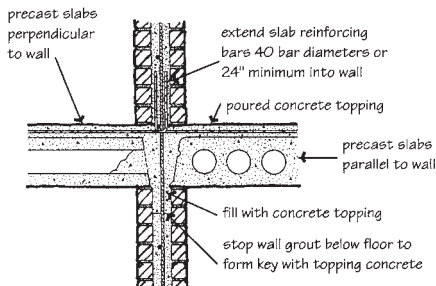
EXAMPLES OF CMU WALL CONNECTIONS TO PRECAST CONCRETE

Figure 12-15 Connecting single-wythe masonry walls to precast and cast-in-place concrete floors and roofs.
 (From Schneider and Dickey, *Reinforced Masonry Design*, 2nd ed., Prentice-Hall, 1987.)

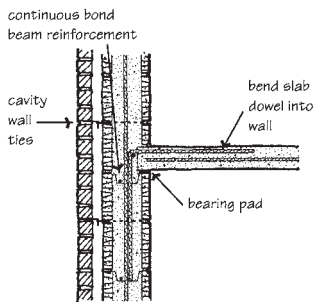
12.1.8 Reinforced and Unreinforced Masonry

Plain masonry contains no reinforcing steel that is designed to resist applied loads. It is very strong in compression, but weak in tension and shear. Small lateral loads and overturning moments are resisted by the mass of the wall, but if lateral loads are higher, resistance to shear and flexural stresses is limited by the bond between mortar and units and the precompression effects of vertical loading. Shearing stresses in bearing wall buildings, however, seldom control the wall type and thickness. Although flexural stresses may sometimes control the design of non-bearing and shear walls, compressive stresses generally govern in loadbearing structures.

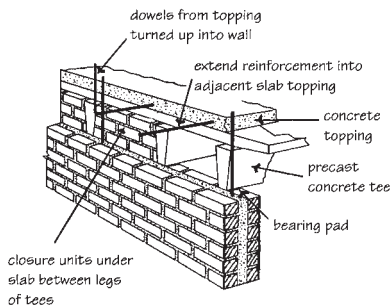
Where lateral loads are a significant factor in the design of structural masonry, flexural strength can be increased by placing steel reinforcement in mortar bed joints, bond beams, grouted cells, or cavities. The hardened mor-



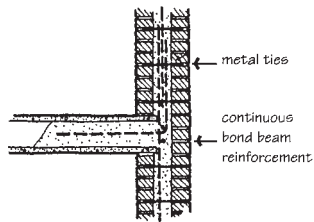
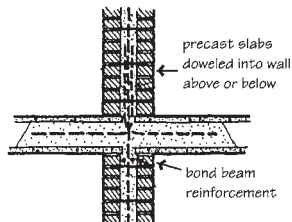
PRECAST HOLLOW SLAB FLOOR WITH TOPPING SLAB



PRECAST CONCRETE SLAB



PRECAST DOUBLE TEE



PRECAST HOLLOW SLAB FLOORS WITHOUT TOPPING SLAB

Figure 12-16 Connecting double-wythe masonry walls to precast concrete floors and roofs. (Adapted from *Amrhein, Reinforced Masonry Engineering Handbook, 5th ed., Masonry Institute of America, Los Angeles, 1992.*)

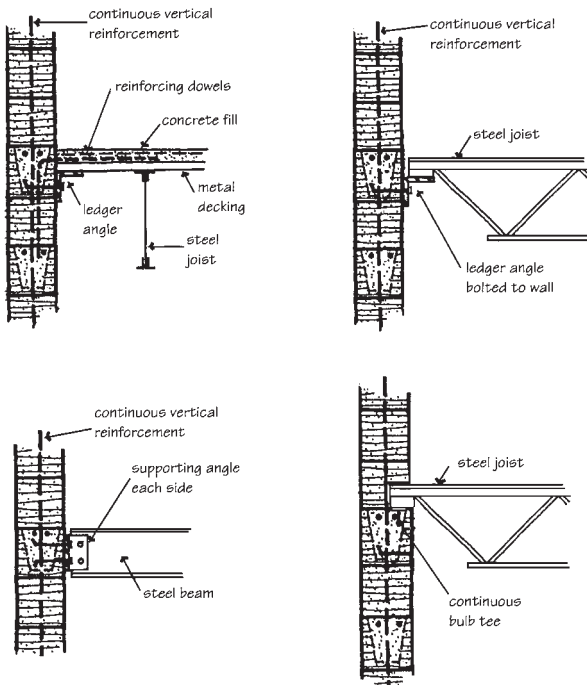


Figure 12-17 Examples of single-wythe masonry wall connections to steel beams and open web steel joists.

tar and grout bind the masonry units and steel together so that they act as a single element in resisting applied forces. Reinforcement may be added to resist isolated stresses wherever design analysis indicates that excessive flexural tension is developed. The reinforcing steel is then designed to resist all of the tensile stresses and the flexural strength of the masonry is neglected entirely.

12.1.9 Empirical and Analytical Design

The analytical design of loadbearing masonry buildings by the allowable stress method, the strength design method, or prestressed masonry design is based on a general analysis of the structure to determine the magnitude, line

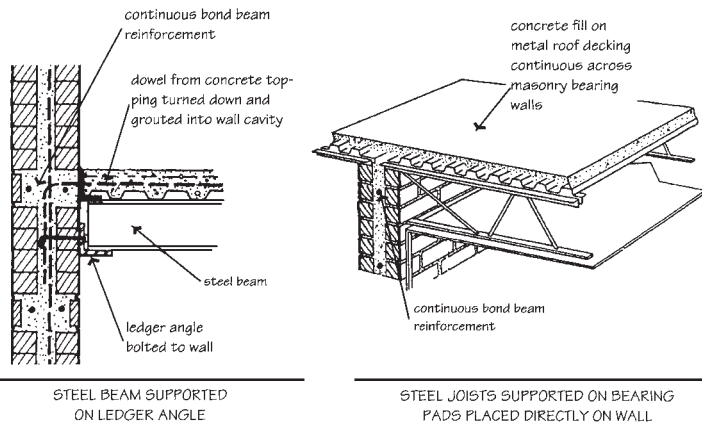
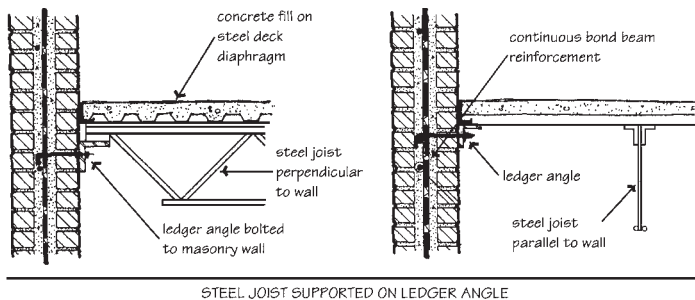


Figure 12-18 Connecting double-wythe masonry walls to steel beams and joists. (Adapted from Amrhein, Reinforced Masonry Engineering Handbook, 5th ed., Masonry Institute of America, Los Angeles, 1992.)

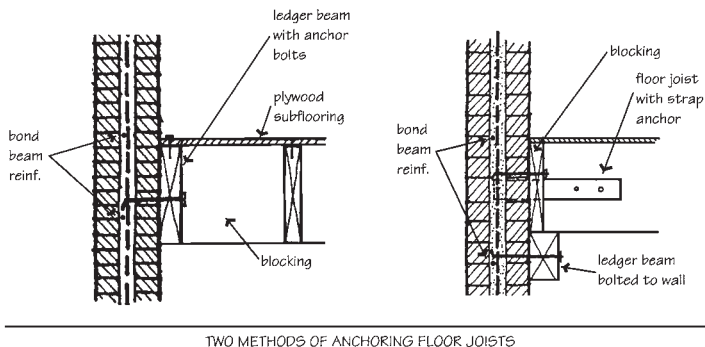
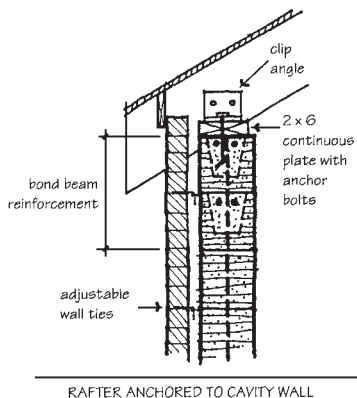
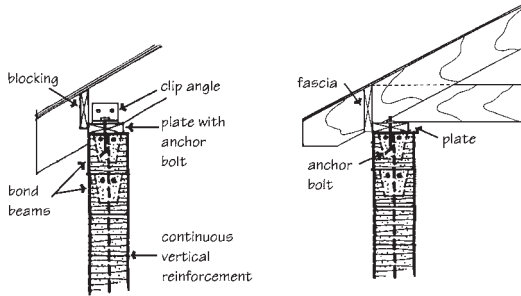
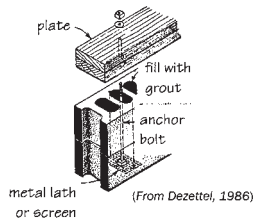
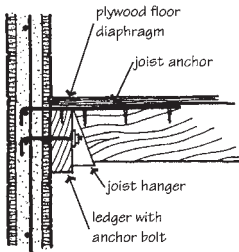


Figure 12-19 Connecting double-wythe masonry walls to wood frame floors and roofs.

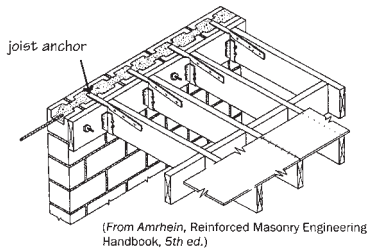
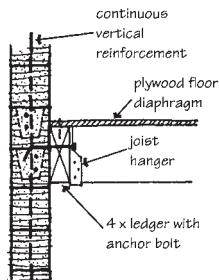
of action, and direction of all forces acting on the various members. All dead loads, live loads, lateral loads, and other forces, such as those resulting from temperature changes, impact, and unequal settlement, are considered. The combinations of loads that produce the greatest stresses are used to size the members. The performance of loadbearing masonry walls, pilasters, and columns can be predicted with reasonable accuracy using allowable stress methods, but the design will be conservative and less economical than if the strength method is used. The complexity of the analysis will depend on the



EXAMPLES OF CMU WALL CONNECTIONS TO WOOD ROOF FRAMING



ANCHOR BOLT DETAIL



EXAMPLES OF CMU WALL CONNECTIONS TO WOOD FLOOR FRAMING

Figure 12-20 Connecting single-wythe masonry walls to wood floor and roof framing.

complexity of the building with respect to height, shape, wall location, and openings in the wall.

While empirical design is restricted by arbitrary limits on the ratio of wall height to thickness, analytical design determines the actual thickness required to resist service loads on walls of any desired height. Empirical design codes arbitrarily dictate the spacing of lateral supports, but analytical design calculates loads and provides lateral support as needed to resist specific forces and provide stability. The allowable stress method of analytical design establishes allowable compressive stresses based on the general characteristics of the units and mortar selected, the slenderness of the wall, and the eccentricity of applied loads. Both the allowable stress and strength design methods also take into account shear and flexural stresses, which are not considered in empirical design.

Empirical design methods may be used for low-rise buildings, but analytical design will produce more efficient and economical results for both unreinforced and reinforced masonry. Empirical requirements are essentially only rules of thumb, and are very simplistic in their application. Height- or length-to-thickness ratios are used in conjunction with minimum wall thicknesses to determine the required section of a given wall. Analytical design by the allowable stress method is based on the properties of the component materials in resisting calculated stresses but also includes some arbitrary empirical limits. Strength design is fully analytical in its methodology and does not rely on any empirical limitations. The application of strength design methods has finally brought masonry into the modern era alongside concrete and steel engineering, and will yield the most efficient and economical designs for both low-rise and high-rise structures.

12.1.10 Code Requirements

Design requirements for both the empirical and analytical methods are governed by the Masonry Standards Joint Committee (MSJC) *Building Code Requirements for Masonry Structures* (ACI 530/ASCE 5/TMS 402) and *Specifications for Masonry Structures* (ACI 530.1/ASCE 6/TMS 602), which are written jointly by the American Concrete Institute (ACI), the American Society of Civil Engineers (ASCE), and The Masonry Society (TMS). Sometimes referred to simply as ACI 530, the MSJC Code also forms the basis of the *International Building Code*, and is referenced in it throughout.

12.2 EMPIRICAL DESIGN

Masonry buildings built before the twentieth century, including all historic masonry buildings throughout the world, are unreinforced, empirically designed structures. These traditional loadbearing designs used massive walls and buttresses to resist lateral loads, including those induced by roof thrusts, arches, and large domes. Empirically designed masonry today is limited to buildings of modest height where wind loads are low and seismic loading is not a consideration.

Empirical design is based on historical precedent and rules of thumb rather than detailed analysis of loads and stresses, and calculated structural response. Empirically designed buildings do not incorporate reinforcing steel for load resistance, but may include joint reinforcement for control of shrinkage cracking and thermal movement. Elements that do not contribute to the primary lateral force-resisting system in masonry structures, and masonry elements in steel or concrete frame buildings, may be designed empirically under the MSJC Code.

Under the MSJC Code, empirically designed buildings are prohibited in Seismic Performance Categories D and E and in areas where design wind loads exceed 25 psf. In Seismic Performance Categories B and C, empirically designed masonry may not be part of the lateral force-resisting system. The height of empirically designed buildings which rely on masonry walls for lateral load resistance is limited to 35 ft above the foundation or supporting element.

12.2.1 Allowable Compressive Stresses

The MSJC Code lists allowable compressive stresses for empirically designed masonry which vary with unit and mortar type. Service loads must be limited so that the maximum average compressive stress in the wall does not exceed the allowable values. To determine compressive stresses in the masonry, the combined effects of vertical dead loads plus live loads (exclusive of wind and seismic forces) must be considered.

12.2.2 Lateral Support Requirements

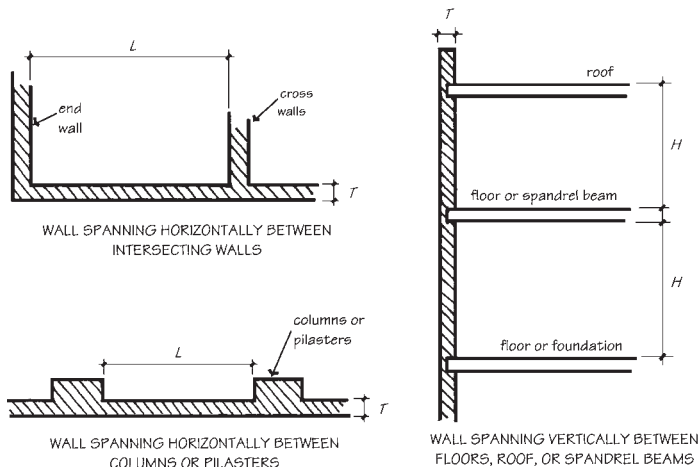
In lieu of analytical design, prescriptive requirements are given for the ratio of the unsupported height or length to the nominal thickness of masonry bearing walls and non-bearing partitions. Lateral support must be provided in either the horizontal or the vertical direction within the limits shown in *Fig. 12-21*. Cross walls, pilasters, buttresses, columns, beams, floors, and roofs may all be used to provide the required support. Typical configurations for unreinforced masonry pilasters are shown in *Fig. 12-22*. Typical reinforced single-wythe columns are shown in *Fig. 12-23*. Lateral support connections at intersecting walls can be made in a number of different ways, since they do not have to transfer shear loads (see *Fig. 12-24*).

Lateral support gives the wall sufficient strength to resist wind loads and other horizontal forces acting either inward or outward. Members providing lateral support must be adequately bonded or anchored to the masonry, and must be capable of transferring forces to adjacent structural members or directly to the ground. Pilasters may be either bonded into the wall, connected with rigid metal ties, or connected across a continuous movement joint with adjustable metal ties.

The minimum cumulative length of shear walls in each required direction, exclusive of openings, must be 40% of the long dimension of the building (see *Fig. 12-25*). The required spacing of shear walls is based on the type of floor and roof provided, because diaphragm rigidity varies with each system. Stiffer elements permit wider spacing (see *Fig. 12-26*). Shear walls must have a minimum nominal thickness of 8 in. In composite walls, the thickness is measured as the nominal thickness of the two wythes plus the mortared collar joint or grouted cavity. In cavity walls, thickness is measured as the nominal dimension of the shear-resisting wythe only (see *Fig. 12-27*).

12.2.3 Wall Thickness

Bearing walls of one-story buildings must have a nominal thickness of 6 in. Bearing walls of buildings more than one story in height must have a nominal thickness of 8 in. Parapet walls must also be 8 in. thick, and their height is limited to three times the nominal thickness (taller parapets must be designed



Empirical Span-to-Thickness Ratios for Lateral Support of Masonry Walls	
Wall or Element	Maximum Unsupported Height or Length to Nominal Thickness (L/T or H/T)
Bearing walls	
solid or grouted solid	20
all other walls	18
Non-bearing walls	
exterior	18
interior	36

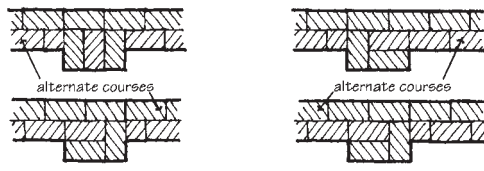
(Based on requirements of the MSJC Building Code Requirements for Masonry Structures ACI 530/ASCE 5/TMS 402, and International Building Code 2003)

Figure 12-21 Lateral support requirements for empirically designed masonry.

analytically). Foundation walls must meet the thickness requirements shown in Chapter 13, and must be constructed with Type M or Type S mortar. If wall height, lateral support, or unbalanced fill conditions exceed code limits, foundation walls must be designed analytically rather than empirically.

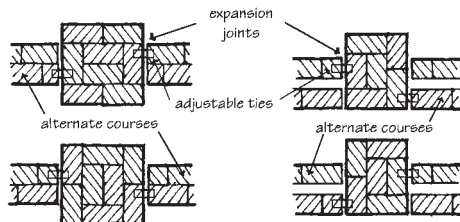
12.2.4 Bonding

Multi-wythe walls may be bonded with masonry headers (see Fig. 12-28), metal ties (see Figs. 12-29 and 12-30), or prefabricated joint reinforcement (see Figs. 12-29 and 12-30). Spacing requirements are different for rigid and



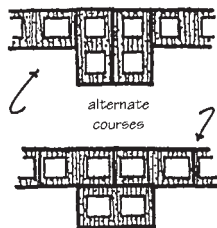
MASONRY UNIT BONDED BRICK PILASTERS

Pilasters connected to walls with unit bonding or rigid metal ties do not accommodate clay masonry expansion. Movement must be accommodated at other locations to prevent cracking.

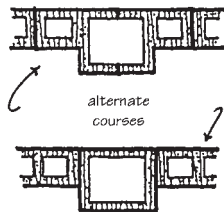


ADJUSTABLE METAL-TIE BONDED BRICK COLUMNS

Adjustable ties and expansion joints are required to accommodate clay masonry expansion. Supporting elements function as unreinforced columns rather than pilasters.

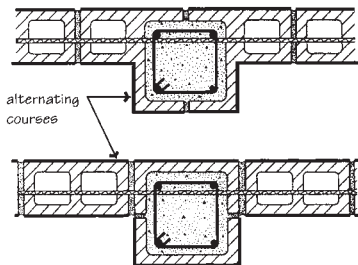


CMU PILASTER BUILT WITH STRETCHER UNITS

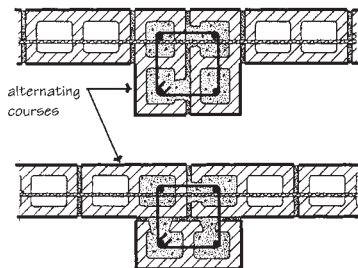


CMU PILASTER BUILT WITH HALF-PILASTER UNITS

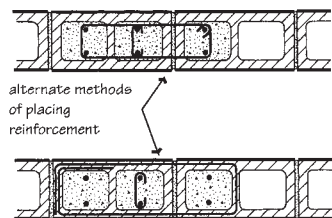
Figure 12-22 Unreinforced columns and pilasters for lateral support of empirically designed masonry walls.



REINFORCED COLUMNS BUILT WITH PILASTER UNITS



REINFORCED COLUMNS BUILT WITH STANDARD STRETCHER UNITS



FLUSH WALL COLUMNS

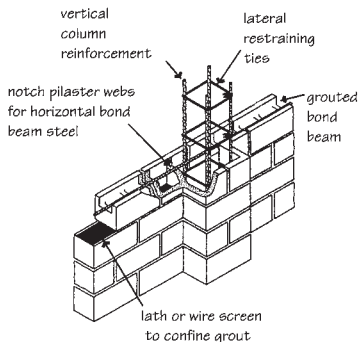


Figure 12-23 Reinforced masonry columns. (From Amrhein, Reinforced Masonry Engineering Handbook, 5th ed., Masonry Institute of America, Los Angeles, 1992.)

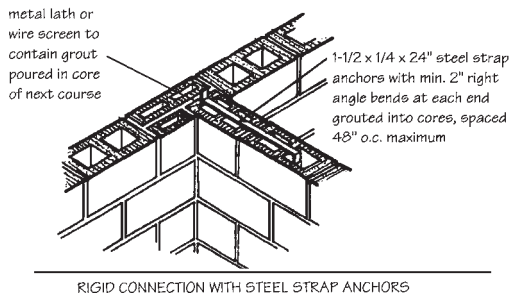
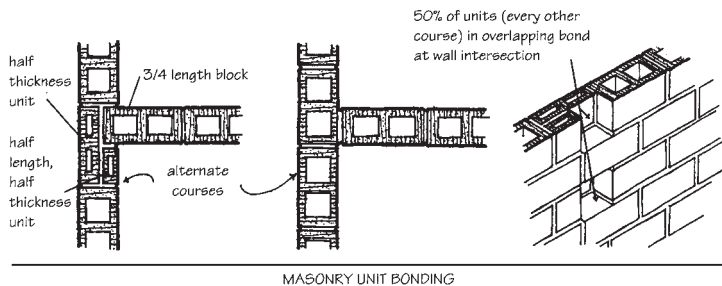
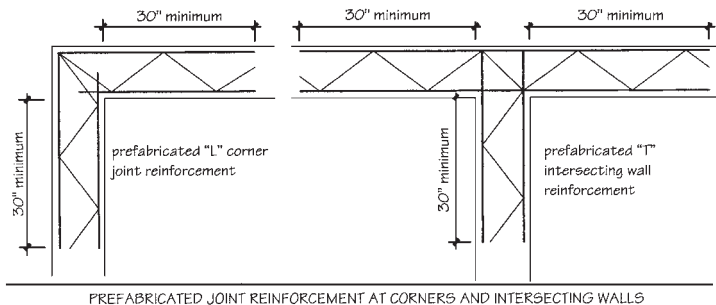
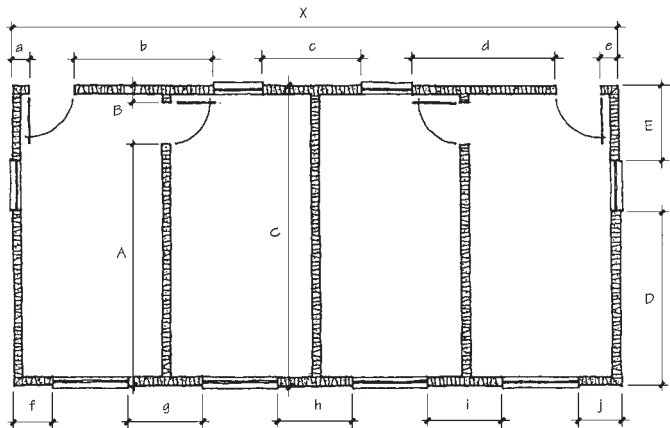


Figure 12-24 Lateral support connections at intersecting single-wythe masonry walls.



walls in long dimension of building: $a + b + c + d + e + f + g + h + i + j \geq 0.4X$

walls in short dimension of building: $A + B + C + A + B + D + E + D + E \geq 0.4X$

Figure 12-25 Shear wall requirements for empirically designed masonry. (Based on requirements of the Masonry Standards Joint Committee, Building Code Requirements for Masonry Structures, ACI 530/ASCE 5/TMS 402, and International Building Code 2003.)

adjustable ties. Ties in alternating courses must be staggered horizontally. Additional ties must be provided at all openings, spaced not more than 3 ft apart around the perimeter, and within 12 in. of the opening itself. Prefabricated wire joint reinforcement used to provide bond between multiple wythes must have cross wires of 9-gauge steel that are spaced a maximum of 16 in. on center. Spacings for joint reinforcement with three rigid wires are the same as for rigid ties, and for joint reinforcement with eye-and-pintle or loop-and-tab-type ties, the same as for adjustable ties.

12.2.5 Corbeling

Only solid masonry units may be used for corbeling. The maximum corbeled projection beyond the face of the wall is limited to one-half the wall thickness for solid walls, or one-half the wythe thickness for cavity walls. The maximum projection of any individual unit may not exceed half the unit height or one-third its thickness (see Fig. 12-31).

12.3 ANALYTICAL DESIGN In the allowable stress method of design, computed stresses resulting from service loads may not exceed allowable stresses dictated by the code. The allowable stresses used are quite conservative, generally resulting in safety

Floor or Roof Construction	Maximum Ratio of Shear Wall Spacing to Shear Wall Length
Cast-in-place concrete	5:1
Precast concrete	4:1
Metal deck with concrete fill	3:1
Metal deck with no fill	2:1
Wood diaphragm	2:1

Figure 12-26 Shear wall spacing for empirically designed masonry. (From *Masonry Standards Joint Committee, Building Code Requirements for Masonry Structures, ACI 530/ASCE 5/TMS 402 and International Building Code 2003.*)

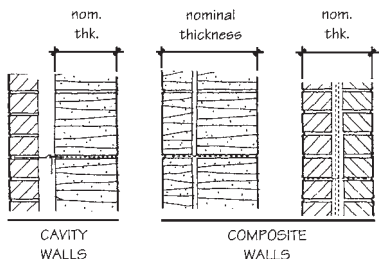


Figure 12-27 Shear wall thickness.

factors which range from 3 to 5. In order to use either the allowable stress or strength design methods, the masonry construction must be inspected in accordance with code requirements (see Chapter 17). Inspection is required to evaluate quality and acceptability of materials, equipment, and procedures. There is no option for uninspected work.

All allowable stress design requirements are based on units laid in running bond with a minimum overlap between units of one-fourth the unit length. Units laid in stack bond must be reinforced with bond beams or prefabricated joint reinforcement spaced 48 in. on center vertically, and the minimum area of steel must equal 0.00028 times the vertical cross-sectional area of the wall.

In determining stresses, the effects of all dead and live loads must be taken into account, and stresses must be based on actual rather than nominal dimensions. Consideration must be given to the effects of lateral load, eccentricity of vertical load, non-uniform foundation pressure, deflection, and

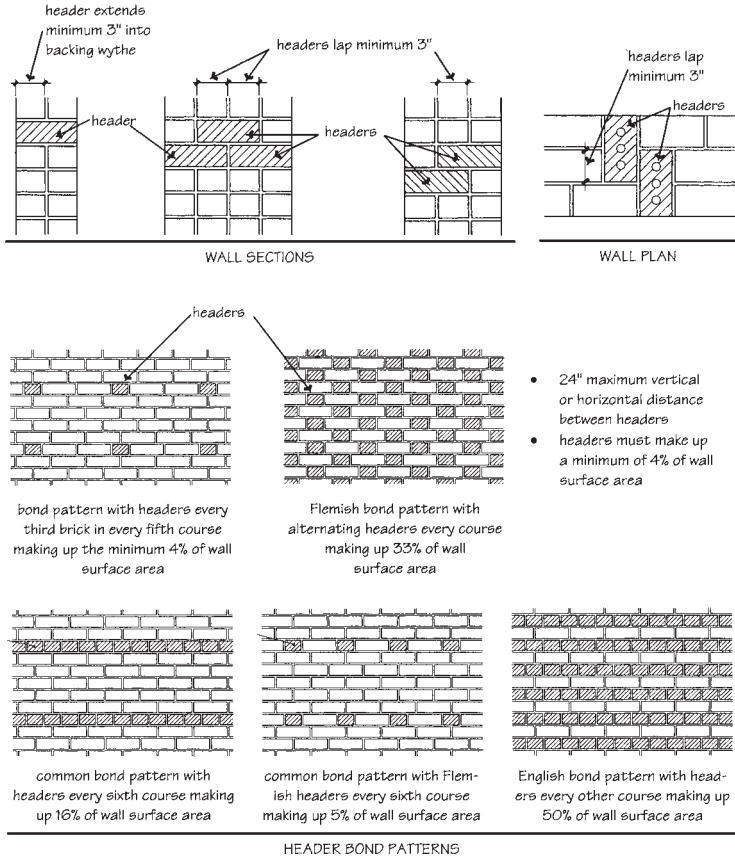


Figure 12-28 Header spacing for masonry-bonded multi-wythe walls. (Adapted from Patterson, Illustrated 2000 Building Code Handbook, McGraw-Hill, New York, 2001.)

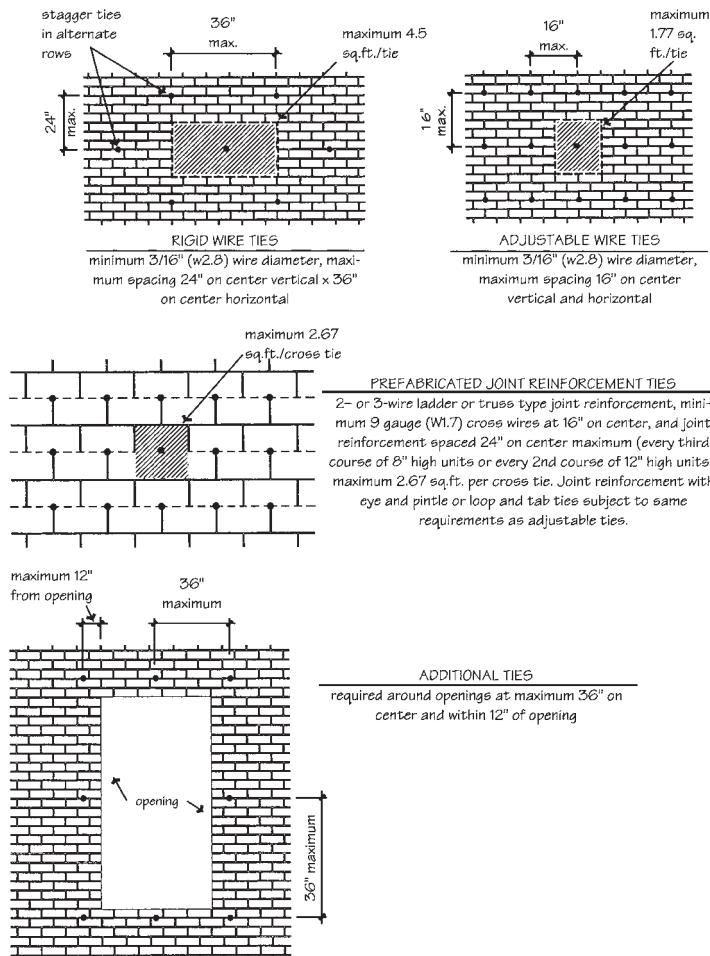


Figure 12-29 Metal tie spacing in multiwythe masonry walls. (Adapted from Patterson, Illustrated 2000 Building Code Handbook, McGraw-Hill, New York, 2001.)

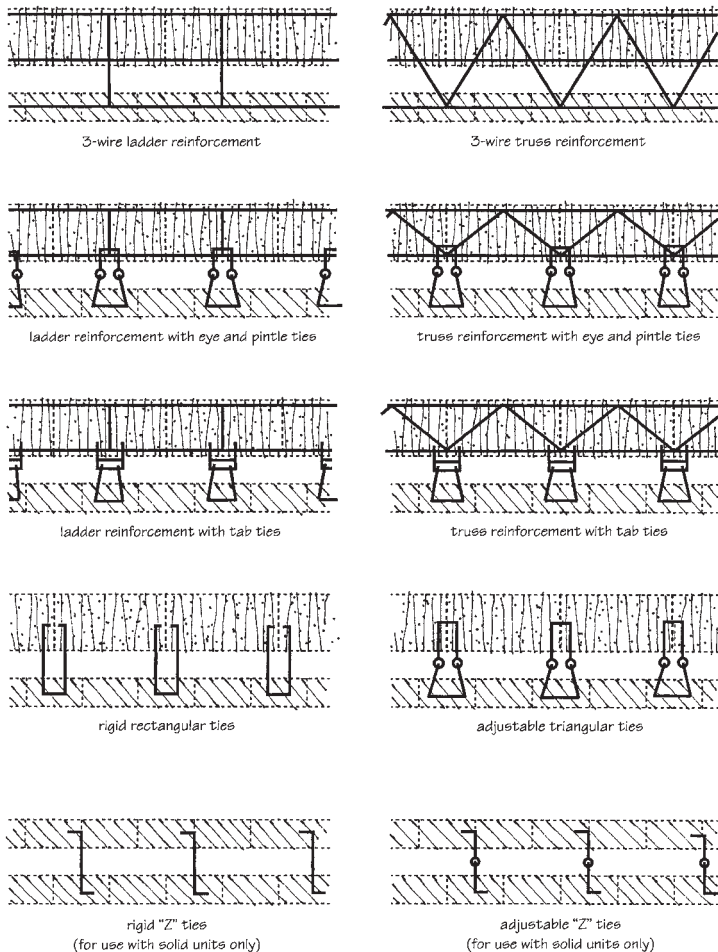


Figure 12-30 Metal ties and joint reinforcement for bonding multiwythe masonry walls. (From Beall and Jaffe, *Concrete and Masonry Databook*, McGraw-Hill, New York, 2003.)

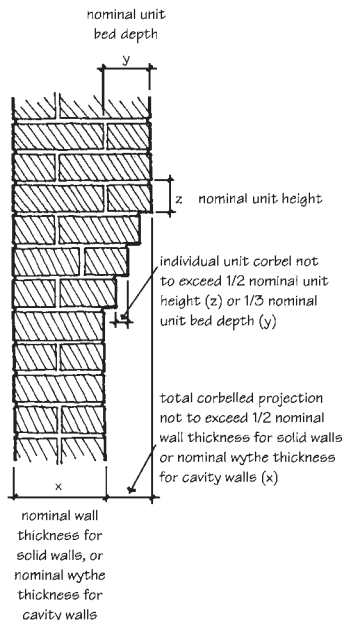


Figure 12-31 Empirical design limitations for corbelled masonry.

thermal and moisture movements. All critical loading conditions must be calculated. Fixity, or end restraint, must also be considered, as it affects resistance to applied loads.

Flexural, shear, and axial stresses resulting from wind or earthquake forces must be added to the stress of dead and live loads, and connections must be designed to resist such forces acting either inward or outward.

Strength design normally includes minimum and maximum reinforcement ratios, maximum allowable deflections under load, and ultimate moment capacity requirements. Even more important than the economy and efficiency which strength design provides by using masonry to its full structural capabilities is the fact that the performance of masonry is predicted more accurately than with the allowable stress method. Under severe earthquake loading, where wall response may be inelastic because of flexural yielding of the reinforcement under combined axial, bending, and shear loads, strength design provides greater safety because of its accuracy.

12.3.1 Masonry Compressive Strength

An engineer bases the design of masonry structural systems on a certain “specified compressive strength of masonry” (f'_m), on which the allowable axial, flexural, compressive, shear, and bearing stresses are based. Under IBC and MSJC Code requirements, the contractor must verify to the engineer by one of two methods that the proposed materials and construction will meet or exceed this strength. The contractor may elect to use the *unit strength method* based on the combined strength of the masonry units and mortar as determined by tables in the code, or the *prism test method*.

Projects that are not large enough to justify the cost of prism testing generally use the unit strength method. Through submittals, the contractor certifies that the proprietary masonry units specified in the contract documents or the generic masonry units selected to comply with specified ASTM standards are of sufficient strength to produce the “specified compressive strength” when combined with ASTM C476 grout and either the specified ASTM C270 mortar type (M, S, or N) or the ASTM C270 mortar type (M, S, or N) selected to produce the “specified compressive strength” (see Fig. 12-32). The proportion specification of ASTM C270 (the default) governs, as well as the proportion specification of ASTM C476. Both the proportion specifications of ASTM C270 and C476 and the unit strength method of determining “specified compressive strength” are very conservative and usually produce mortar and masonry of greater strength than the minimum required by the

The *unit strength method* of verifying specified compressive strength uses the tables below to show the net area compressive strength produced by combining units of a specific strength with Type M, S, or N mortar. The unit strength method of verifying f'_m may be used instead of laboratory prism testing when:

- units conform to ASTM requirements
- bed joint thickness does not exceed 5/8 in., and
- grout meets ASTM C476 requirements, or grout compressive strength is equal to f'_m but not less than 2000 psi

Required Net Area Compressive Strength of Clay Masonry Units (psi)		For Net Area Compressive Strength of Masonry (psi)	Required Net Area Compressive Strength of Concrete Masonry Units (psi)		For Net Area Compressive Strength of Masonry (psi)
When Used With Type M or S Mortar	When Used With Type N Mortar		When Used With Type M or S Mortar	When Used With Type N Mortar	
1,700	2,100	1,000	1,250	1,300	1,000
3,350	4,150	1,500	1,900	2,150	1,500
4,950	6,200	2,000	2,800	3,050	2,000
6,600	8,250	2,500	3,750	4,050	2,500
8,250	10,300	3,000	4,800	5,250	3,000
9,900	—	3,500			
13,200	—	4,000			

Figure 12-32 MSJC and International Building Code tables for unit strength method of verifying masonry compressive strength (f'_m). (From International Building Code 2003; and *Masonry Standards Joint Committee*, Specifications for Masonry Structures, ACI 530.1/ASCE 6/TMS 602-02)

design. This is a built-in high safety factor, but it does not produce the most cost-efficient design.

For large projects where efficiency in design can produce a cost savings by optimizing the use of materials in mortar and grout designs, the contractor may elect to use the prism test method to verify “specified compressive strength” (see Fig. 12-33). Using this method, the contractor hires a testing laboratory to produce mortar and grout mix designs in accordance with the minimum property specification of ASTM C476 and ASTM C270, respectively, which, when combined with the specified or selected masonry units, will produce the “specified compressive strength” when prisms are laboratory tested in accordance with ASTM C1314.

The process of verifying the compressive strength of masonry is similar to specifying concrete for small projects by stipulating a certain number of sacks of cement per cubic yard and a certain water-cement ratio (comparable to the unit strength method), and to specifying concrete for large projects by requiring a minimum compressive strength for which the contractor proposes a laboratory mix design (comparable to preconstruction prism testing) that is verified by cylinder tests of field-sampled concrete (comparable to field-constructed prism testing).

If the prism test method is used, ASTM C780 is used for preconstruction and construction evaluation of mortar mixes, ASTM C1019 is used for preconstruction and construction evaluation of grout mixes, and ASTM C1314 is used for prism tests (see Fig. 12-33). If the unit strength method is used, no testing is required.

12.3.2 Differential Movement

Buildings are dynamic structures whose successful performance depends on allowing the differential movement of adjoining or connecting elements to occur without excessive stress or its resulting damage. All building materials experience volumetric changes from temperature fluctuations, and some experience moisture-related movements as well. Structural movements include column shortening, elastic deformation, creep, and wind sway. The differential rates and directions of movements must be accommodated by flexible connections and movement joints (refer to Chapter 9).

Structural connections may be required to permit movement in some directions and transfer applied loads in others. For example, at the joint

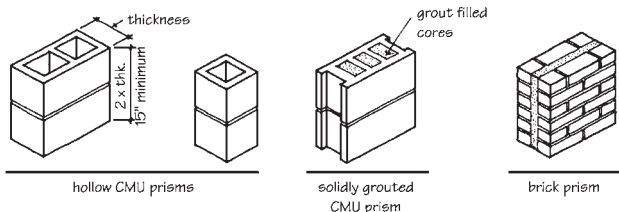


Figure 12-33 ASTM C1314 test prisms for masonry assemblies of units, mortar, and grout.

between interior bearing walls and exterior non-bearing wall shear flanges, the exterior wall will undergo more thermal movement and less elastic and creep-induced movement than the interior wall. The connection between these elements must accommodate such movement or transfer shear stress. Each building must be analyzed for differential movement characteristics and provisions made to relieve the resulting stresses. The MSJC Code is the first to include design coefficients for masonry thermal expansion, moisture expansion, shrinkage, and creep.

12.3.3 Unreinforced Masonry

Although the compressive strength of unreinforced masonry is high, its flexural strength depends on three things: (1) the type and design of the masonry unit, (2) the type of mortar and its materials, and (3) the quality of workmanship. Higher flexural strengths are developed with solid masonry units because the wider mortar bed provides more bonding surface. Failure in lateral loading usually results from bond failure at a ruptured bed joint, so factors that affect mortar bond also affect the flexural strength of the wall. Full, unfurrowed joints, good mortar flow and consistency, proper unit absorption, and moist curing all improve bond (see Chapter 15).

When lateral loads are applied perpendicular to a wall, they are transmitted to vertical and horizontal edge connections. The proportion of the load transmitted either vertically or horizontally will depend on the flexural resistance and rigidity of the wall in each direction, the degree of fixity or restraint developed at the edges, the horizontal-to-vertical span ratio, and the distribution of the loads as they are applied to the wall. The lateral stability of loadbearing masonry walls is greater than that of non-bearing or lightly loaded walls. Applied vertical loads produce compressive stresses which must be overcome by the tensile stress of the lateral load before failure can occur. In the lower stories of loadbearing buildings, compressive stresses generally counteract tension, but in the upper stories of tall buildings, where wind loads are higher and axial loads smaller, the allowable flexural tensile stresses may be exceeded, thus requiring steel reinforcement to be added at those locations.

12.3.4 Reinforced Masonry

Reinforced masonry is used where compressive, flexural, and shearing stresses are higher than those allowed for unreinforced masonry. Designs that incorporate reinforcing steel neglect the flexural strength contribution of the masonry altogether, and rely on the steel to resist 100% of the tensile loads. (This is called the cracked section theory).

Reinforced masonry walls may be of double-wythe construction with a grouted cavity to accommodate the steel reinforcing, or of single-wythe hollow units with grouted cores. Steel wire reinforcement may be laid in horizontal mortar joints as long as code requirements for wire size and minimum mortar cover are met. Vertical reinforcement must be held in position at the top and bottom of the bar as well as at regular vertical intervals.

Vertical reinforcing steel contributes to the load-carrying capacity of masonry columns and pilasters because lateral ties are required in columns to prevent buckling and confine the masonry within. The vertical steel in walls does not take any of the axial load unless it is also restrained against buckling. Reinforcing steel also helps masonry resist volume changes due to

temperature and moisture variations, and its effect should be considered in the calculation of differential movement and the location and spacing of movement joints.

The size and placement of steel reinforcement are determined by design analysis of service load conditions. Different combinations of bar sizes and spacing can give the same ratio of steel area to masonry area, and some consideration must be given to achieving the analytical requirements economically. Steel spaced too closely will slow construction, can inhibit grout placement, and may be unnecessarily expensive. For instance, No. 3 bars at 8 in. on center give the same area of steel per foot of wall as No. 7 bars at 48-in. centers, but the closer spacing requires more labor expense than is necessary to produce the same result. Bar size and spacing, however, must also take into consideration the size of the grout space and the code requirements for minimum protective coverage of reinforcement (see Chapters 6 and 15).

12.3.5 Wind and Seismic Loads

Buildings must be capable of resisting all lateral seismic forces, assumed to act nonconcurrently in the direction of each of the main axes of the structure. In addition to the calculation and resolution of total seismic forces, consideration must also be given to individual structural and non-structural elements of the building. Parts or portions of structures, non-structural components, and their anchorage to the main structural system must be designed for lateral seismic forces.

The MSJC Code includes requirements for structures in different Seismic Design Categories. Prescriptive requirements for minimum reinforcing steel are summarized in *Fig. 12-34*. The minimum amount of steel required is based on test results and empirical judgment rather than engineering analysis of stress or performance. The prescriptive ratio of steel to wall area is provided to increase the ductility of the masonry structure in seismic events. Where analytical design indicates that more steel is required, the prescriptive minimum may be included as part of the total. If analysis indicates that less steel is required, the prescriptive minimum seismic reinforcing must still be provided. Joint reinforcement cannot be used for seismic resistance. All reinforcing steel designed to resist seismic loads must be fully embedded in grouted cores, cavities, or bond beams. *Figures 12-35 and 12-36* illustrate the minimum reinforcing requirements of the code, and *Fig. 12-37* summarizes the requirements for shear walls.

Reinforced masonry structures designed in compliance with modern building code requirements have successfully withstood substantial seismic forces, and the rigidity inherent in the masonry systems often reduces or eliminates secondary damage. Reinforced masonry buildings as tall as 10 stories survived near the epicenter of the 7.1 Loma Prieta, California, earthquake in 1989 and the 6.7 Northridge, California, earthquake in 1994 without structural damage, glass breakage, pipe separations, or even cracking in the drywall or door jambs. Such secondary safety is critical in the construction of essential facilities such as hospitals, fire stations, communications centers, and other facilities required for emergency response. The only masonry buildings to sustain significant damage were older unreinforced masonry structures built before modern building code requirements and not yet retrofitted to meet stricter performance criteria. Older buildings which had been retrofitted in accordance with the City of Los Angeles Division 88 ordinance fared much better.

Seismic Design Category A or B

- No minimum reinforcing requirements. Walls must be anchored to walls, floors or roofs providing lateral support. For Seismic Category B, shear walls may not be empirically designed and must meet minimum requirements for "ordinary plain" shear walls.

Seismic Design Category C

- Comply with requirements for Categories A and B plus the following requirements.
- Masonry elements which are *not* part of the lateral-force-resisting system must be reinforced in *either* the vertical or horizontal direction, depending on location of the lateral supporting elements.
 - Horizontal joint reinforcement with two longitudinal 9 gauge (W1.7) wires spaced 16" on center maximum, or two #3 or one #4 bar spaced 48" on center maximum. Must include horizontal reinforcement within 16" of the top and bottom of wall.
 - Vertical reinforcement of two #3 or one #4 bar 48" on center maximum and within 16" of ends of walls.
- In addition to minimum reinforcing requirements, two #3 or one #4 bar on all sides of and adjacent to every opening larger than 16" in either direction, and extending 40 bar diameters or 24" minimum beyond the corners of the opening.
- For masonry elements which *are* part of the lateral-force-resisting system, shear walls must be reinforced in *both* the vertical and horizontal direction to comply with the minimum requirements for "ordinary reinforced" shear walls as follows:
 - Horizontal joint reinforcement with two longitudinal 9 gauge (W1.7) wires, spaced 16" on center, or two #3 or one #4 bar spaced not more than 10 ft. on center. Must include horizontal reinforcement at top and bottom of wall openings and extending 40 bar diameters or 24" minimum beyond the corners of the opening, within 16" of the tops of walls, and continuously at structurally connected roofs and floors.
 - Vertical reinforcement of two #3 or one #4 bar at corners, within 16" of each side of openings, within 8" of each side of movement joints, within 8" of ends of walls, and at 10 ft. on center maximum.

Seismic Design Category D

- Comply with requirements for Category C plus the following requirements.
- Masonry elements which *are* part of the lateral-force-resisting system must be reinforced in *both* the vertical and horizontal direction. The sum of the cross-sectional area of horizontal and vertical reinforcement must be at least 0.002 times the gross cross-sectional area of the wall, with 0.0007 minimum in each direction. Reinforcement must be evenly distributed. Maximum spacing of reinforcement is 48" for other than stack bond masonry. For stack bond masonry, units must be solid, solidly grouted hollow open-end units, or solidly grouted hollow units with full head joints, and reinforcement spaced a maximum of 24" on center.
- Shear walls must comply with the minimum requirements for "special reinforced" shear walls. Reinforcement spacing must be the smaller of one-third the height or length of the shear wall or 48" on center. Minimum cross-sectional area of vertical reinforcement must be one-third of the required shear wall reinforcement. Shear reinforcement must be anchored around vertical reinforcing bars with standard hook. Hooks for lateral tie anchorage shall be either 135° or 180° standard hooks. Columns must have lateral ties at 8" on center, minimum 3/8" diameter embedded in grout.

Seismic Design Category E or F

- Comply with requirements for Category D plus the following requirements.
- For stack bond walls which are *not* part of the lateral-force-resisting system, solid units or solidly grouted hollow open-end units, horizontal reinforcement with a cross-sectional area at least 0.0015 times the gross cross-sectional area of the masonry, maximum spacing 24" on center.
- For stack bond walls which *are* part of the lateral-force-resisting system, solid units or solidly grouted open-end units, horizontal reinforcement with a cross-sectional area at least 0.0025 times the gross cross-sectional area of the masonry, maximum spacing 16" on center.

Figure 12-34 Prescriptive masonry reinforcing requirements. (Based on MSJC, Building Code Requirements for Masonry Structures, ACI 530/ASCE 5/TMS 402-02)

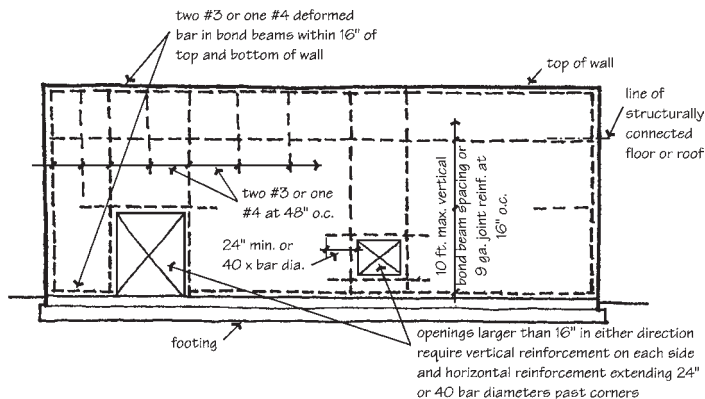
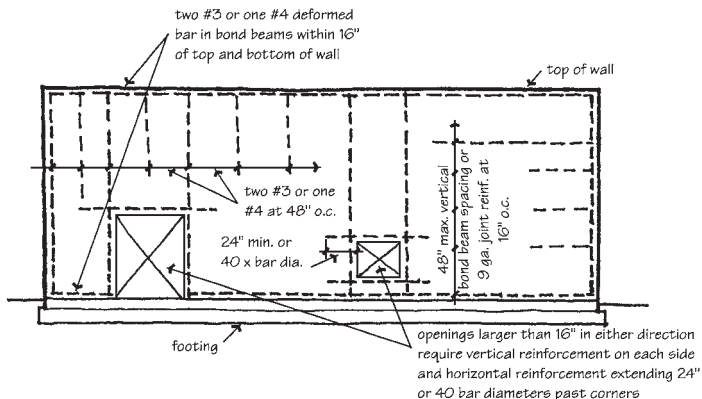
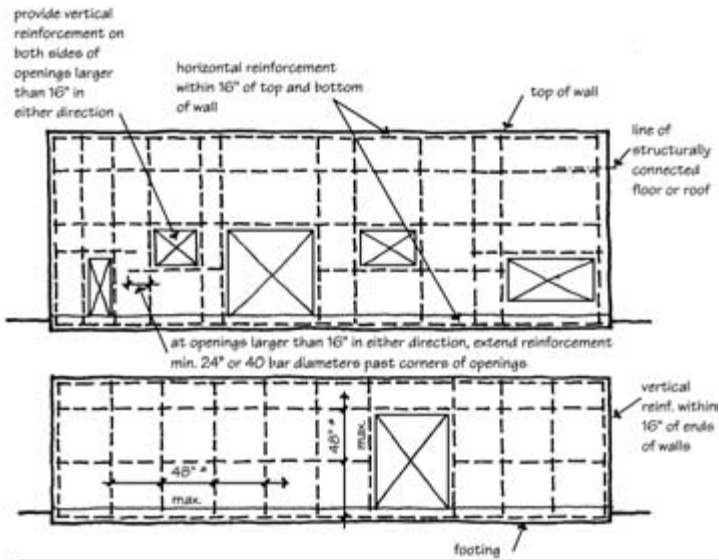


Figure 12-35 Minimum reinforcement required in Seismic Design Category C. (Based on MSJC Building Code Requirements for Masonry Structures, ACI 530/ASCE 5/TMS 402-02.)



- * Masonry elements that are part of the lateral-force-resisting system must have reinforcement in both the vertical and horizontal direction. The sum of the cross-sectional area of horizontal and vertical reinforcement must be 0.002 times the gross cross-sectional area of the wall, with 0.0007 minimum in each direction. Reinforcement must be evenly distributed and have a maximum spacing of the smaller of $1/3$ the wall height, $1/3$ the wall length, or $4'-0''$ on center. Requirements for stack bond masonry are more restrictive.

Figure 12-36 Minimum reinforcement required in Seismic Design Categories D, E, and F. (Based on MSJC, Building Code Requirements for Masonry Structures, ACI 530/ASCE 5/TMS 402-02.)

Type of Shear Wall	Design Method	Minimum Required Reinforcement	Permitted in Seismic Design Category
Empirical	Empirical Design	None	A
Ordinary Plain (unreinforced)	Allowable Stress Design, Strength Design, or Prestressed Masonry	None	A, B
Detailed Plain (unreinforced)	Allowable Stress Design or Strength Design	Vertical reinforcement of minimum one No. 4 or two No. 3 deformed steel bars area at corners, within 16" of each side of openings, within 8" of each side of movement joints, within 8" of the ends of walls, and at a maximum spacing of 10 ft. Horizontal reinforcement of either 2-wire, 9 gauge prefabricated joint reinforcement or minimum one No. 4 or two No. 3 deformed steel bond beam bars continuously at structurally connected roof and floor levels, within 16" of the top of walls, at the bottom and top of wall openings extending at least 24" or 40 bar diameters past the opening*, as well as 2-wire, 9 gauge prefabricated joint reinforcement spaced not more than 16" on center or minimum one No. 4 or two No. 3 deformed steel bond beam bars spaced 10 ft. on center.	A, B
Ordinary Reinforced	Allowable Stress Design or Strength Design	Vertical reinforcement of minimum one No. 4 or two No. 3 deformed steel bars at corners, within 16" of each side of openings, within 8" of each side of movement joints, within 8" of the ends of walls, and at a maximum spacing of 10 ft. Horizontal reinforcement of either 2-wire, 9 gauge prefabricated joint reinforcement or minimum one No. 4 or two No. 3 deformed steel bond beam bars continuously at structurally connected roof and floor levels, within 16" of the top of walls, at the bottom and top of wall openings extending at least 24" or 40 bar diameters past the opening*, as well as 2-wire 9 gauge prefabricated joint reinforcement spaced not more than 16" on center or minimum one No. 4 or two No. 3 deformed steel bond beam bars spaced 10 ft. on center.	A, B, C
Intermediate Reinforced	Allowable Stress Design or Strength Design	Vertical reinforcement of minimum one No. 4 or two No. 3 deformed steel bars at corners, within 16" of each side of openings, within 8" of each side of movement joints, within 8" of the ends of walls, and at a maximum spacing of 4 ft. Horizontal reinforcement of either 2-wire, 9 gauge prefabricated joint reinforcement or minimum one No. 4 or two No. 3 deformed steel bond beam bars continuously at structurally connected roof and floor levels, within 16" of the top of walls, at the bottom and top of wall openings extending at least 24" or 40 bar diameters past the opening*, as well as 2-wire 9 gauge prefabricated joint reinforcement spaced not more than 16" on center or minimum one No. 4 or two No. 3 deformed steel bond beam bars spaced 10 ft. on center.	A, B, C
Special Reinforced	Allowable Stress Design or Strength Design	Combined vertical and horizontal reinforcement at least 0.002 times gross cross-sectional area of wall, with a minimum of 0.0007 times gross cross-sectional area of wall in each direction, uniformly distributed and spaced at the smaller of 1/3 the length of the shear wall, 1/3 the height of the shear wall, or 4 ft. on center for masonry laid in other than stack bond. Shear reinforcement must be anchored around vertical reinforcing bars with a standard hook.	A, B, C, D, E, F

* Reinforcement adjacent to openings need not be provided for openings smaller than 16 in. in either the horizontal or vertical direction, unless the spacing of distributed reinforcement is interrupted by such reinforcement.

Figure 12-37 Masonry shear wall types. (Based on requirements of MSJC, Building Code Requirements for Masonry Structures, ACI 530/ASCE 5/TMS 402-02.)

13

FOUNDATION AND RETAINING WALLS

Masonry walls may be used to retain earth in landscape applications, below-grade building structures, and even swimming pools.

13.1 GENERAL CONSIDERATIONS Basement and retaining wall design must be concerned with allowable soil bearing pressures, lateral earth pressures, surcharge loads occurring during construction and in service, overturning moments, and sliding.

13.1.1 Soil Bearing Pressures

Building codes typically prescribe allowable soil bearing pressures for footing and foundation design according to the Unified Soil Classification System (see Fig. 13-1). *International Building Code* requirements for presumptive loadbearing values are shown in Fig. 13-2. Mud, organic silt, organic clay, peat, or unprepared fill must be sampled and tested to determine its bearing capacity, if any.

13.1.2 Lateral Earth Pressure

The magnitude and direction of soil pressure on the wall is dependent on the height and shape of the surface, and on the nature and physical properties of the backfill. The simplest way of determining lateral earth pressure is the *equivalent fluid method*. This method assumes that the retained earth will act as a fluid, and the wall is designed to withstand the pressure of a liquid assumed to exert the same pressure as the actual backfill material. Assumed equivalent-fluid unit weights vary with the nature of the soil in the backfill. Most building codes specify fluid pressures for various types of soil.

Properties of Soils Classified According to the Unified Soil Classification System					
Soil Group	Unified Soil Classification Symbol	Soil Description	Drainage Properties [‡]	Frost Heave Potential	Volume Change Potential Expansion [†]
Group I	GW	Well-graded gravels, gravel-sand mixtures, little or no fines	Good	Low	Low
	GP	Poorly graded gravels or gravel-sand mixtures, little or no fines	Good	Low	Low
	SW	Well-graded sands, gravelly sands, little or no fines	Good	Low	Low
	SP	Poorly graded sands or gravelly sands, little or no fines	Good	Low	Low
	GM SM	Silty gravels, gravel-sand-silt mixtures Silty sand, sand-silt mixtures	Good Good	Medium Medium	Low Low
Group II	GC	Clayey gravels, gravel-sand-clay mixtures	Medium	Medium	Low
	SC	Clayey sands, sand-clay mixtures	Medium	Medium	Low
	ML	Inorganic silts and very fine sands, rock flour, silty or clayey fine sands or clayey silts with slight plasticity	Medium	High	Low
	CL	Inorganic clays of low to medium plasticity, gravelly clays, sandy clays, silty clays, and lean clays	Medium	Medium	Medium to Low
Group III	CH	Inorganic clays of high plasticity	Poor	High	High
	MH	Inorganic silts, micaceous or diatomaceous fine sandy or silty soils, elastic silts	Poor	High	High
Group IV	OL	Organic silts and organic silty clays of low plasticity	Poor	Medium	Medium
	OH	Organic clays of medium to high plasticity, and organic silts	Unsatisfactory	Medium	High
	Pt	Peat and other highly organic soils	Unsatisfactory	Medium	High

[‡] The percolation rate for good drainage is over 4 in. per hour. Medium drainage is 2-4 in. per hour. Poor drainage is less than 2 in. per hour.

[†] Soils with a low potential expansion have a plasticity index (PI) of 0 to 15. Soils with a medium potential expansion have a PI of 10 to 35. Soils with a high potential expansion have a PI greater than 20.

Figure 13-1 Soil classification typically used in building codes.

Allowable Footing and Foundation Pressures				
Class of Material	Allowable Bearing Pressure (psf)	Lateral Bearing (psf per foot below natural grade)	Lateral Sliding	
			Coefficient of Friction [‡]	Resistance (psf) [†]
Crystalline bedrock	12,000	1200	0.70	—
Sedimentary rock	4,000	400	0.35	—
Sandy gravel and/or gravel (GW and GP)	3,000	200	0.35	—
Sand, silty sand, clayey sand, silty gravel, and clayey gravel (SW, SP, SM, SC, GM and GC)	2,000	150	0.25	—
Clay, sandy clay, silty clay, clayey silt and sandy silt (CL, ML, MH and CH)	1,500	100	—	130

[‡] Coefficient to be multiplied by the dead load.

[†] Lateral sliding resistance value to be multiplied by the contact area.

Figure 13-2 Allowable soil pressures. (From International Building Code 2003.)

13.1.3 Frost Depth

The water in soil freezes and expands, then contracts again when it thaws. This phenomenon is called *frost heave*. Footings and foundations must be set below the winter frost line to avoid damage from frost heave. The depth to which the soil freezes depends not only on climate and geographic location, but also on soil composition, altitude, and weather patterns. The maps in *Fig. 13-3* show average depth and average maximum depth of frost penetration.

13.1.4 Surcharge

Additional loads are created by operating automobiles, trucks, or construction equipment on the soil surface behind a retaining wall or basement wall. If activities of this nature are anticipated, the design must make allowance for the increased lateral pressures that will be imposed on the wall.

13.1.5 Overturning and Sliding

Retaining walls must safely resist overturning and sliding forces induced by the retained earth. Unless otherwise required by code, the factor of safety against overturning should not be less than 2.0, and against sliding 1.5. In addition, the bearing pressure under the footing should not exceed the allowable soil bearing pressure. In the absence of controlled tests substantiating the actual bearing capacity of the soil, building codes list allowable pressures for different types of soil. Local requirements may vary slightly and should be checked to assure design conformance.

13.1.6 Expansion and Control Joints

The size and location of expansion or control joints should be calculated on the basis of expected movement. Joints should always be provided at wall offsets and at abrupt changes in height or thickness. Joints should be designed with a shear key for lateral stability, but still allow for longitudinal movement (refer to Chapter 9). Weep-hole openings should be protected at the back to prevent clogging with backfill material.

13.1.7 Materials

Brick masonry for earth retaining structures should be ASTM C62, ASTM C216, or ASTM C652, Grade SW, with a minimum strength of 5000 psi. Hollow concrete units should be ASTM C90 normal weight, with an oven-dry density of 125 lb/cu ft or more. Special interlocking concrete segmental retaining wall block should meet the requirements of ASTM C1372. Mortar should comply with the requirements of ASTM C270, Type M, and grout with ASTM C476. Mortar and grout should be moist-cured for 7 days before backfilling. Concrete for footings should have a minimum compressive strength of 2000 psi, or as required by structural analysis.

13.2 FOUNDATION WALLS

For both residential and commercial buildings, it is often economical to use masonry walls to enclose basements, crawl spaces, or underground parking

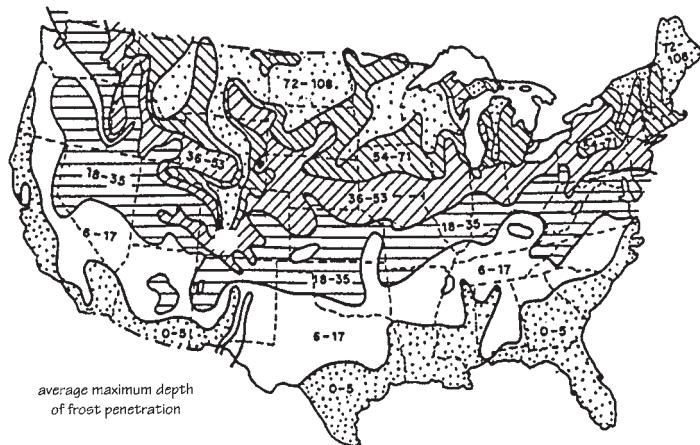
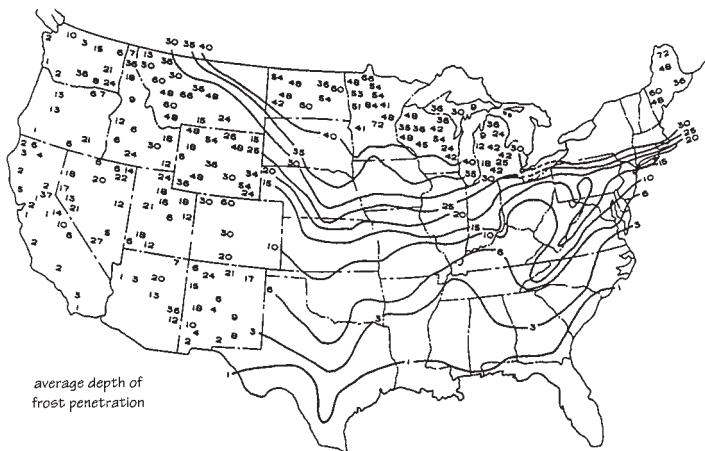


Figure 13-3 Frost depth averages in the continental United States. (From U.S. Weather Bureau.)

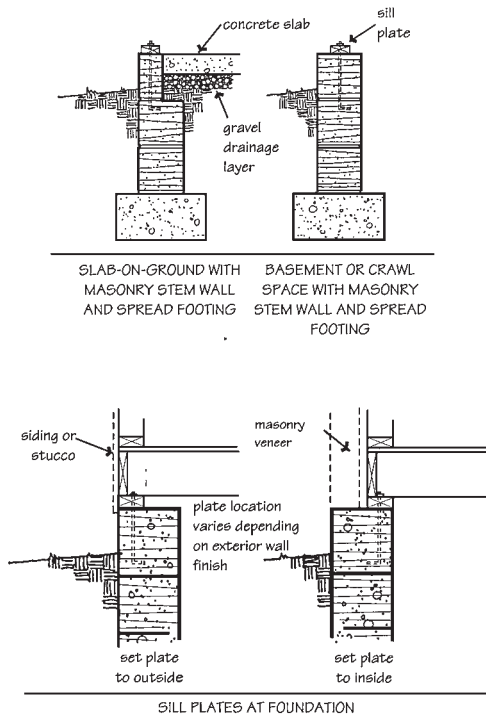


Figure 13-4 Concrete masonry foundation types and sill plate details.

areas. *Figure 13-4* shows basic concrete masonry foundation types. Footings are set below the frost line in undisturbed soil. The masonry walls provide low thermal conductivity and may easily be waterproofed against moisture infiltration and dampness. Below-grade masonry walls also offer excellent enclosures for underground or earth-sheltered buildings. Analytically designed reinforced masonry permits the construction of deep basement walls, walls supporting heavy vertical loads, and walls where unsupported height or length exceeds lateral support requirements for empirically designed, unreinforced masonry.

13.2.1 Design and Construction

Concrete masonry is much more widely used in below-grade construction than brick, and much research has been done to test its capability and performance. General design considerations must include (1) maximum lateral load from soil pressure, (2) vertical loads from building superstructure, (3) minimum wall thickness required by code, and (4) length or height of wall between lateral supports. Basement walls supporting bearing wall construction must usually support relatively heavy compressive loads in addition to earth pressure or other lateral loads. In skeleton frame construction, columns may extend down to separate footings and carry most of the dead and live loads of the superstructure. In such cases, the basement walls may be subject to appreciable lateral load, but little vertical load. If the columns are closely spaced, or if pilasters are added, the wall may be designed to transmit these lateral loads horizontally and vertically as two-way slabs. If the vertical supports are widely spaced, and the first-floor construction cannot be considered as providing lateral support, a design cantilever action will be required (i.e., retaining wall design).

It is normally assumed that the stresses created in basement walls by soil pressure against the exterior face are resisted by bending of the walls in the vertical span. This means that the wall behaves like a simple beam supported at top and bottom. Support at the top is provided by the first-floor construction, and bottom support by the footing and basement floor slab. If the first floor is to contribute lateral support, backfilling should be delayed until this construction is in place.

A portion of the lateral earth load is carried by the wall acting as a beam in the horizontal span. The distribution of the total lateral load horizontally and vertically will depend on wall height and length as well as stiffness in both directions. If the length of the wall between supports is no greater than its height, the load is generally divided equally between vertical and horizontal spans.

The overall stability of a below-grade wall may be enhanced by increasing the stiffness in either direction, or by reducing the length of the horizontal span. *Horizontal stiffness* can be increased by incorporating bond beams into the design, or by placing prefabricated joint reinforcement in the mortar joints at vertical intervals of not more than 16 in. Bond beams are most advantageously located at or near the top of the wall, and built to extend continuously around the perimeter of the building. When used in this manner, they will also serve to distribute concentrated vertical loads. The increase in flexural strength achieved with horizontal joint reinforcement is limited by the practical amount of steel that can be embedded in the joints, and by the amount of bond strength developed between mortar, reinforcement, and masonry units.

Vertical stiffness may be increased in one of two ways: (1) steel reinforcement may be grouted into hollow cells, or (2) pilasters may be added (see Fig. 13-5). Pilasters should project from the wall a distance equal to approximately one-twelfth of the wall height. Pilaster width should be equal to approximately one-tenth of the horizontal span between supports. The distance between pilasters or between end walls or cross walls and pilasters should not exceed 18 ft for unreinforced walls 10 in. thick, or 15 ft for walls 8 in. thick.

In relying on floors and footings for lateral bracing, proper anchorage of members must be provided to assure transfer of loads. Steel dowels should connect walls securely to the footing. Pilasters, cross walls, and end walls must be bonded with interlocking masonry units or with metal ties. Sill plates should be anchored to the wall at 6-ft maximum intervals (see Fig. 13-6).

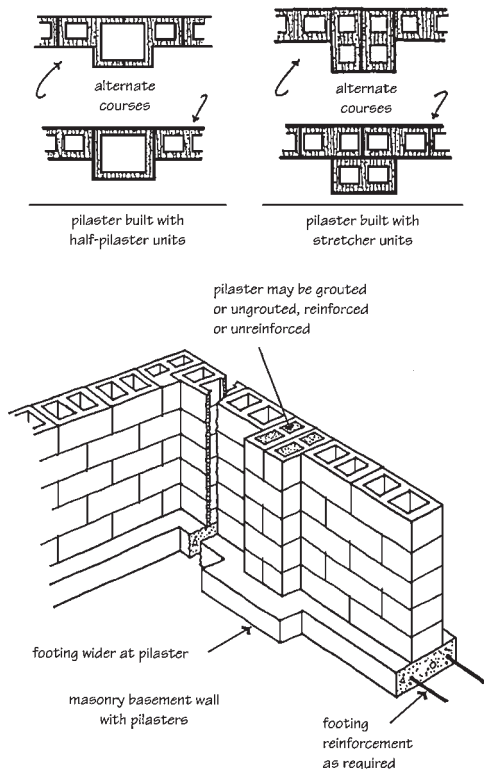


Figure 13-5 Concrete masonry basement wall with pilasters. (From NCMA TEK Bulletin 1.)

Intersecting walls should be anchored with $24 \times \frac{1}{4} \times 1\frac{1}{2}$ -in. metal straps spaced not more than 32 in. on center vertically. If a partition does not provide lateral support, strips of metal lath, galvanized hardware cloth, or joint reinforcement may be substituted for the heavier straps.

Mortar joints at the intersection of cross walls with exterior below-grade walls should be raked out and caulked to form a control joint. Sill plates should be connected with $\frac{1}{2}$ -in.-diameter bolts extended at least 15 in. into the filled cells of the masonry, and spaced to within 12 in. of the end of the plate.

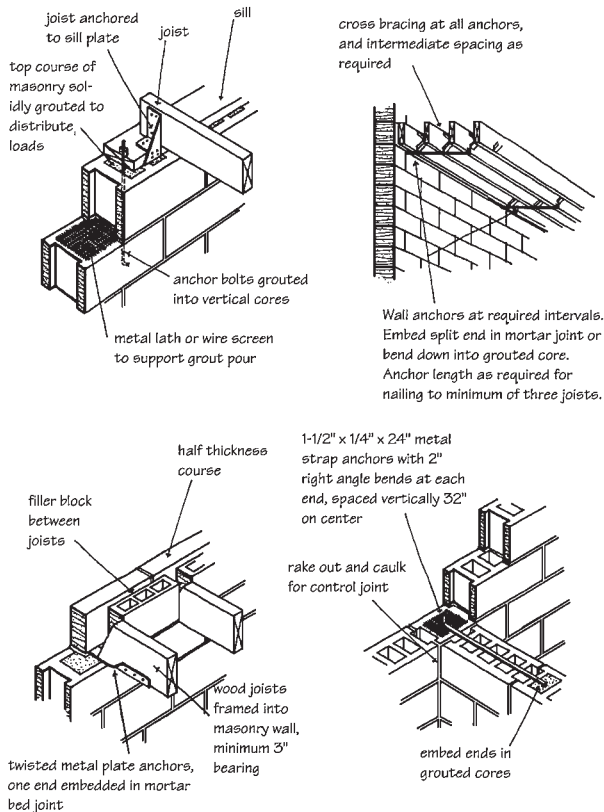


Figure 13-6 Foundation wall anchorage details. (From NCMA TEK Bulletin 1.)

Where beams bear on a basement wall, at least two block cores in the top course below the end of the member should be filled with mortar or grout, or a bearing plate installed to distribute loads. Pilasters may be bonded to the wall at beam locations to provide additional support, and should be grouted solid in the top course. Ends of floor joists should be anchored at 6-ft intervals (normally every fourth joist). At least the first three joists running parallel to a wall should also be anchored to it at intervals not exceeding 8 ft.

The axial load on basement walls is usually transmitted eccentrically at some point between the centerline of the wall and the inner surface, thus inducing a bending moment. Additional moment is induced at any point where flexural members are restrained by their connection to the wall. These moments tend to counteract the bending moments from lateral earth pressures at the exterior face. In other words, vertical compressive loads are effective in reducing the tensile stresses developed in resisting lateral loads. In this regard, it is important to remember that only dead loads may be safely considered as opposing lateral bending stresses, since live loads may be intermittent. Precautions must also be taken in construction scheduling to ensure that the amount of dead load calculated for such resistance is actually present before the lateral load is applied. If early backfill is unavoidable, temporary bracing must be provided to prevent actual stresses from exceeding those assumed in the design.

Other loads applied to below-grade walls may be variable, transient, or moving, such as surcharge, wind, snow, earthquake, or impact forces. The pressures from wind that ordinarily affect basement and foundation walls are those transmitted indirectly through the superstructure: compressive, uplift, shearing, or racking loads. Stresses developed in resisting overturning are not often critical except for lightweight structures subject to high wind loads, or for structures having a high ratio of exposed area to depth in the direction of wind flow. Analytical design procedures may be used to analyze and calculate such forces so that the masonry structure will adequately resist all applied loads and induced stresses.

13.2.2 Unreinforced Walls

Unreinforced masonry basement walls may be designed by the empirical or analytical procedures described in Chapter 12. Empirical requirements in some codes include only minimum wall thickness, height limitations, and height- or length-to-thickness ratios which dictate column or pilaster spacing (see Fig. 13-7). In the *International Residential Code*, minimum wall thickness and unbalanced fill height are also tied to soil type (see Fig. 13-8). Using analytical design, exact load determinations will dictate spacing of pilasters or placement of reinforcing at critical locations. Compressive and flexural strength, slenderness coefficients, and eccentricity ratios are all considered in the analysis, and the wall is designed for safety and efficiency.

13.2.3 Reinforced Walls

If unreinforced masonry walls are not adequate to resist the anticipated service loads, reinforced walls can be designed to accommodate higher compressive and flexural stresses. Reinforced walls are analytically designed so that the steel reinforcement resists flexural stresses higher than those permitted for unreinforced walls. A detailed structural analysis will determine exact requirements and criteria for reinforcement. For residential foundations, the *International Residential Code* provides tables of minimum reinforcing requirements which may be used in lieu of engineering analysis for 8-in., 10-in., and 12-in.-thick walls (see Figs. 13-9 through 13-11).

13.2.4 Footings

Some general rules of thumb may be applied to the preliminary design of footings for below-grade masonry walls: (1) cast-in-place concrete should have a

MSJC Code Requirements for Minimum Masonry Foundation Wall Thickness for Empirically Designed Masonry		
Foundation Wall Construction	Min. Nominal Thickness (in.)	Maximum Depth of Unbalanced Backfill (ft.)
UngROUTED hollow masonry units	8	5
	10	6
	12	7
Solid masonry units	8	5
	10	7
	12	7
Hollow or solid masonry units fully grouted	8	7
	10	8
	12	8

MSJC Code Empirical Span-to-Thickness Ratios for Lateral Support of Masonry Foundation Walls	
Wall or Element	Maximum Unsupported Height or Length to Nominal Thickness (l/t or h/t)
Bearing walls solid or grouted solid all other walls	20
	18
	18
Non-bearing walls, exterior	18

Figure 13-7 MSJC empirical design requirements for masonry foundation walls. (From *MSJC Building Code Requirements for Masonry Structures, ACI 530/ASCE 5/TMS 402.*)

minimum compressive strength of 2500 psi, (2) footing depth should be equal to the wall thickness and footing width equal to twice the wall thickness (see Fig. 13-12), and (3) the bottom of the footing should be placed in undisturbed soil below the frost line. For residential construction, the *International Residential Code* prescribes minimum dimensions (see Fig. 13-12). Allowable soil bearing pressure, of course, must be checked against actual loads in the final design.

13.2.5 Drainage and Waterproofing

Proper drainage and waterproofing of below-grade walls is essential, not only to prevent build-up of hydrostatic pressure, but also to maintain dry conditions and eliminate dampness in interior spaces. *Figures 13-13 and 13-14* show some typical methods of waterproofing masonry basement walls.

Damp or wet conditions in basements can be caused by vapor diffusion through the walls or by condensation of moist air inside the space. Condensation will occur anytime the surface temperature of the wall is below the dew-point temperature of the interior air. Condensation can usually be controlled by increasing ventilation or by the proper location and installation of vapor retarders and wall insulation (see Chapters 8 and 19). *Figure 13-15* shows how soil moisture vapor can be blocked out using materials with low vapor permeance on the outside of the walls and below the basement slab.

Requirements for Unreinforced Masonry Foundation Walls				
Maximum Wall Height (ft.)	Max. Unbalanced Backfill Height ³ (ft.)	Plain Masonry ⁴ Minimum Nominal Wall Thickness (in.)		
		Soil Classes ²		
		GW, GP, SW and SP	GM, GC, SM, SM-SC and ML	SC, MH, ML-CL and Inorganic CL
5	4	6 solid ⁴ or 8	6 solid ⁴ or 8	6 solid ⁴ or 8
	5	6 solid ⁴ or 8		
6	4	6 solid ⁴ or 8	6 solid ⁴ or 8	6 solid ⁴ or 8
	5	6 solid ⁴ or 8	8	10
	6	8	10	12
7	4	6 solid ⁴ or 8	8	8
	5	6 solid ⁴ or 8	10	10
	6	10	12	10 solid ⁴
	7	12	10 solid ⁴	12 solid ⁴
8	4	6 solid ⁴ or 8	6 solid ⁴ or 8	8
	5	6 solid ⁴ or 8	10	12
	6	10	12	12 solid ⁴
	7	12	12 solid ⁴	Note 6
	8	10 solid ⁴	12 solid ⁴	Note 6
9	4	6 solid ⁴ or 8	6 solid ⁴ or 8	8
	5	8	10	12
	6	10	12	12 solid ⁴
	7	12	12 solid ⁴	
	8	12 solid ⁴	Note 5	Note 5
	9	Note 5	Note 5	Note 5

- Notes: 1. Mortar shall be Type M or Type S and masonry shall be laid in running bond. UngROUTED hollow masonry units are permitted except where otherwise indicated.
2. Soil classes are in accordance with Unified Soil Classification System.
3. Unbalanced backfill height is the difference in height of the exterior and interior finish ground levels. Where an interior concrete slab is provided, the unbalanced backfill height shall be measured from the exterior finish ground level to the top of the interior concrete slab.
4. Solid grouted hollow units or solid masonry units (i.e. having core area less than 25%).
5. Wall construction shall be reinforced as required for Reinforced Masonry Foundation Walls.

Figure 13-8 Requirements for unreinforced masonry foundation walls. (*From International Residential Code for One- and Two-Family Dwellings, 2003.*)

13.3 RETAINING WALLS

Because retaining walls are often used in landscape applications and may not enclose habitable space, attention to design and detailing is often cursory. However, the walls are exposed to extremes of weather, are in contact with earth, are often saturated with moisture, and must resist significant lateral forces. Such severity of use and exposure demands careful attention to design and details.

13.3.1 Traditional Retaining Wall Types

There are four basic types of traditional masonry retaining walls (*see Fig. 13-16*). Reinforced cantilever walls offer the most economical design, and are most commonly used. The vertical stem is reinforced to resist tensile stress-

Minimum Vertical Reinforcement Size and Spacing ^{1,2} for 8-in. Nominal Masonry ³ Foundation Wall Thickness				
Maximum Wall Height (ft.)	Maximum Unbalanced Backfill Height ⁵ (ft.)	Soil Classes ⁴		
		GW, GP, SW, and SP	GM, GC, SM, SM-SC, and ML	SC, MH, ML-CL, and Inorganic CL
6	5	#4 @ 48" o.c.	#4 @ 48" o.c.	#4 @ 48" o.c.
	6	#4 @ 48" o.c.	#4 @ 40" o.c.	#5 @ 48" o.c.
7	4	#4 @ 48" o.c.	#4 @ 48" o.c.	#4 @ 48" o.c.
	5	#4 @ 48" o.c.	#4 @ 48" o.c.	#4 @ 40" o.c.
	6	#4 @ 48" o.c.	#5 @ 48" o.c.	#5 @ 40" o.c.
	7	#4 @ 40" o.c.	#5 @ 40" o.c.	#6 @ 48" o.c.
8	5	#4 @ 48" o.c.	#4 @ 48" o.c.	#4 @ 40" o.c.
	6	#4 @ 48" o.c.	#5 @ 48" o.c.	#5 @ 40" o.c.
	7	#5 @ 48" o.c.	#6 @ 48" o.c.	#6 @ 40" o.c.
	8	#5 @ 40" o.c.	#6 @ 40" o.c.	#6 @ 24" o.c.
9	5	#4 @ 48" o.c.	#4 @ 48" o.c.	#5 @ 48" o.c.
	6	#4 @ 48" o.c.	#5 @ 48" o.c.	#6 @ 48" o.c.
	7	#5 @ 48" o.c.	#6 @ 48" o.c.	#6 @ 32" o.c.
	8	#5 @ 40" o.c.	#6 @ 32" o.c.	#6 @ 24" o.c.
	9	#6 @ 40" o.c.	#6 @ 24" o.c.	#6 @ 16" o.c.

- Notes: 1. Alternative reinforcing bar sizes and spacings having an equivalent cross-sectional area of reinforcement per lineal foot of wall are permitted provided the spacing of the reinforcement does not exceed 72 in.
2. Vertical reinforcement must be Grade 60 minimum. The distance from the face of the soil side of the wall to the center of the vertical reinforcement must be at least 5 in.
3. Mortar shall be Type M or Type S and masonry shall be laid in running bond.
4. Soil classes are in accordance with Unified Soil Classification System.
5. Unbalanced backfill height is the difference in height of the exterior and interior finish ground levels. Where an interior concrete slab is provided, the unbalanced backfill height shall be measured from the exterior finish ground level to the top of the interior concrete slab.

Figure 13-9 Requirements for 8-in.-thick masonry foundation walls. (From International Residential Code for One- and Two-Family Dwellings, 2003.)

es. The concrete footing anchors the stem and resists overturning and sliding due to both vertical and lateral forces. Proprietary systems of interlocking concrete masonry units also offer economical and attractive solutions for unreinforced retaining wall applications of moderate height.

Some of the primary considerations in retaining wall design should be:

- A proper cap or coping to prevent water collecting or standing on top of the wall
- A waterproof coating on the back of the wall to prevent saturating the masonry
- Permeable backfill behind the wall to collect water and prevent soil saturation and increased hydrostatic pressure
- Weep holes or drain lines to drain moisture
- Expansion or control joints to permit longitudinal thermal and moisture movement

Minimum Vertical Reinforcement Size and Spacing ^{1,2} for 10-in. Nominal Masonry ³ Foundation Wall Thickness				
Maximum Wall Height (ft.)	Maximum Unbalanced Backfill Height ⁵ (ft.)	Soil Classes ⁴		
		GW, GP, SW, and SP	GM, GC, SM, SM-SC, and ML	SC, MH, ML-CL, and Inorganic CL
7	4	#4 @ 56" o.c.	#4 @ 56" o.c.	#4 @ 56" o.c.
	5	#4 @ 56" o.c.	#4 @ 56" o.c.	#4 @ 56" o.c.
	6	#4 @ 56" o.c.	#4 @ 48" o.c.	#4 @ 40" o.c.
	7	#4 @ 56" o.c.	#5 @ 56" o.c.	#5 @ 40" o.c.
8	5	#4 @ 56" o.c.	#4 @ 56" o.c.	#4 @ 48" o.c.
	6	#4 @ 56" o.c.	#4 @ 48" o.c.	#5 @ 56" o.c.
	7	#4 @ 48" o.c.	#4 @ 32" o.c.	#6 @ 56" o.c.
	8	#5 @ 56" o.c.	#5 @ 40" o.c.	#7 @ 56" o.c.
9	5	#4 @ 56" o.c.	#4 @ 56" o.c.	#4 @ 48" o.c.
	6	#4 @ 56" o.c.	#4 @ 40" o.c.	#4 @ 32" o.c.
	7	#4 @ 56" o.c.	#5 @ 48" o.c.	#6 @ 48" o.c.
	8	#4 @ 32" o.c.	#6 @ 48" o.c.	#4 @ 16" o.c.
	9	#5 @ 40" o.c.	#6 @ 40" o.c.	#7 @ 40" o.c.

- Notes: 1. Alternative reinforcing bar sizes and spacings having an equivalent cross-sectional area of reinforcement per lineal foot of wall are permitted provided the spacing of the reinforcement does not exceed 72 in.
2. Vertical reinforcement must be Grade 60 minimum. The distance from the face of the soil side of the wall to the center of the vertical reinforcement must be at least 6.75 in.
3. Mortar shall be Type M or Type S and masonry shall be laid in running bond.
4. Soil classes are in accordance with Unified Soil Classification System.
5. Unbalanced backfill height is the difference in height of the exterior and interior finish ground levels. Where an interior concrete slab is provided, the unbalanced backfill height shall be measured from the exterior finish ground level to the top of the interior concrete slab.

Figure 13-10 Requirements for 10-in.-thick masonry foundation walls.
(From International Residential Code for One- and Two-Family Dwellings, 2003.)

13.3.2 Cantilever Walls

Reinforced concrete masonry unit (CMU) cantilever retaining walls are designed to resist overturning and sliding with resultant forces that fall within the middle third of the footing. Many design tables have been developed to simplify selection of wall dimensions and steel reinforcing in CMU retaining walls. The table and drawings in *Fig. 13-17*, from the Portland Cement Association, are typical. Graphic examples of design parameters for 4- to 10-ft-high walls are given in Newman's *Standard Structural Details for Building Construction*.

Figure 13-18 shows three different methods of locating vertical reinforcement in a brick masonry cantilever retaining wall. Each offers certain advantages depending on wall thickness, bar spacing, and unit type. Where 8-in. hollow units are available (B), they can often be less expensive than a doublewythe wall. If only standard units are available, grout pockets may be used (A). A double-wythe grouted cavity wall, however, offers greatest flexibility because bar spacing is not limited by the fixed dimensions of the units (C).

The table in *Fig. 13-19* was developed by the Brick Industry Association (BIA) for preliminary design of brick walls with a maximum height of 6 ft.

Minimum Vertical Reinforcement Size and Spacing ^{1,2} for 12-in. Nominal Masonry ³ Foundation Wall Thickness				
Maximum Wall Height (ft.)	Maximum Unbalanced Backfill Height ⁵ (ft.)	Soil Classes ⁴		
		GW, GP, SW, and SP	GM, GC, SM, SM-SC, and ML	SC, MH, ML-CL, and Inorganic CL
7	4	#4 @ 72" o.c.	#4 @ 72" o.c.	#4 @ 72" o.c.
	5	#4 @ 72" o.c.	#4 @ 72" o.c.	#4 @ 72" o.c.
	6	#4 @ 72" o.c.	#4 @ 64" o.c.	#4 @ 48" o.c.
	7	#4 @ 72" o.c.	#4 @ 48" o.c.	#5 @ 56" o.c.
8	5	#4 @ 72" o.c.	#4 @ 72" o.c.	#4 @ 72" o.c.
	6	#4 @ 72" o.c.	#4 @ 56" o.c.	#5 @ 72" o.c.
	7	#4 @ 64" o.c.	#5 @ 64" o.c.	#4 @ 32" o.c.
	8	#4 @ 48" o.c.	#4 @ 32" o.c.	#5 @ 40" o.c.
9	5	#4 @ 72" o.c.	#4 @ 72" o.c.	#4 @ 72" o.c.
	6	#4 @ 72" o.c.	#4 @ 56" o.c.	#5 @ 64" o.c.
	7	#4 @ 56" o.c.	#4 @ 40" o.c.	#6 @ 64" o.c.
	8	#5 @ 64" o.c.	#6 @ 64" o.c.	#6 @ 48" o.c.
	9	#5 @ 56" o.c.	#7 @ 72" o.c.	#6 @ 40" o.c.

- Notes: 1. Alternative reinforcing bar sizes and spacings having an equivalent cross-sectional area of reinforcement per lineal foot of wall are permitted provided the spacing of the reinforcement does not exceed 72 in.
2. Vertical reinforcement must be Grade 60 minimum. The distance from the face of the soil side of the wall to the center of the vertical reinforcement must be at least 8.75 in.
3. Mortar shall be Type M or Type S and masonry shall be laid in running bond.
4. Soil classes are in accordance with Unified Soil Classification System.
5. Unbalanced backfill height is the difference in height of the exterior and interior finish ground levels. Where an interior concrete slab is provided, the unbalanced backfill height shall be measured from the exterior finish ground level to the top of the interior concrete slab.

Figure 13-11 Requirements for 12-in.-thick masonry foundation walls.
(From International Residential Code for One- and Two-Family Dwellings, 2003.)

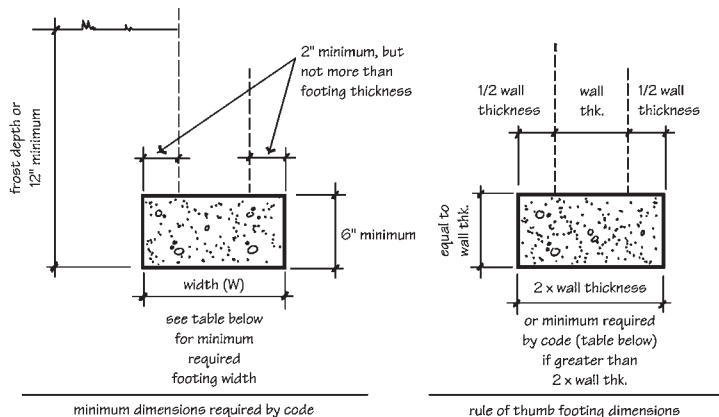
The bottom of the footing must be below the frost line. Units should be Grade SW, and mortar should be type M. All brick retaining walls should be laid in running bond pattern with masonry headers or metal ties every sixth course.

13.3.3 Footings

Concrete footings for retaining walls should be placed on firm, undisturbed soil. In areas subject to freezing, they should also be placed below the frost line to avoid heave and possible damage to the wall. If the soil under the footing consists of soft or silty clay, it may be necessary to place compacted fill before pouring the concrete.

13.3.4 Drainage and Waterproofing

Failure to drain the backfill area behind retaining walls causes a buildup of hydrostatic pressure which can quickly become critical if rainfall is heavy. In mild climates, weep holes at the base of the wall should be provided at 4- to 8-ft intervals. In areas where precipitation is heavy or where poor drainage



Minimum Width (W) of Concrete Footings (in.) ⁵				
Load Bearing Value of Soil (psf) →	1,500	2,000	3,000	≥4,000
4-in. Brick Veneer Over Light Frame or 8-in. Hollow Concrete Masonry				
1 story	12	12	12	12
2 story	21	16	12	12
3 story	31	24	16	12
8-in. Solid or Fully Grouted Masonry				
1 story	16	12	12	12
2 story	29	21	14	12
3 story	42	32	21	16

⁵ Where minimum footing width is 12 in., a single wythe of solid or fully grouted 12-in. nominal concrete masonry units is permitted in lieu of concrete footing.

(From International Residential Code for One- and Two-Family Dwellings, 2003.)

Figure 13-12 Rule-of-thumb and code-required minimum concrete footing dimensions.

conditions exist, prolonged seepage through weep holes can cause the soil in front of the wall and under the toe of the footing to become saturated and lose some of its bearing capacity. In these instances, a continuous longitudinal drain of perforated pipe should be placed near the base with discharge areas located beyond the ends of the wall (see Fig. 13-20).

BIA recommends that backfill against brick retaining walls from the top of the footing to within 12 in. of finished grade should be coarse gravel, 2 ft wide, and run the entire length of the wall. To prevent the infiltration of

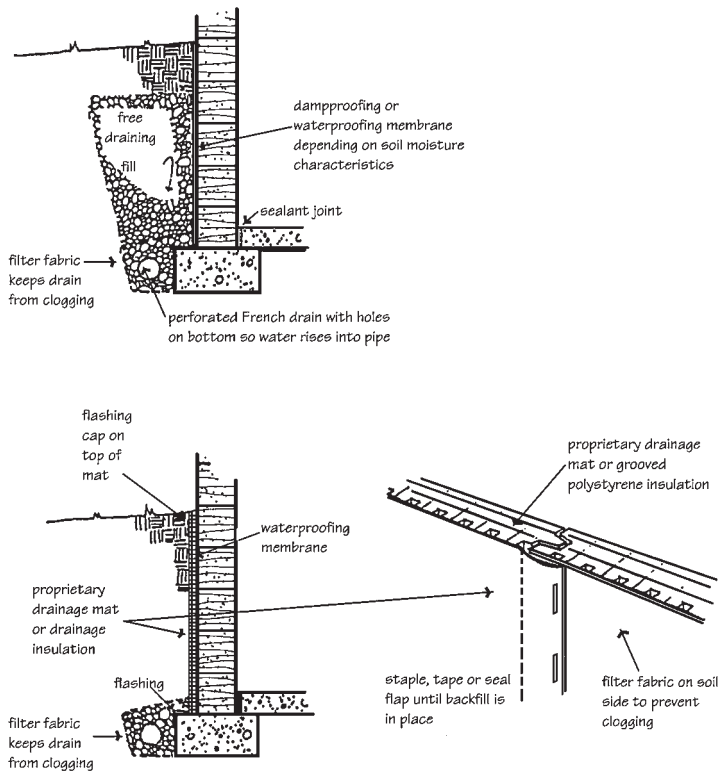


Figure 13-13 Basic waterproofing for masonry basement walls.

fine fill material or top soil, a layer of 50-lb filter fabric is laid along the top of this course. Weep holes or drain lines at the bottom of the wall to relieve moisture buildup in the gravel fill should extend the full length of the wall.

Waterproofing requirements for the back face of a retaining wall will depend on the climate, soil conditions, and type of masonry units used. Seepage through a brick wall can cause efflorescence if soluble salts are present, but a waterproof membrane will prevent this water movement. Walls of porous concrete units should always receive waterproof backing because of the excessive expansion and contraction that accompanies variable moisture

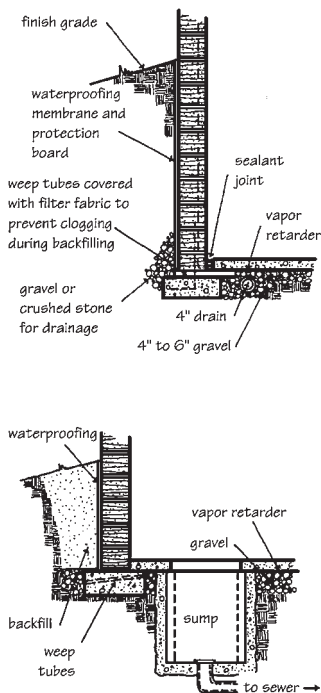
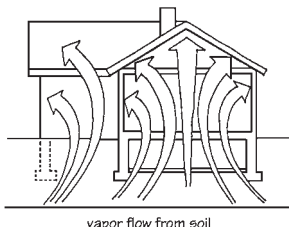


Figure 13-14 Alternative waterproofing and drainage strategies for masonry basement walls. (From NCMA TEK Bulletin 1.)

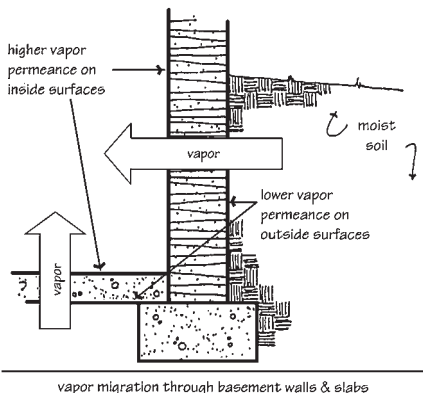
content. In climates subject to freezing, a waterproof membrane can prevent the potentially destructive action of freeze-thaw cycles when moisture is present in the units.

13.3.5 Segmental Retaining Walls

One of the newest developments in the concrete masonry industry is the dry-stacked, interlocking concrete block retaining wall. Sometimes referred to as segmental retaining walls (SRWs), a variety of proprietary units and systems are available (refer to Chapter 4). The units are stepped back



(From W.R. Meadows, Inc., *The Hydrologic Cycle and Moisture Migration*)



(From Beall, *Thermal and Moisture Protection Manual*, McGraw-Hill, 1999)

Figure 13-15 Soil moisture vapor.

slightly in each course, or battered, toward the embankment. Some units interlock simply by their shape, while others use pins or dowels to connect successive courses. Because they are dry-stacked without mortar, interlocking retaining wall systems are simple and fast to install. The open joints allow free drainage of soil moisture, and the stepped-back designs reduce overturning stresses.

The National Concrete Masonry Association has published the *Design Manual for Segmental Retaining Walls*, which presents a thorough engineering methodology, guide specifications, test methods, and design tables for two types of retaining walls. *Conventional SRWs* are structures that resist external destabilizing forces from the retained soils solely through self-

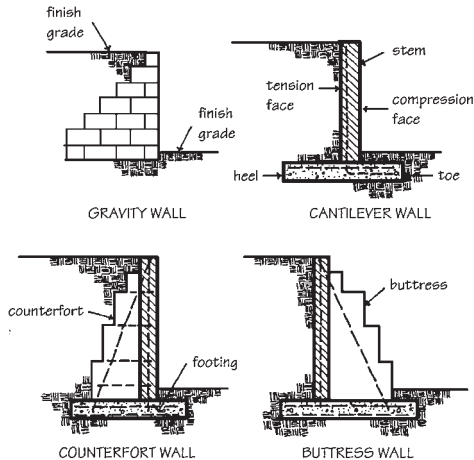
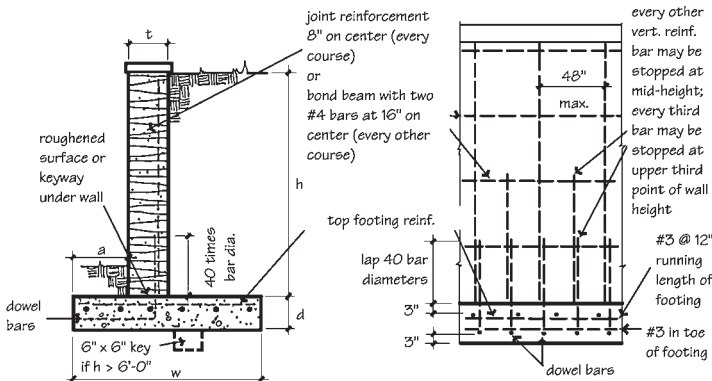


Figure 13-16 Four types of retaining walls. (From NCMA TEK Bulletin 4A.)

weight and batter of the SRW units (see Fig. 13-21). Conventional SRWs may be either single or multiple unit depths. *Soil-reinforced SRWs* are composite systems consisting of SRW units in combination with a mass of retained soil stabilized by horizontal layers of geosynthetic reinforcement materials (see Fig. 13-22). Some systems can be laid in either straight or curved lines, but others are limited to straight lines and 90° corners. No mortar is required for SRW systems, but the units must be restrained against sliding by either a physical interlocking shape or shear connectors such as rods, pins, or clips (see Fig. 13-23).

Because they are dry-stacked, segmental retaining walls are relatively flexible, and can tolerate movement and settlement without distress. Typically supported on flexible aggregate leveling-bed foundations, SRWs also permit water to drain directly through the face of the wall, so hydrostatic pressure is eliminated and weep holes are not necessary. Drainage through the face of the wall, however, can cause staining, efflorescence, and possible freeze-thaw damage if the units remain saturated from wet soil. Primary drainage is provided by gravel backfill and, in very wet areas, collection pipes at the base of the wall. The maximum height that can be constructed with a single-unit-depth conventional SRW is directly proportional to its weight, width, and vertical batter for any given soil type and site geometry conditions (see Fig. 13-24). The height can be increased by using multiple unit depths. Soil-reinforced SRWs use geosynthetic reinforcement to enlarge the effective width and weight of the gravity mass. The reinforce-



Dimensions and Reinforcement for CMU Cantilever Retaining Wall*

Nominal Wall Thickness, t (in.)	Wall Stem Height, h (ft.-in.)	Toe Length, a (in.)	Footing Width, w (ft.-in.)	Footing Depth, d (in.)	Dowels and Vertical Reinforcement	Top Footing Reinforcement
8	3'-4"	12	2'-8"	9	#3 @ 32" o.c.	#3 @ 27" o.c.
	4'-0"	12	3'-0"	9	#4 @ 32" o.c.	#3 @ 27" o.c.
	4'-8"	12	3'-3"	10	#5 @ 32" o.c.	#3 @ 27" o.c.
	5'-4"	14	3'-8"	10	#4 @ 16" o.c.	#4 @ 27" o.c.
	6'-0"	15	4'-2"	12	#6 @ 24" o.c.	#4 @ 27" o.c.
12	3'-4"	12	2'-8"	9	#3 @ 32" o.c.	#3 @ 27" o.c.
	4'-0"	12	3'-0"	9	#3 @ 32" o.c.	#3 @ 27" o.c.
	4'-8"	12	3'-3"	10	#4 @ 32" o.c.	#3 @ 27" o.c.
	5'-4"	14	3'-8"	10	#4 @ 24" o.c.	#3 @ 25" o.c.
	6'-0"	15	4'-2"	12	#4 @ 16" o.c.	#4 @ 30" o.c.
	6'-8"	16	4'-6"	12	#6 @ 24" o.c.	#4 @ 22" o.c.
	7'-4"	18	4'-10"	12	#7 @ 32" o.c.	#5 @ 26" o.c.
	8'-0"	20	5'-4"	12	#7 @ 24" o.c.	#5 @ 21" o.c.
	8'-8"	22	5'-10"	14	#7 @ 16" o.c.	#6 @ 26" o.c.
9'-4"	24	6'-4"	14	#8 @ 8" o.c.	#6 @ 21" o.c.	

* Design based on zero slope soil backfill weighing 100 pcf with an equivalent fluid pressure of 45 pcf and a soil bearing pressure 1,500 psf, with no surcharge load. Reinforcing steel is deformed bars with a yield strength of 40,000 psi.

Figure 13-17 Concrete masonry retaining walls. (Adapted from Randall and Panarese, Concrete Masonry Handbook, Portland Cement Association.)

ment (either geogrids or geotextiles) extends through the interface between the SRW units and into the soil to create a composite gravity mass structure. This composite structure offers increased resistance for taller walls, surcharged structures, or more difficult soil conditions. As an alternative to a single high wall in steeply sloped areas, two shorter walls can be stepped against the slope (see Fig. 13-25).

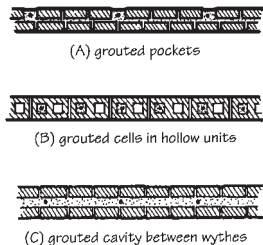
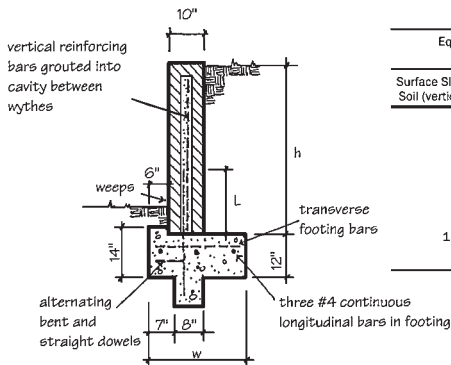


Figure 13-18 Three methods of placing reinforcing steel in brick retaining walls. (From BIA Technical Note 17N.)

Both conventional and soil-reinforced SRWs function as gravity retaining walls. To be stable, a gravity retaining wall must have sufficient weight (mass) and width to resist both sliding at the base and overturning of the mass about the toe of the structure. Stability calculations that involve forces acting on the boundary of the gravity structure are called external stability calculations. For soil-reinforced SRWs and multiple-depth conventional SRWs, a set of internal stability calculations are also required to ensure that there is adequate strength and width to create the stable monolithic gravity mass. The local stability of the dry-stacked column of units must also be analyzed. The NCMA *Design Manual for Segmental Retaining Walls* provides complete engineering calculations, soil information, test methods, guide specifications, and design tables.

Segmental retaining walls are typically installed in a shallow trench with a sand leveling bed and gravel backfill (see Fig. 13-26). In poorly drained soils, a 4- to 6-in. gravel or crushed stone drainage bed should be installed in a slightly deeper trench, then a layer of filter fabric before the sand leveling bed is placed. Getting the base course of units level is critical to the strength and stability of the wall. The gravel backfill should be added in lifts as the wall is built.



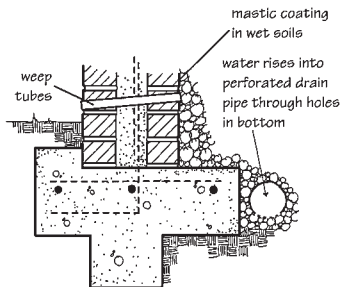
Equivalent Fluid Pressure for Retained Slopes	
Surface Slope of Retained Soil (vertical : horizontal)	Equivalent Fluid Pressure (pcf)
Level	30
1 : 5	32
1 : 4	35
1 : 3	38
1 : 2	43
1 : 1-1/2	55
1 : 1	80

Dimensions and Reinforcement for Double-Wythe Brick Retaining Walls*

Wall Stem Height, h (ft.-in.)	Footing Width, w (ft.-in.)	Reinforcing Dowels	Length of Dowel Lap, L (ft.-in.)	Vertical Reinforcement	Transverse Footing Reinforcement
2'-0"	1'-9"	#3 @ 40" o.c.	1'-10"	—	#3 @ 40" o.c.
2'-6"	1'-9"	#3 @ 40" o.c.	2'-4"	—	#3 @ 40" o.c.
3'-0"	2'-0"	#3 @ 40" o.c.	2'-10"	—	#3 @ 40" o.c.
3'-6"	2'-0"	#3 @ 40" o.c.	3'-4"	—	#3 @ 40" o.c.
4'-0"	2'-4"	#3 @ 27" o.c. or #4 @ 40" o.c.	1'-4"	#3 @ 27" o.c. or #3 @ 40" o.c.	#3 @ 27" o.c. or #3 @ 40" o.c.
4'-6"	2'-8"	#3 @ 19" o.c. or #4 @ 35" o.c.	1'-6"	#3 @ 38" o.c. or #3 @ 35" o.c.	#3 @ 19" o.c. or #3 @ 35" o.c.
5'-0"	3'-0"	#3 @ 14" o.c. or #4 @ 25" o.c. or #5 @ 40" o.c.	1'-8"	#3 @ 28" o.c. #3 @ 25" o.c. #4 @ 40" o.c.	#3 @ 14" o.c. #3 @ 25" o.c. #4 @ 40" o.c.
5'-6"	3'-3"	#3 @ 1" o.c. or #4 @ 20" o.c. or #5 @ 31" o.c.	1'-10"	#3 @ 22" o.c. or #4 @ 40" o.c. or #4 @ 31" o.c.	#3 @ 11" o.c. or #3 @ 20" o.c. or #4 @ 31" o.c.
6'-0"	3'-6"	#3 @ 8" o.c. or #4 @ 14" o.c. or #5 @ 20" o.c.	2'-0"	#3 @ 16" o.c. or #4 @ 28" o.c. or #5 @ 40" o.c.	#3 @ 8" o.c. or #3 @ 14" o.c. or #4 @ 20" o.c.

* Design based on zero slope soil backfill with equivalent fluid pressure of 30 psf, with no surcharge load. Masonry is fully grouted, and reinforcing steel has a yield strength of 40,000 psi.

Figure 13-19 Double-wythe brick retaining walls. (Adapted from BIA Technical Note 17N.)



WEEP TUBES AND PERFORATED DRAIN

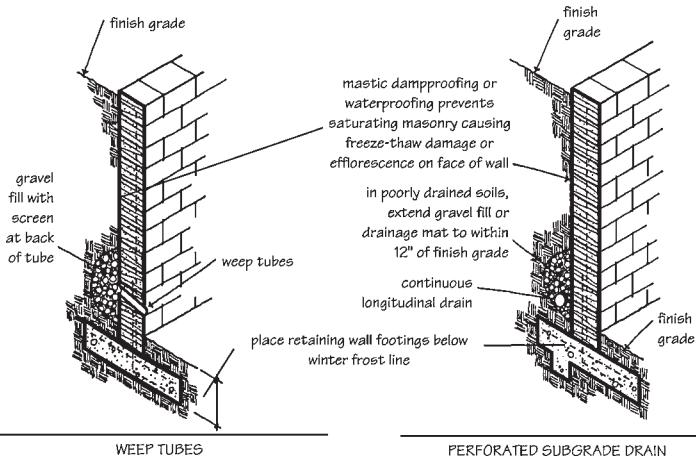


Figure 13-20 Retaining wall drainage and weeps.

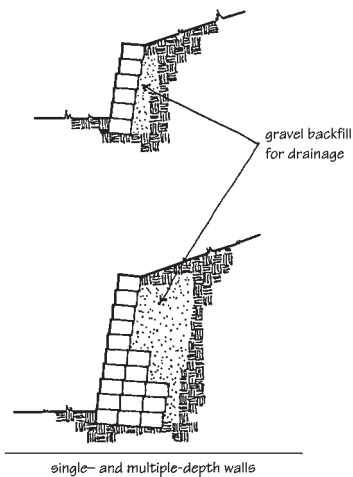


Figure 13-21 Conventional segmental retaining walls. (From *NCMA Design Manual for Segmental Retaining Walls, 1993.*)

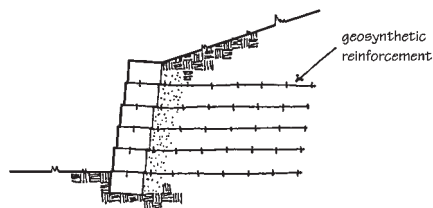


Figure 13-22 Soil-reinforced segmental retaining walls. (From *NCMA Design Manual for Segmental Retaining Walls, 1993.*)

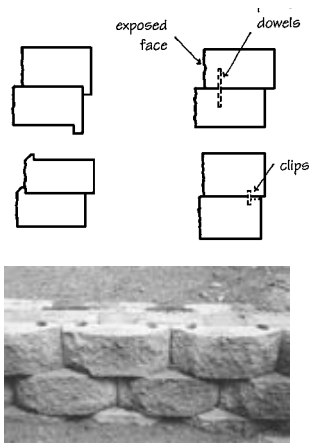


Figure 13-23 Units interlock physically or mechanically to resist sliding.

		Maximum Exposed Wall Height*					
		Angle of Internal Friction of Soil, ϕ (See Table Below)					
		$\phi = 28^\circ$			$\phi = 34^\circ$		
Segmental Unit Height (in.)	Segmental Unit Depth (in.)	Wall Battered 5°	Wall Battered 10°	Wall Battered 15°	Wall Battered 5°	Wall Battered 10°	Wall Battered 15°
6	12	2'-0"	2'-6"	3'-0"	2'-6"	3'-6"	3'-6"
	24	5'-0"	5'-6"	6'-0"	6'-6"	7'-6"	7'-6"
8	12	2'-3"	2'-3"	2'-10"	2'-10"	3'-6"	3'-6"
	24	4'-10"	5'-6"	6'-3"	6'-3"	7'-6"	7'-6"

* Design based on non-critical case walls without soil reinforcing, zero slope backfill at top of wall, no surcharge load, required 6 in. wall embedment. In ground at toe, soil and block unit weight 120 pcf.

Angle of Internal Friction (ϕ) for Various Soil Types		Angle of Internal Friction (Degrees)
GW	Well-graded gravels, gravel-sand mixtures, little or no fines	37 to 42
GP	Poorly graded gravels or gravel-sand mixtures, little or no fines	
SW	Well-graded sands, gravelly sands, little or no fines	33 to 40
SP	Poorly graded sands or gravelly sands, little or no fines	
GM	Silty gravels, gravel-sand-silt mixtures	28 to 35
SM	Silty sand, sand-silt mixtures	
GC	Clayey gravels, gravel-sand-clay mixtures	
SC	Clayey sands, sand-clay mixtures	
ML	Inorganic silts and very fine sands, rock flour, silty or clayey fine sands or clayey silts with slight plasticity	25 to 32
CL	Inorganic clays of low to medium plasticity, gravelly clays, sandy clays, silty clays, and lean clays	

Figure 13-24 Maximum height of segmental retaining walls. (From NCMA Design Manual for Segmental Retaining Walls, 1993.)

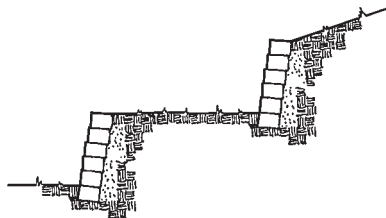


Figure 13-25 Two-level terraced wall.

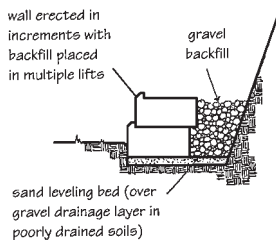


Figure 13-26 Segmental retaining wall construction.

14

MASONRY PAVING AND FIREPLACES

Two of the most common non-structural masonry applications are paving and fireplaces. Masonry's non-combustibility and heat storage capacity have always made it the material of choice for functional fireplaces, and its aesthetic warmth is symbolic even in purely decorative non-functional hearths.

Roads made of stone paving blocks were built by the Romans over 2000 years ago, some of which are still in use today. Many cities in the United States and Europe also have brick streets that continue in service after many years of heavy use, and have proved both durable and easy to maintain. After World War II, economical methods of manufacturing high-strength concrete paving units were developed. Since their introduction, concrete pavers have been used extensively in Europe and increasingly in the United States and Canada.

14.1 MASONRY PAVING

Clay, concrete, and stone paving units may all be used for interior or exterior applications, and may be installed over different sub-bases suitable for residential and commercial buildings, walkways, patios, streets, and parking areas. Paving assemblies are classified in accordance with the type of base used and the rigidity or flexibility of the paving itself. *Rigid paving* is defined as units laid in a bed of mortar and with mortar joints between the units. *Flexible paving* contains no mortar below or between the units.

Base supports may be rigid, semirigid, flexible, or suspended. A *rigid base diaphragm* is a reinforced concrete slab on grade, and can accommodate either rigid or flexible paving. A *semirigid continuous base* usually consists of asphalt or other bituminous road pavement, and is suitable for flexible paving. A *flexible base* is compacted gravel or a damp, loose, sand-cement mixture that is tamped in place. Only flexible paving should be laid over this type of base. *Suspended diaphragm* bases are structural floor or roof deck assemblies, the composition of which will vary depending on the type of structural system used. Either flexible or rigid paving may be used on suspended decks.

Selection of the type of paving system to be used will depend to a large extent on the desired aesthetic effect and the intended use. There are a number of design considerations that must be taken into account, particularly for outdoor paving. Heavy vehicular traffic generally requires rigid concrete diaphragms or semirigid asphalt bases. Lighter vehicular and pedestrian traffic may be supported on flexible bases and flexible paving. Traffic patterns, which dictate the size and shape of a paved area, may also influence the choice of base and cushion material. Successful installations always depend on proper subgrade preparation and removal of all vegetation and organic materials from the area to be paved. Soft spots of poor soil should be removed and filled with suitable material, then properly compacted.

Site preparation and system selection should also take into consideration the location of underground utilities and storm drainage systems. With rigid concrete bases and rigid masonry paving, access must be provided by means of manholes, cleanout plugs, and so on. If semirigid or flexible bases are used with flexible paving, however, the user may gain unlimited access to underground pipes and cables without incurring the expense of extensive surface repairs. This fact is generally cited as one of the major advantages of flexible masonry paving, which allows utility repairs and alterations by simply removing, stockpiling, and then replacing the paving units and base material. No air hammers or concrete pours are required to complete the work, and there is reduced danger of damage to utilities by the elimination of such equipment.

14.1.1 Outdoor Paving

Drainage is very important in the consideration of all outdoor paving systems, and excessive runoff is a legitimate environmental concern. In addition to mortarless paving systems, which permit a degree of water percolation through the joints, masonry paving units have been developed that lessen the impact of storm drainage even further. These concrete masonry grid pavers contain open spaces designed for growth of indigenous grasses to maintain soil permeability while providing a stable base for vehicular traffic. Grid units have also been used in a variety of applications for soil stabilization, erosion control, and aesthetic treatment of drainage and access. Installations include shoulder slopes along highways and under bridges, the lining of canals, construction of mobile home parks, boat launch ramps, fire lanes adjacent to apartments and hotels, and erosion control of steep embankments (see Fig. 14-1).

14.1.2 Bases

The successful performance of masonry paving systems depends to a great extent on proper base preparation for the type of pedestrian or vehicular traffic anticipated. Flexible paving is installed without mortar over sand, gravel, or asphalt bases (see Fig. 14-2). Rigid paving is installed with a mortar setting bed over a concrete base, and has mortar in the head joints between units (see Fig. 14-3).

Gravel bases provide maximum drainage efficiency and prevent the upward flow of moisture by capillary action. Clean, washed gravel should be specified. Bases of unwashed gravel mixed with fine clay and stone dust are popular low-cost systems, but they will cause a loss of porosity and effective drainage due to hardening with the absorption of moisture. Masonry units in

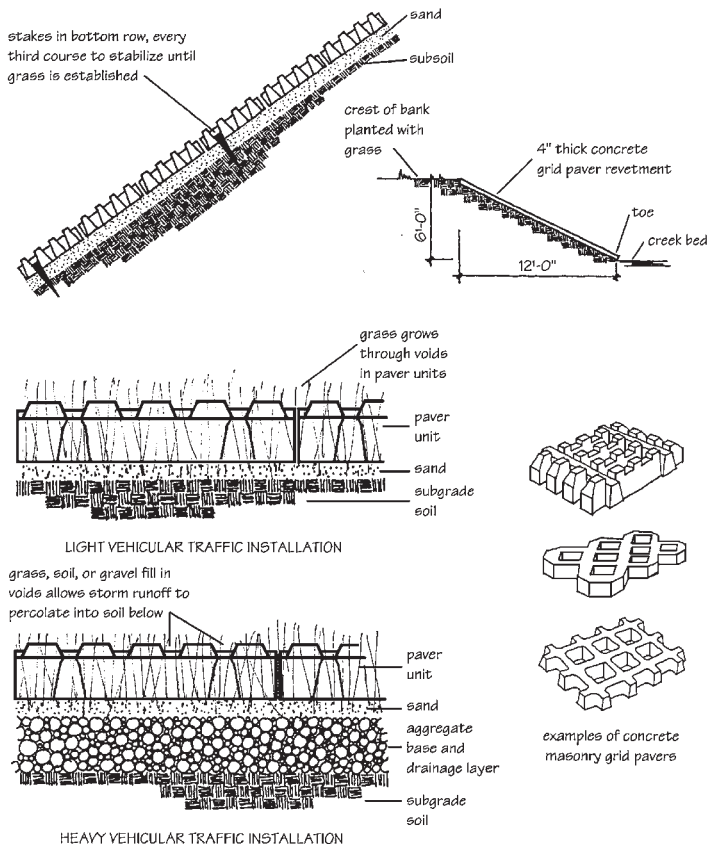


Figure 14-1 Concrete masonry grid paver installations. (From NCMA TEK Bulletin 91.)

direct contact with such contaminated materials may also be susceptible to efflorescence as a result of soluble salts leached to the surface (see Chapter 16). Gravel bases are suitable only for flexible paving, but can accommodate both pedestrian and light vehicular traffic. Ungraded gravel bases have better interlocking qualities, where graded gravel has a tendency to roll underfoot. Stone screenings compact better than pea gravel, but provide poorer subsur-

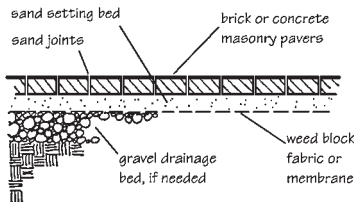


Figure 14-2 Flexible masonry paving. (From Beall, *Masonry and Concrete for Residential Construction*, McGraw-Hill Complete Construction Series, 2001.)

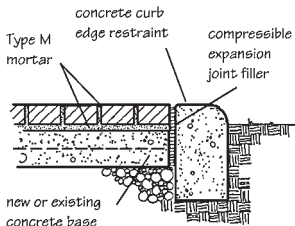


Figure 14-3 Rigid masonry paving. (From Beall, *Masonry and Concrete for Residential Construction*, McGraw-Hill Complete Construction Series, 2001.)

face drainage. Large gravel generally requires the use of heavy road construction equipment for proper preparation, whereas stone screenings of fine gradation lend themselves to compaction with hand tools. If the paving units are turned on edge for greater compressive depth, thin bases of fine screenings can accommodate the same light vehicular loads as thicker beds of coarse gravel. Aggregate bases range in thickness from 3 to 12 in., depending on the expected load and the paver thickness (see Fig. 14-4). Paving for vehicular traffic should be engineered for anticipated loads and the base material, thickness, compaction and optimum moisture content designed specifically for each site.

Concrete bases with either flexible or rigid paving can support heavy vehicular traffic. Existing concrete surfaces may be used, but major cracks must be properly filled and stabilized. If a mortar leveling bed is used over new or existing slabs, the surface should be raked or floated to facilitate good bond. If a non-cementitious leveling bed or cushion is used, the surface of new concrete need only be screeded.

Asphalt bases (new or used) can support flexible paving systems for heavy vehicular traffic. Mortar leveling beds can be used, but there will be little or no bond between the mortar and the asphalt. Mortar leveling beds should not be placed on hot or warm asphalt or flash setting of the mortar will occur. Any major defects in an existing asphalt pavement should be repaired before installing masonry pavers.

Concrete Masonry Paving Base and Paver Thickness			
Application	Aggregate Sub-Base Thickness (in.)		Thickness of Concrete Masonry Paving Units (in.)
	Well-Drained, Dry Areas	Low, Wet Areas	
Light duty Residential driveways, patios, pool decks, walkways, parking, bicycle paths, erosion control, temporary paving	0–3	4–8	2-1/2–3
Medium duty Sidewalks, shopping malls, residential streets, public parking, bus stops, service roads, cross walks, parking lots, camping areas, mobile home parks, canal lining, safety zones, maintenance areas, farm equipment storage	4–6	10	3–4
Heavy duty City streets, intersections, gas stations, loading docks, loading ramps, industrial floors, stables	8	12	4–6

Note: The sand bed between the sub-base and the concrete pavers is always 2 in. thick.

Figure 14-4 General recommendations for base and paver thickness for concrete masonry pavers. (From NCMA TEK Bulletin 75.)

14.1.3 Setting Beds

Mortar setting beds may be used for rigid paving over concrete bases. A Type M portland cement-lime mortar is generally recommended for outdoor use in horizontal applications. Thickness of the bed may vary from $\frac{1}{2}$ to 1 in. Bituminous setting beds composed of aggregate and asphaltic cement may be used over concrete or bituminous bases for flexible paving installations. The mix is generally designed and prepared at an asphalt plant and delivered to the job site ready for application.

Cushion material is generally placed between mortarless pavers and the base as a leveling layer that compensates for minor irregularities of the surface or the units. Sand for this purpose should be specified in accordance with ASTM C144. Under extremely wet conditions, however, sand cushions will provide poor drainage. Sand cushions over gravel bases require a membrane to prevent settlement. Dry mixtures of 1 part portland cement and 3 to 6 parts damp, loose sand may also be used. The higher sand ratio mixtures will provide little or no bond between paver and cushion. Roofing felt (15- to 30-lb weight) provides some compensation for minor irregularities, can be installed rapidly, and adds a degree of resilience for pavers installed over concrete bases. Felt or special weed block fabric will also prevent the growth of grass or weeds in the joints of flexible pavements.

To prevent horizontal movement of mortarless paving, a method of containment must be provided around the perimeter of the paved areas. A soldier course, railroad ties, metal edging, or concrete curbs will all provide the required stability (see Fig. 14-5). Any new edging that must be installed should be placed prior to the paving units, and the pavers worked toward the established perimeters. Modular planning in the location of perimeter edging can eliminate or reduce the amount of cutting required to fit the units.

14.1.4 Paving Joints

Installing masonry paving with mortar joints may be done in one of three ways:

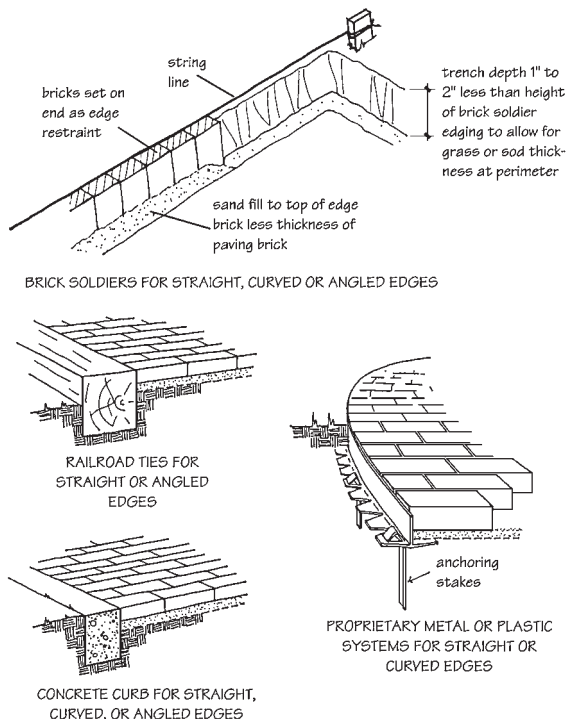


Figure 14-5 Alternative edge restraints for flexible masonry paving.

1. Using a conventional mason's trowel, the pavers may be buttered and shoved into a leveling bed of mortar.

2. The units may be placed on a mortar leveling bed with $\frac{3}{8}$ - to $\frac{1}{2}$ -in. open joints into which a grout mixture is then poured. Grout proportions are normally the same as for the mortar, except that the hydrated lime may be omitted. Special care must be taken in pouring this mixture, to protect the unit surfaces from spills and stains that would require special cleaning.

3. Masonry pavers may also be laid on a cushion of 1 part portland cement and 3 to 6 parts damp, loose sand, and the open joints broomed full of the same mixture. After excess material has been removed from the surface, the paving is sprayed with a fine water mist until the joints are satu-

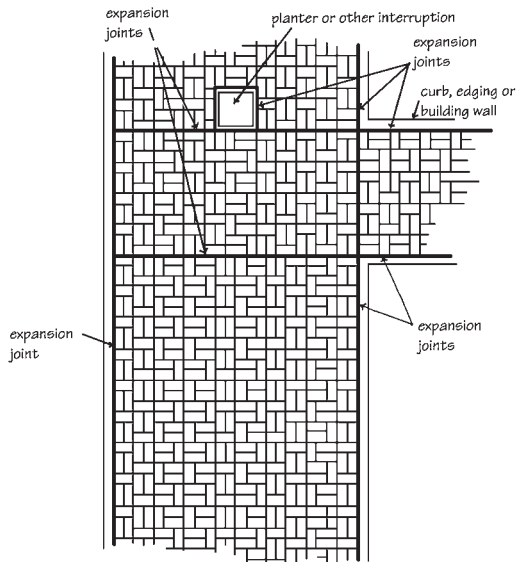


Figure 14-6 Expansion joint locations in rigid brick paving. (From Beall, *Masonry and Concrete for Residential Construction*, McGraw-Hill Complete Construction Series, 2001.)

rated. The installation should then be maintained in a damp condition for 2 or 3 days to facilitate proper curing.

Mortarless masonry paving may be swept with plain dry sand to fill between units, or with a portland cement–sand mixture equivalent to the proportions for Type M mortar. Pavers are generally butted together with only the minimal spacing between adjacent units caused by irregularities of size and shape.

Expansion joints must be provided in rigid masonry paving to accommodate thermal and moisture movements. Joints should generally be located parallel to curbs and edges, at 90° turns and angles, and around interruptions in the paving surface (see Fig. 14-6). Fillers for these joints must be compressible and made of materials not subject to rot or vermin attack. Solid or preformed materials of polyvinyl chloride, butyl rubber, neoprene, and other elastic compounds are suitable (see Fig. 14-7). Even though mortarless masonry paving is flexible and has the ability to move slightly to accommodate expansion and contraction, it is recommended that expansion joints be placed adjacent to fixed objects such as curbs and walls.

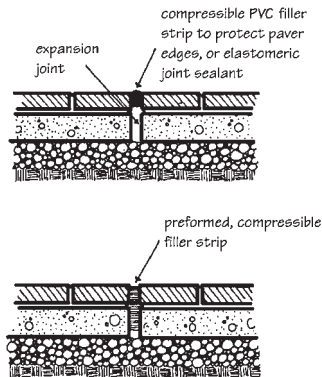


Figure 14-7 Expansion joints for rigid brick paving. (From BIA Technical Note 14A.)

14.1.5 Membrane Materials

Membranes of sheet or liquid materials are installed in some paving applications to reduce or control the passage of moisture, to discourage weed growth, or to form a separating layer or bond break to accommodate differential movement. Roofing felt, polyethylene film, vinyl, neoprene, rubber, asphaltic liquids, modified urethane, or polyurethane bitumens are all suitable since they are moisture- and rot-resistant. Liquid types, if installed properly, have some advantages over sheet materials because they are seamless and will conform to irregular surfaces. Precautions should be taken during construction to avoid membrane damage, particularly for roof deck installations, where resistance to moisture penetration is critical.

14.1.6 Masonry Units

The materials available for masonry paving systems have a wide range of structural and aesthetic capabilities. Solid concrete pavers are manufactured in a variety of shapes and sizes. ASTM C936, *Standard Specification for Solid Concrete Interlocking Paving Units*, requires that minimum compressive strength be 8000 psi. Lightweight and normal weight aggregates may be used. Dense compaction assures a minimum of voids, and absorption must be less than 5%. The interlocking patterns transfer loads and stresses laterally by an arching or bridging action. Distribution of loads over a larger area in this manner reduces point loads, allowing heavier traffic over sub-bases that would normally require greater strength. Some pavers are manufactured with chamfered edges at the top to reduce stress concentrations and chippage. Chamfers should not, however, reduce the area of the bearing surface by more than 30%.

Solid units are made in thicknesses ranging from $2\frac{1}{2}$ to 6 in. The thicker units are used for heavy service loads, and the thinner ones for light-duty residential areas. Individual solid paving units are small in size to facilitate manual installation. The irregular shapes prevent accurate description by linear measure, but units typically will range in size from 15 sq in. to a maximum of about 64 sq in. Some manufacturers are now casting from 6 to 12 units together in clusters that are designed to be laid at the job site by machine or by a team of two workers. After the units are in place, the individual pavers break apart along preformed cleavage lines. This method increases production and can result in a reduced labor costs.

Concrete paver shapes come in full-size units for field areas, but most designs also include edge units and half-length units to reduce the amount of job-site cutting required. Units are generally produced in a number of colors, but both color and shape will depend on local availability. Before planning the size and layout of a paved area, check with local manufacturers to verify design-related information.

Concrete grid pavers are popular for applications where soil stabilization is required but a natural grass covering is also desirable. ASTM C1319, *Standard Specification for Concrete Grid Paving Units*, requires an average compressive strength of 5000 psi and a maximum average water absorption of 10%. Physically, the units are permitted a maximum 50% void area, and must have a minimum $1\frac{1}{8}$ -in. web thickness. Durability standards are based solely on proven field performance in maintaining the required compressive strength and water absorption characteristics after three years in service. Minimum nominal thickness is $3\frac{1}{8}$ in., and maximum dimensions are 24×24 in. Features such as weight classification, surface texture, color, and finish are not covered in the standard and must be specified separately. Availability of specific unit patterns, shapes, and colors will vary locally.

Clay brick paving units also come in a number of shapes, sizes, thicknesses, colors, and textures. Coarser-textured, slip-resistant units are recommended for outdoor installations exposed to rain, snow, and ice. This type of exposure also calls for units that are highly resistant to damage from freezing in the presence of moisture. For residential and light commercial applications such as patios, walkways, floors, plazas, and driveways, brick pavers should meet or exceed the requirements of ASTM C902, *Standard Specification for Pedestrian and Light Traffic Paving Brick*. Three weathering classifications are given, Classes SX, MX, and NX, roughly corresponding to the three grades of face brick for severe weathering, moderate weathering, and no weathering exposure. Traffic Type I, II, or III may be specified for exposure to extensive abrasion, intermediate traffic, or low traffic, respectively.

For paving in areas with a high volume of heavy vehicular traffic such as streets, commercial driveways, and aircraft taxiways, brick pavers should meet or exceed the requirements of ASTM C1272, *Standard Specification for Heavy Vehicular Paving Brick*. The standard covers two types of pavers. Type R (rigid paving) is intended to be set in a mortar setting bed supported by an adequate concrete base or an asphalt setting bed supported by an adequate asphalt or concrete base. Type F (flexible paving) is intended to be set in a sand bed with sand joints. Three different applications are also covered, PS, PX, and PA, roughly corresponding to appearance types FBS, FBX, and FBA for clay facing brick. Because they are intended to be installed over a flexible base, Type F pavers must have the highest compressive strength at 10,000 psi. Type R pavers that will be supported on an asphalt or concrete base must have a minimum average compressive strength of only 8000 psi.

Heavy vehicular paving brick is obviously intended to be more rugged and durable in commercial, municipal, and industrial applications than pedestrian and light traffic pavers.

The Brick Industry Association (BIA) does not recommend the use of salvaged or used brick in paving installations. Older manufacturing processes did not assure uniformity in the quality of materials or performance, and units may spall, flake, pit, and crack when exposed to outdoor freeze-thaw cycles. Although used brick may be adequate for small residential jobs, and may provide a pleasing rustic effect, materials of unknown origin and composition should not be used for larger installations unless performance criteria can be tested and verified.

14.1.7 Paving Patterns

Many different effects can be achieved with standard rectangular pavers by varying the bond pattern in which the units are laid (see Fig. 14-8). It is important to specify the proper size of unit required for a particular pattern. Any of the patterns shown can be achieved with 4×8 -in. *actual dimension* units laid dry and tight, or with nominal 4×8 -in. units ($3\frac{5}{8} \times 7\frac{7}{8}$ -in. *actual size*) laid with $\frac{3}{8}$ -in. mortar or sand joints. Patterns that require the width of the unit to be exactly one-half the length may not be laid dry and tight using nominal dimension units designed for mortar joints, and vice versa. The interlocking and herringbone patterns provide greater stability and lateral stress transfer. Designs that result in continuous joints (especially longitudinal joints in the direction of traffic flow) are more subject to shoving, displacement, and the formation of ruts.

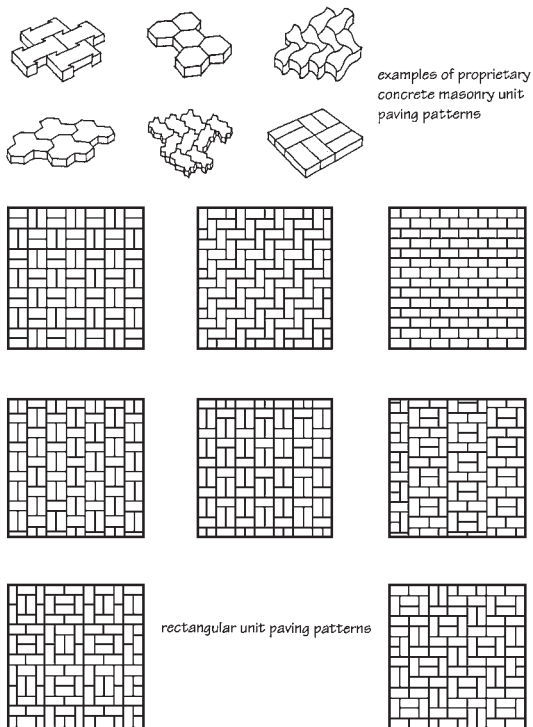
14.1.8 Brick Steps

For rigid brick paving systems, sharp changes in grade can be accommodated by constructing brick steps. Unit size affects riser height. There are four different ways of creating risers using different paver thickness, either laying the bricks flat (see Fig. 14-9) or setting them on edge (see Fig. 14-10), and varying the mortar joint thickness from $\frac{3}{8}$ to $\frac{1}{2}$ in. This gives some flexibility in achieving the exact riser height needed. The exposed length of the pavers as shown produces a tread width of 12 in. Overall width should be a multiple of 8 in. to accommodate the use of $2\frac{1}{2}$ -in.-thick pavers that are either laid on edge or laid flat. A 4-in.-thick stepped concrete base reinforced with welded wire fabric or reinforcing bars should be used to support the brick steps (see Fig. 14-11). Either slope the surface of the treads on the concrete base for drainage, or pour the concrete flat and slope the brick treads by varying the mortar bed thickness.

14.2 FIREPLACES

Residential fireplace design has evolved over the centuries toward standardization of the functional elements that assure successful operation. A fireplace must have proper fuel combustion, good chimney draw, and maximum heat radiation. Design should also provide simplicity of construction and fire safety, particularly when adjacent building elements are of combustible materials.

The proper functioning of a fireplace is related to the shape and relative dimensions of the combustion chamber or fire box, the proper location of the fireplace throat in relation to the smoke shelf, and the ratio of the flue area to the area of the fireplace opening (see Fig. 14-12). The shape of the combustion



For vehicular traffic on flexible sand bed paving, long continuous joints should be oriented perpendicular to the direction of travel. Patterns without long continuous joints are more stable against sliding, displacement, and the formation of ruts from the repeated braking and acceleration of vehicles.

Figure 14-8 Masonry paving patterns.

chamber influences both the draft and the amount of heat radiated into the room. The dimensions recommended in the tables may be varied slightly to correspond with brick coursing for modular and non-modular unit sizes, but it is inadvisable to make significant changes. A multifaced fireplace can be a highly effective unit, but presents certain problems of draft and opening size that must sometimes be solved on an individual basis. The single-face fireplace is the most common and the oldest design, and the majority of the standard detail information is based on this type. ASTM C315, *Standard Specification for Clay Flue Linings*, covers minimum material requirements,

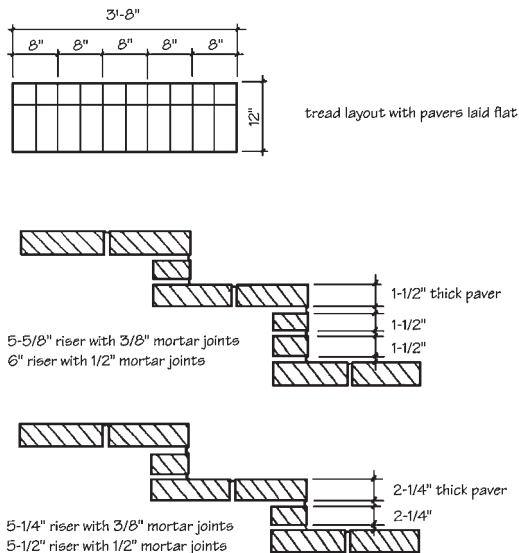


Figure 14-9 Brick steps using flat pavers. (From Beall, *Masonry and Concrete for Residential Construction*, McGraw-Hill Complete Construction Series, 2001.)

and ASTM C1283, *Standard Practice for Installing Clay Flue Lining*, covers minimum installation requirements for residential masonry chimneys not exceeding 40 ft in height. Code requirements for fireplace details and dimensions are shown in *Fig. 14-13* and the section drawings in *Figs. 14-14* and *14-15*. Flue size requirements are shown in *Fig. 14-16*.

In seismic areas, masonry chimneys must be designed to withstand large lateral forces, and must be anchored to the building frame to prevent overturning. Adequate foundation size and strength are critical for stability in any exposure. Flashing and counterflashing details are shown in *Fig. 14-17*.

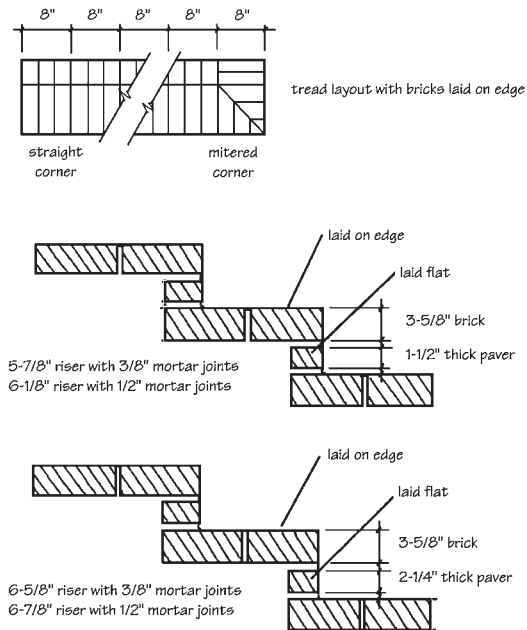


Figure 14-10 Brick steps using flat pavers and bricks on edge. (From *Beall, Masonry and Concrete for Residential Construction, McGraw-Hill Complete Construction Series, 2001.*)

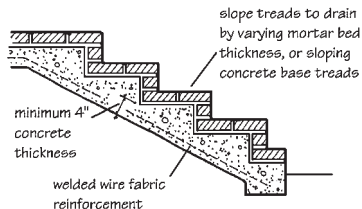
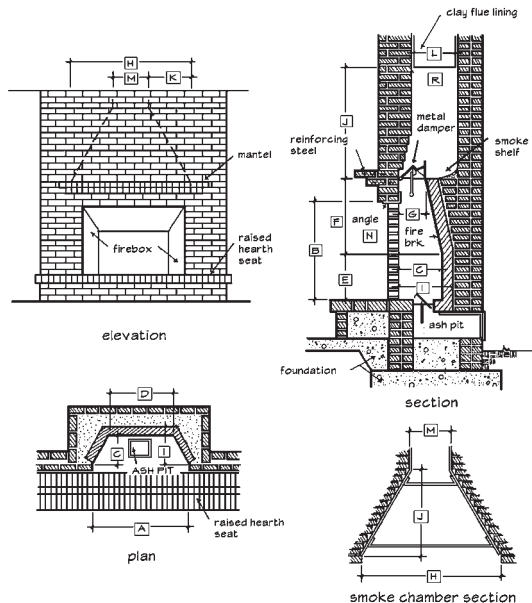


Figure 14-11 Brick steps laid on concrete base. (From *Beall, Masonry and Concrete for Residential Construction, McGraw-Hill Complete Construction Series, 2001.*)



Finished Fireplace Opening (in.)							Rough Brick Work and Flue Sizes (in.)								Steel Angles
A	B	C	D	E	F	G	H	I	J	K	L	M	R†	N	
24	24	16	11	14	18	8-3/4	32	20	19	10	8	12	8	A-36	
26	24	16	13	14	18	8-3/4	34	20	21	11	8	12	8	A-36	
28	24	16	15	14	18	8-3/4	36	20	21	12	8	12	10	A-36	
30	29	16	17	14	23	8-3/4	38	20	24	13	12	12	10	A-36	
32	29	16	19	14	23	8-3/4	40	20	24	14	12	12	10	A-42	
36	29	16	23	14	23	8-3/4	44	20	27	16	12	12	12	A-42	
40	29	16	27	14	23	8-3/4	48	20	29	16	12	16	12	A-48	
42	32	16	29	14	26	8-3/4	50	20	32	17	16	16	12	A-48	
48	32	18	33	14	26	8-3/4	56	20	37	20	16	16	15	B-54	
54	37	20	37	16	29	13	69	24	45	26	16	16	15	B-60	
60	37	22	42	16	29	13	72	27	45	26	16	20	15	B-66	
60	40	22	42	16	31	13	72	27	45	26	16	20	18	B-66	
72	40	22	54	16	31	13	84	27	56	32	20	20	18	C-84	
84	40	24	64	20	28	13	96	29	61	36	20	24	20	C-96	
96	40	24	76	20	28	13	108	29	75	42	20	24	22	C-108	

§ Angle Sizes: A = 3 x 3 x 3/16, B = 3-1/2 x 3 x 1/4, C = 5 x 3-1/2 x 5/16.

† Round flues.

Figure 14-12 BIA fireplace details and dimensions. (From Harry C. Plummer, Brick and Tile Engineering.)

Masonry Fireplace and Chimney Requirements		
Item	Letter Designation [§]	Requirements
Hearth and hearth extension thickness	A	4 in. minimum thickness for hearth, 2 in. minimum thickness for hearth extension
Hearth extension (each side of opening)	B	8 in. for fireplace opening less than 6 sq.ft; 12 in. for fireplace opening equal to or greater than 6 sq.ft.
Hearth extension (front of opening)	C	16 in. for fireplace opening less than 6 sq.ft; 20 in. for fireplace opening equal to or greater than 6 sq.ft.
Firebox dimensions	D	20 in. minimum firebox depth; 12 in. minimum firebox depth for Rumford fireplaces
Hearth and hearth extension reinforcing	D	Reinforced to carry its own weight and all imposed loads
Thickness of firebox wall	E	10 in. solid masonry or 8 in. where firebrick lining is used
Distance from top of opening to throat	F	8 in. minimum
Smoke chamber wall thickness dimensions	G	6 in. lined; 8 in. unlined; not taller than opening width; walls not inclined more than 45 degrees from vertical for prefabricated smoke chamber lining or 30 degrees from vertical for corbeled masonry
Chimney vertical reinforcing	H	Four No. 4 full-length bars for chimney up to 40 in. wide; add two No. 4 bars for each additional 40 in. or fraction of width, or for each additional flue
Chimney horizontal reinforcing	J	1/4 in. ties at each 18 in. and two ties at each bend in vertical steel
Bond beam	K	As determined by design.
Fireplace lintel	L	Noncombustible material with 4 in. bearing length at each side of opening
Chimney walls with flue lining	M	4 in. thick solid masonry with 5/8 in. fireclay liner or equivalent; 1/2 in. grout or air space between fireclay liner and wall
Effective flue area (based on area of fireplace opening and chimney)	P	See graph in Figure 14-16
Clearances from chimney from fireplace combustible trim or materials above roof	R	2 in. interior, 1 in. exterior 2 in. back or sides 6 in. from opening 3 ft. above roof penetration, 2 ft. above any part of structure within 10 ft.
Anchorage strap number embedment into chimney fasten to bolts	S	3/16 in. x 1 in. two 12 in. hooked around outer bar with 6 in. extension four joists two 1/2 in. diameter
Footing thickness width	T	12 in. minimum 6 in. each side of fireplace wall

§ See section drawings on following pages.

Figure 14-13 Masonry fireplace and chimney details and dimension requirements. (From International Building Code 2003.)

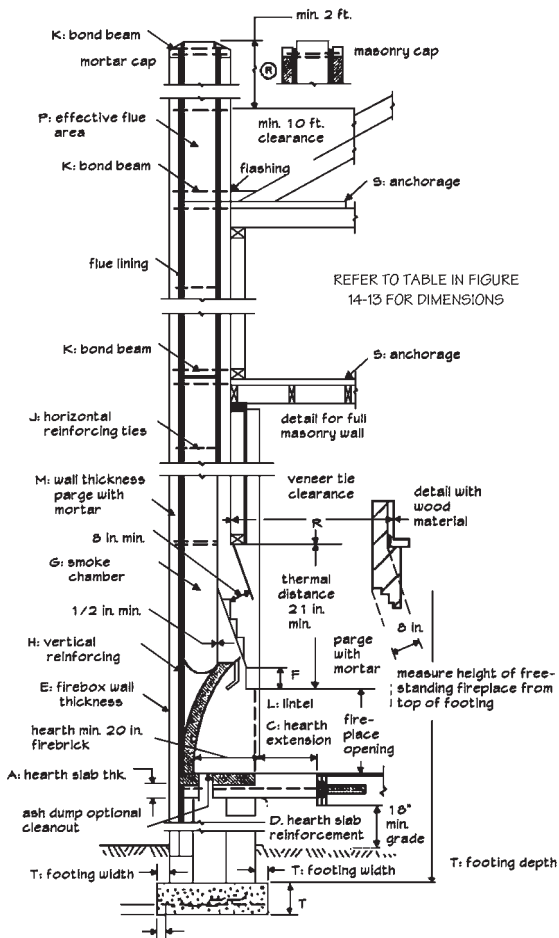
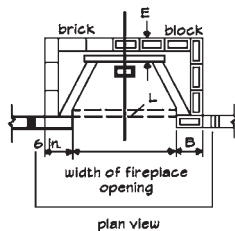


Figure 14-14 Section detail, fireplace on wood framing. (From International Building Code 2003.)



plan view

REFER TO TABLE IN
FIGURE 14-13 FOR
DIMENSIONS

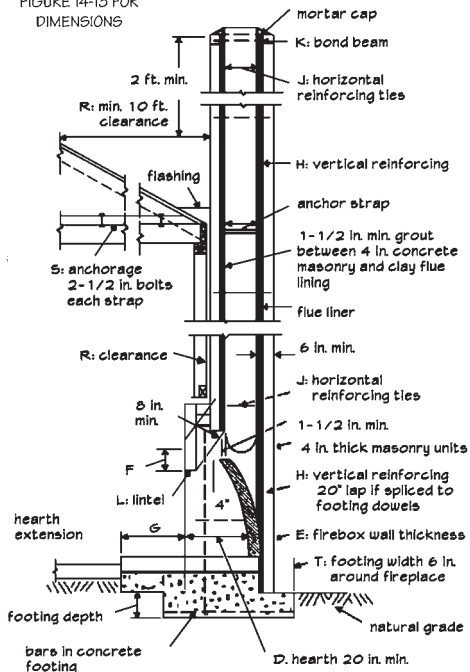


Figure 14-15 Section detail, fireplace on concrete slab. (From International Building Code 2003.)

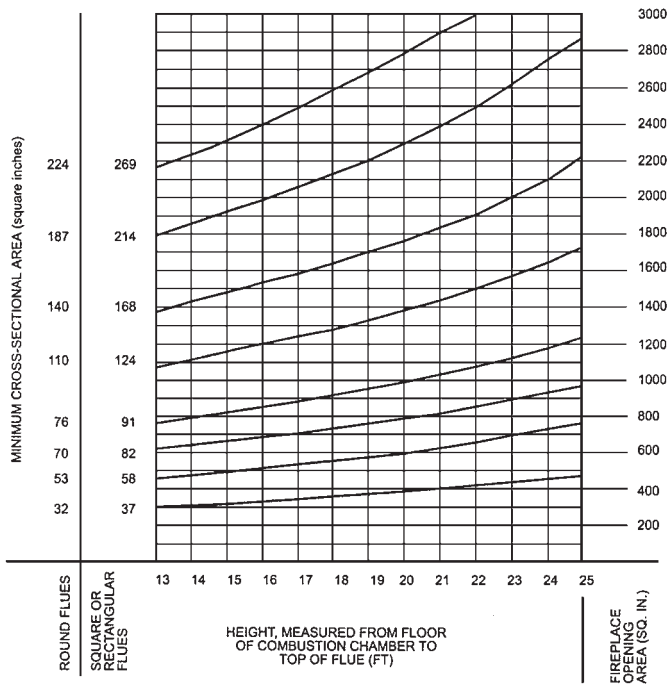


Figure 14-16 Flue size requirements for masonry chimneys. (From International Building Code 2003.)

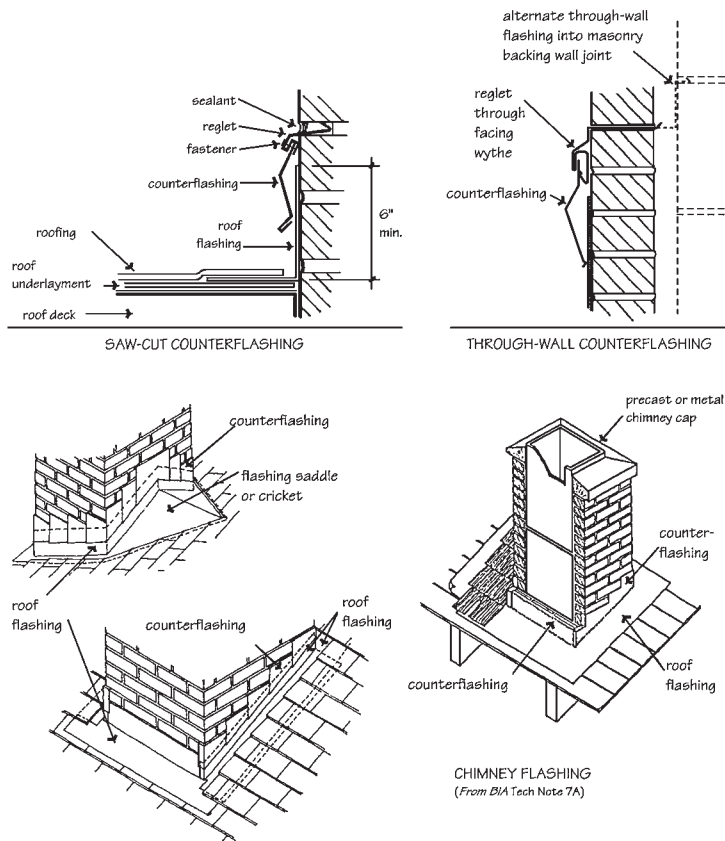


Figure 14-17 Flashing and counterflashing at masonry chimneys.

This page intentionally left blank.

PART **4**

CONSTRUCTION PRACTICE

This page intentionally left blank.

15

INSTALLATION AND WORKMANSHIP

Masons and bricklayers belong to one of the oldest crafts in history. The rich architectural heritage of many civilizations attests to the skill and workmanship of the trade, and the advent of modern technological methods and sophisticated engineering practices has not diminished the importance of this aspect of masonry construction. The best intentions of the architect or engineer will not produce a masterpiece unless the workmanship is of the highest order and the field practices are as exacting and competent as the detailing.

15.1 MOISTURE RESISTANCE

Workmanship has a greater effect on the moisture resistance of masonry than any other single factor. Key elements in the quality of workmanship include:

- Proper storage and protection of materials
- Consistent proportioning and mixing of mortar ingredients
- Full mortar joints
- Complete mortar-to-unit bond
- Continuity of flashing
- Unobstructed weep holes
- Tooled joint surfaces
- Protection of uncompleted walls

Among these elements, mortar placement ranks high in limiting the amount of moisture that penetrates through the wall face. Such leakage can usually be traced to either capillary passages at the mortar-to-unit interface, partially filled mortar head joints, or cracks caused by unaccommodated building movements. Virtually all masonry walls suffer some moisture penetration because of joint defects and other design, construction, or workmanship

errors. It is for this reason that the installation of flashing and weep holes is critical in collecting and draining any water that does enter the wall. This backup drainage system provides redundancy in moisture control and allows the construction to be somewhat forgiving of defects. Since it *is* the backup system, though, the flashing installation itself cannot tolerate defects or discontinuities without providing avenues for moisture penetration directly to the interior of the building.

15.2 PREPARATION OF MATERIALS

Field quality control begins with the proper storage and protection of materials. Preparations necessary prior to construction will vary according to the specific materials and conditions involved.

15.2.1 Material Storage and Protection

Proper storage and protection of masonry materials at the project site are critical to the performance and appearance of the finished construction. Materials properly stored and covered will remain in good condition, unaffected by weather. Improper procedures, however, can result in damage to units and contamination or degradation of mortar and grout ingredients.

Brick and block units should be stored off the ground to prevent staining from contact with the soil and absorption of moisture, soluble salts, or other contaminants that might cause efflorescence in the finished work. Stored units should be covered for protection against the weather. Cut stone usually requires stacking on wooden pallets or frames with spacers between panels to allow air circulation. Treated wood may contain chemicals that stain light-colored stone. Handling of all masonry should avoid chipping or breakage of units.

Mortar and grout aggregates should also be covered to protect against contamination from rain, snow, ice, and blowing dust and debris. Different aggregates should be stockpiled separately. Packaged mortar and grout ingredients should be received in their original containers with labels intact and legible for easy identification. Broken packages, open containers, and materials with missing or illegible identification should be rejected. All packaged materials should be stored off the ground and covered to prevent moisture penetration, deterioration, and contamination.

15.2.2 Mortar and Grout

The mortar mix required in the project specifications must be carefully controlled at the job site to maintain consistency in performance and appearance. Consistent measurement of mortar and grout ingredients should ensure uniformity of proportions, yields, strengths, workability, and mortar color from batch to batch. Volumetric rather than weight proportioning is most often called for, and most often miscalculated because of variations in the moisture content of the sand. Common field practice is to use a shovel as the standard measuring tool for dry ingredients. However, moisture in the sand causes a “bulking” effect, and the same weight of wet sand occupies more volume than dry sand. Such variables often cause over- or undersanding of the mix, which affects both the strength and bonding characteristics of the mortar. Oversanded mortar is harsh and unworkable, provides a weak bond with the masonry units, and performs poorly during freeze-thaw cycles.

Simple field quality control measures can be instituted through the use of 1 cu ft measuring boxes (see Fig. 15-1A). The mixer may then determine

how many shovels of sand equal 1 cu ft. Since the moisture content of the sand will vary constantly because of temperature, humidity, and evaporation, it is good practice to check the volume measurement at least twice a day and make adjustments as necessary. For even greater consistency, a site-constructed or proprietary batching box can be set to discharge as much as 9 cu ft of sand directly into the mixer (see Fig. 15-1B).

The other dry ingredients in masonry mortar are normally packaged and labeled only by weight. Regardless of weight, however, these cementitious materials are usually charged into the mixer in whole or half bag measures. Each bag of portland cement or masonry cement equals 1 cu ft regardless of its labeled weight, and each bag of hydrated mason's lime equals $1\frac{1}{4}$ cu ft regardless of its weight. In some regions, additional convenience is provided by preblended and bagged portland cement-lime mixes.

Increases in moisture content cause a "bulking effect" in sand. Any given weight of wet sand occupies more volume than the same weight of dry sand, so sand volume may vary throughout the day and from day to day as its moisture content changes.

MEASURING SAND SIMPLY BY COUNTING SHOVELS IS NOT AN ACCURATE METHOD OF BATCHING MASONRY MORTAR AND IS NOT RECOMMENDED.

The illustrations below show two alternative methods for accurately measuring sand volume.

- Figure A shows measuring boxes being used to check the number of shovels of sand it takes for 1 cubic foot. Measuring boxes should be used at least twice a day to check sand volume, once in the morning and again after lunch.
- Figure B shows a batching box in which the sand is shoveled into a 1 cubic foot measure and then discharged into the mixer from the box. This method is more accurate and accounts for continuous volume changes in the sand as it dries or bulks with moisture changes.

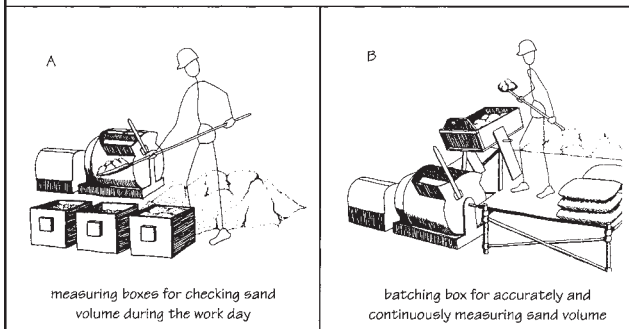


Figure 15-1 Measuring and batching sand for masonry mortar. (From BIA Technical Note 8B.)

The amount of mixing water required is not stated as part of the project specifications. Unlike concrete, however, masonry mortar and grout require the *maximum* amount of water consistent with characteristics of good flow and workability. Excess water is rapidly absorbed by the masonry units, reducing the water-cement ratio to normal levels and providing a moist environment for curing. Optimum water content is best determined by the mason's feel of the mortar on the trowel. A mortar with good workability is mixed with the proper amount of water.

Mortar with good workability should spread easily, cling to vertical unit surfaces, extrude easily from joints without dropping or smearing, and permit easy positioning of the unit to line, level, and plumb. Dry mixes do not spread easily, produce poor bond, and may suffer incomplete cement hydration. Mixes that are too wet are difficult to trowel and allow units to settle after placement. So mixing water additions are self-regulating. The water proportion will vary for different conditions of temperature, humidity, unit moisture content, unit weight, and so on.

The necessary water content for grout is significantly higher than that for mortar, because grout must flow readily into the cores and cavities and around reinforcement and accessories. Grout consistency should be such that at the time of placement, the grout has a slump of 8 to 11 in. (see Fig. 15-2).

Recent innovations in masonry technology include ready-mixed mortars and prebatching of dry mortar ingredients to eliminate the field variables that often affect the quality and consistency of job-mixed mortar. This moves the mixing operation to a controlled batching plant where ingredients can be accurately weighed and mixed, then delivered to the job site. Ready-mixed mortars are delivered trowel-ready in trucks or sealed containers, without the need for additional materials or mixing. Extended-life set retarders, which keep the mix plastic and workable for up to 72 hours, must be absorbed by the masonry units before cement hydration can begin, so unit suction can affect set time and construction speed. Prebatched dry ingredients are delivered to the site in weathertight silos ready for automatic mixing (see Fig. 15-3). Both methods improve uniformity and offer greater convenience and efficiency, but sand bulking can still be a problem with dry-batched mixes unless the sand is oven-dried. Ready-mixed mortars are governed by ASTM C1142, *Standard Specification for Ready-Mixed Mortar for Unit Masonry*.

There are two traditional methods of mixing mortar on the job site. For very small installations, *hand mixing* may be most economical. It is accomplished using a mason's hoe and a mortar box. Sand, cement, and lime are spread in the box in proper proportions and mixed together until an even color is obtained. Water is then added, and mixing continues until the consistency and workability are judged to be satisfactory.

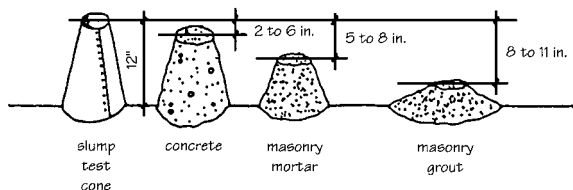
More commonly, *machine mixing* is used to combine mortar ingredients. The mechanical drum or paddle-blade mixers used are similar to but of lighter duty than concrete mixers. Normal capacity ranges from 4 to 7 cu ft. About three-fourths of the mixing water, half the sand, and all of the cementitious ingredients are first added and briefly mixed together. The balance of the sand is then added, together with the remaining water. After all the materials and water have been combined, grout should be mixed a minimum of 5 minutes, and mortar a minimum of 3 and a maximum of 5 minutes. Less mixing time may result in non-uniformity, poor workability, low water retention, and less than optimum air content. Overmixing causes segregation of materials and entrapment of excessive air, which may reduce bond strength.



Grout with a water-cement ratio and slump similar to concrete is too dry and stiff for use in masonry. It will not flow into unit cores and wall cavities to properly fill voids and encapsulate reinforcing steel and connectors.



Masonry grout should have a fluid consistency for pouring or pumping into small spaces that are often congested with reinforcing steel.



Concrete	Masonry Mortar	Masonry Grout
Concrete is generally mixed with the <i>minimum</i> amount of water required to produce workability appropriate to the method of placement. The amount of water is determined by laboratory mix design.	Masonry mortar is generally mixed with the <i>maximum</i> amount of water required to produce good workability with a given unit. The amount of water is determined by the mason based on masonry unit absorption and field conditions.	Masonry grout is usually mixed with the <i>maximum</i> amount of water required to produce good flow properties. The amount of water is determined by the mason based on masonry unit absorption and field conditions.

Figure 15-2 Masonry grout should be a fluid consistency with a slump of 8 to 11 in.

Specified admixtures and pigments should be added in the approved quantities only after all other ingredients are mixed. Pigments should always be prebatched for consistency in color.

To avoid excessive drying and stiffening, mortar batches should be sized according to the rate of use. Loss of water by absorption and evaporation can be minimized on hot days by wetting the mortar board and covering the mix in the mortar box. Within the first $1\frac{1}{2}$ to $2\frac{1}{2}$ hours of initial mixing, the mason may add water to replace evaporated moisture (refer to Chapter 6). *Retempering* is accomplished by adding water to the mortar batch and thoroughly remixing. Sprinkling of the mortar is not satisfactory. Mortars containing added color pigment should not be rettempered, as the increased water will lighten the color and thus cause variation from batch to batch.

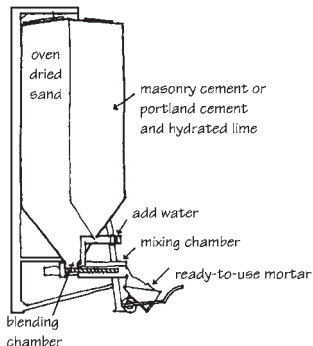


Figure 15-3 Mortar silo.

15.2.3 Masonry Units

Concrete masonry units are cured and dried at the manufacturing plant, and should never be moistened before or during placement because they will shrink as they dry out. If this shrinkage is restrained, as it normally is in a finished wall, stresses can develop that will cause the wall to crack.

When brick is manufactured, it is fired in a high-temperature kiln which drives virtually all of the moisture out of the wet clay. Fired bricks are extremely dry until they absorb enough moisture from the air to achieve a state of moisture equilibrium with their surroundings. Brick that is very dry when it is laid causes rapid and excessive loss of mixing water from the mortar, which results in poor adhesion, incomplete bond, and water-permeable joints of low strength. Brick that is very dry and absorptive is said to have a high initial rate of absorption (IRA) or high suction. Optimum mortar bond is produced with units having initial rates of absorption between 5 and 25 g/min/30 sq in. (refer to Chapter 3). If the IRA is higher than 30 g/min/30 sq in., the units should be wetted with a garden hose the day before they will be used so that moisture is fully absorbed into the units but the surfaces are dry to the touch before being laid. Visual inspection of a broken brick will indicate whether moisture is evenly distributed throughout the unit (see Fig. 15-4). A surface film of water will cause the brick to float. Where prewetting of units is not possible, the time lapse between spreading the mortar and laying the unit should be kept to a minimum. Some experts recommend that brick not be wetted in winter because some high-suction units produce better bond strength in cold weather than low-suction units.

A simple field test can be performed to determine whether brick should be prewetted. Draw a circle the size of a quarter on the bed surface of a unit, using a crayon or wax pencil. With a medicine dropper, place 12 drops of water inside the circle and time how long it takes for them to be absorbed (see Fig. 15-5). If the water is completely absorbed in less than 1 minute, the brick is too dry and should be wetted.

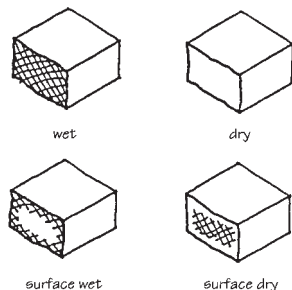


Figure 15-4 Visual inspection of moisture distribution within a brick. (From BIA Technical Note 17C.)

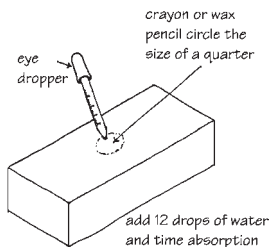


Figure 15-5 Simple field test to identify high-suction brick that should be prewetted before use.

Brick and architectural concrete masonry units must also be properly blended for color to avoid uneven visual effects. Units from four different cubes or pallets should be used at the same time, and brick manufacturers often provide unstacking instructions for even color distribution. For single-color units, this takes advantage of the subtle shade variations produced in the manufacturing process, and on a blend of colors, will prevent stripes or patchy areas in the finished wall (see Fig. 15-6). The wider the range of colors, the more difficult it is to get a uniform blend.

All masonry units should be clean and free of contaminants such as dirt, oil, or sand, which might inhibit bond.

15.2.4 Accessories

Steel reinforcement, anchors, ties, and other accessories should be cleaned to remove oil, dirt, ice, and other contaminants that could prevent good bond with the mortar or grout. Careful storage and protection will minimize cleaning



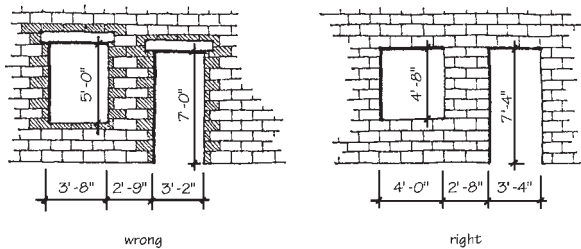
Figure 15-6 Masonry units must be properly blended for uniform color distribution.

requirements. Flashing materials should be protected from damage or deterioration prior to placement, and insulation materials protected from wetting.

15.2.5 Layout and Coursing

The design of masonry buildings should take into consideration the size of the units involved. The length and height of walls as well as the location of openings and intersections will greatly affect both the speed of construction and the appearance of the finished work. The use of a common module in determining dimensions can reduce the amount of field cutting required to fit the building elements together.

A number of the common brick sizes available are adaptable to a 4- or 6-in. module, and dimensions based on these standards will generally result in the use of only full- or half-size units. Similarly, a standard 16-in. concrete block layout may be based on an 8-in. module with the same reduction in field cutting (see *Fig. 15-7*). In composite construction of brick and concrete block, unit selection should be coordinated to facilitate the anchorage of backing and facing wall, as well as the joining and intersecting of the two systems. The table shown in *Fig. 15-8* gives vertical and horizontal coursing for modular brick and 8-in. concrete block. Three courses of standard modular brick equal the height of one concrete block course. As shown in *Fig. 15-9*, the brick and block units work together in both plan and section, thus increasing the speed with which the mason can lay up a wall and improving the general quality, workmanship, and appearance of the job.



shaded areas indicate units
requiring field cutting

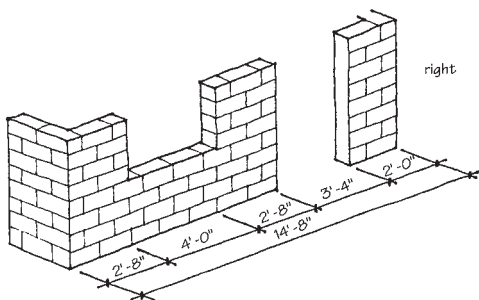
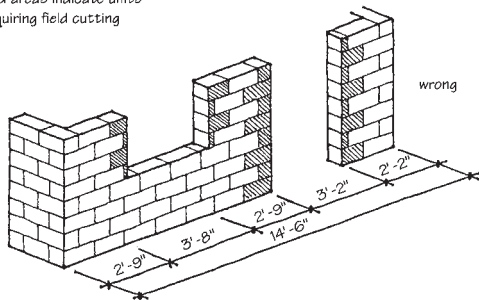


Figure 15-7 Wall openings based on $8 \times 8 \times 16$ CMU. (From NCMA TEK Bulletin 14.)

Vertical Coursing			Horizontal Coursing		
Number of Brick and Bed Joint Courses	Number of Concrete Block and Bed Joint Courses	Wall Height	Number of Brick and Head Joint Courses	Number of Concrete Block and Head Joint Courses	Wall Length
1		2-11/16"	1		8"
2		5-5/16"	2	1	1'-4"
3	1	8"	3		2'-0"
6	2	1'-4"	4	2	2'-8"
9	3	2'-0"	5		3'-4"
12	4	2'-8"	6	3	4'-0"
15	5	3'-4"	7		4'-8"
18	6	4'-0"	8	4	5'-4"
21	7	4'-8"	9		6'-0"
24	8	5'-4"	10	5	6'-8"
27	9	6'-0"	11		7'-4"
30	10	6'-8"	12	6	8'-0"
33	11	7'-4"	13		8'-8"
36	12	8'-0"	14	7	9'-4"
39	13	8'-8"	15		10'-0"
42	14	9'-4"	16	8	10'-8"
45	15	10'-0"	17		11'-4"
48	16	10'-8"	18	9	12'-0"
51	17	11'-4"	19		12'-8"
54	18	12'-0"	20	10	13'-4"
57	19	12'-8"	21		14'-0"
60	20	13'-4"	22	11	14'-8"
63	21	14'-0"	23		15'-4"
66	22	14'-8"	24	12	16'-0"
69	23	15'-4"	25		16'-8"
72	24	16'-0"	26	13	17'-4"
			27		18'-0"
			28	14	18'-8"
			29		19'-4"
			30	15	20'-0"
			36	18	24'-0"
			42	21	28'-0"
			48	24	32'-0"

Figure 15-8 Modular coursing table for brick and block.

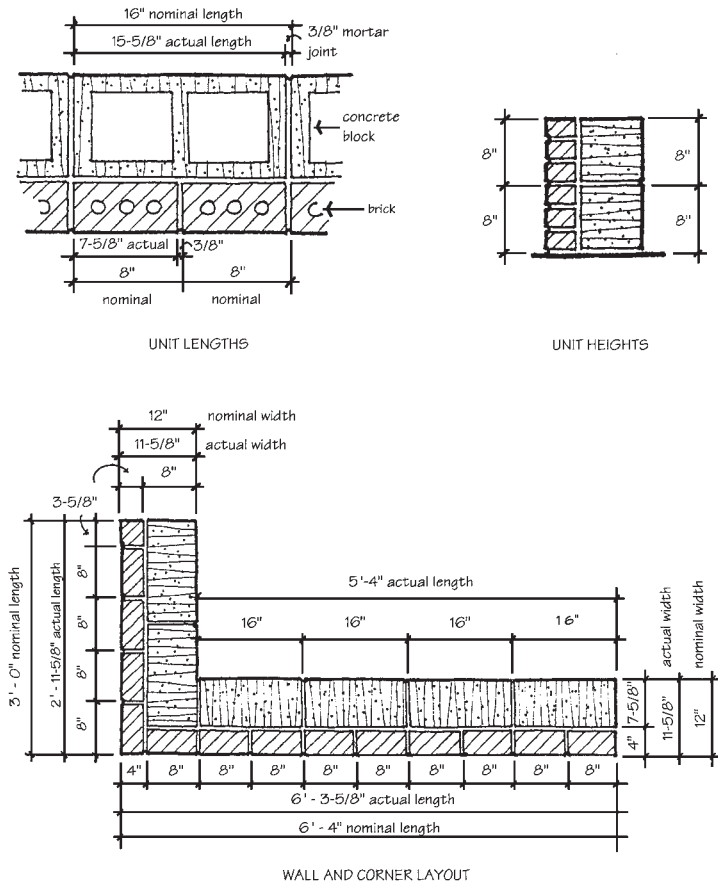


Figure 15-9 Brick and block coursing layout. (From *Beall, Masonry and Concrete for Residential Construction, McGraw-Hill Complete Construction Series, 2001.*)

Corners and intersections in masonry walls can be critical both structurally and aesthetically, and proper planning can facilitate construction of these elements. When masonry shear walls are used to transfer wind loads and seismic forces, they must be securely anchored to the intersecting walls with steel reinforcing, and the coursing and layout of the units affect the ease with which the steel can be placed. Corner intersections are often points of high stress, and must also be aesthetically pleasing from the exterior if the masonry units are to be left exposed. The use of masonry pilasters as integral stiffening elements in a wall must also be carefully considered in the layout, and dimensions properly set so that the pilaster fits in with the regular coursing. The examples in *Figs. 15-10 through 15-13* illustrate various common methods of detailing.

The laying up of masonry walls is a very ordered and controlled process. Units must remain in both vertical and horizontal alignment throughout the height and length of the structure in order for the coursing to work out with opening locations, slab connections, anchorage to other structural elements, and so on. Laying out of the first course is critical, since mistakes at this point would be difficult, if not impossible, to correct later. The first course must provide a solid base on which the remainder of the walls can rest.

After locating the corners of the structure, it is a good idea to check dimensions by either measuring or actually laying out a dry course of units. Chalk lines are used to establish initial alignment on the foundation, and string lines are used once the walls are up in the air. The base course at the foundation must always be laid in a full bed of mortar even if face shell bedding (for hollow brick or CMUs) is to be used in the rest of the wall.

Corner units are laid first, and walls worked from outside corners and openings toward the center. The corners are usually built four or five courses higher than the center of the wall, and as each course is laid, it is checked for level, plumb, and alignment. For filling in between the corners of a wall, a string line is stretched from end to end and the top outside edge of each unit is laid to this line. Use of the mason's level between corners is then limited to checking the face of the units to assure that they are in the same plane. This speeds construction time and assures greater accuracy.

A story pole or corner pole is used to simplify the accurate location of course heights. Story poles are generally of metal with adjustable coursing scales attached. The poles must be rigid enough to resist bending when a

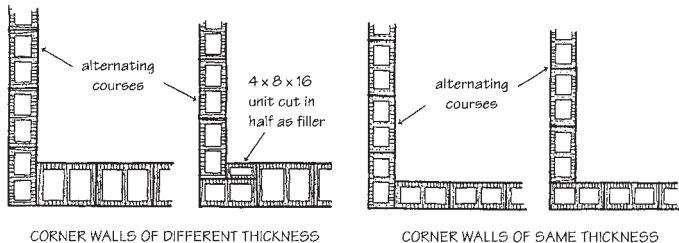


Figure 15-10 Modular CMU corner layouts.

50% of units (every other course) in overlapping bond at wall intersection

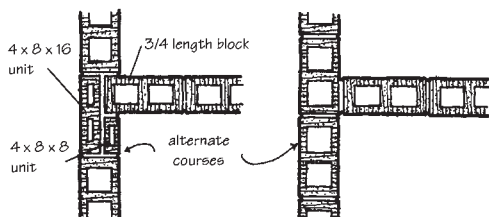
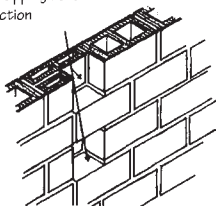


Figure 15-11 Masonry unit bonded wall intersection.

string line is pulled from one side, easily attachable to the masonry walls at the corners, and easily plumbed and maintained for the height of the wall.

15.3 INSTALLATION Masonry construction includes the placement of mortar, units, anchors, ties, reinforcement, grout, and accessories. Each element of the construction performs a specific function, and should be installed in accordance with recommended practice.

15.3.1 Mortar and Unit Placement

Mortar is the cementitious material that bonds units, connectors, and reinforcement together for strength and weather resistance. Although it contributes to the compressive strength of the assemblage, its primary functions are in providing flexural and tensile bond and in filling the joints between units against the passage of air and water. To perform these functions, it must be properly mixed and placed to achieve intimate contact with the unit surface and form both a physical and chemical bond (refer to Chapter 6).

Masonry walls with full head and bed joints are stronger and less likely to leak than walls with furrowed bed joints and lightly buttered head joints. Partially filled mortar joints reduce the flexural strength of masonry by as much as 50 to 60%, offer only minimal resistance to moisture penetration,

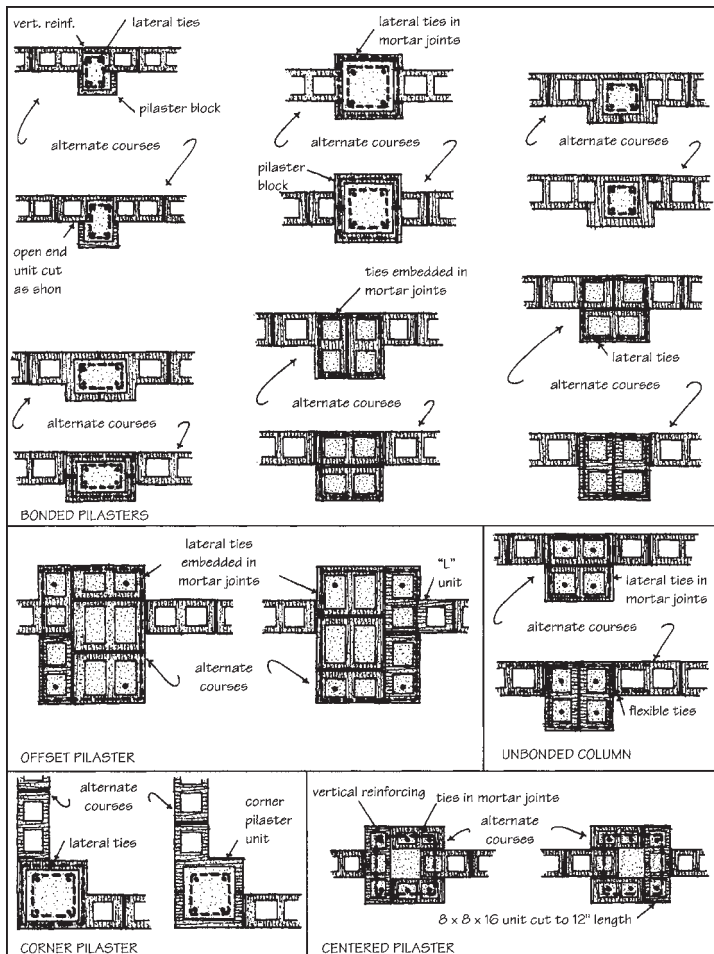


Figure 15-12 CMU pilaster and column coursing layout.

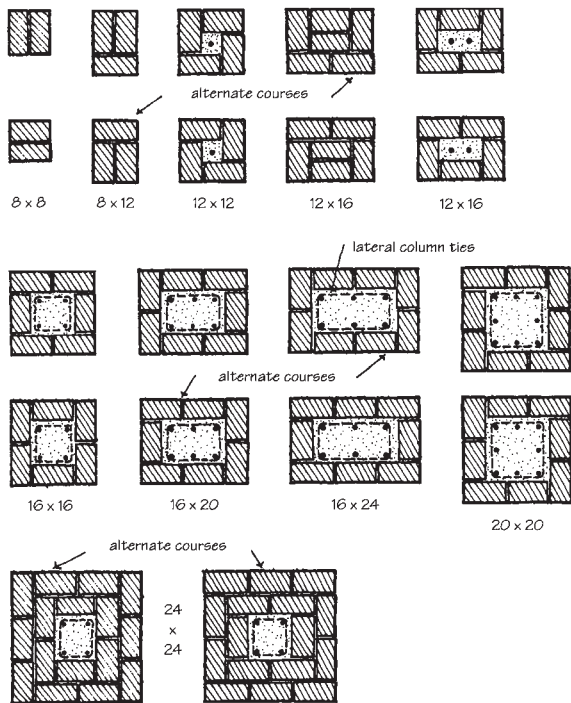


Figure 15-13 Brick column coursing. (From Harry C. Plummer, *Brick and Tile Engineering, and BIA Principles of Brick Masonry*.)

and may contribute to spalling and cracking if freezing occurs when the units are saturated. Bed joints should be laid full and unfurrowed, only slightly beveled away from the cavity to minimize mortar extrusion and droppings (see Fig. 15-14). The ends of the units should be fully buttered with mortar so that when they are shoved into place, mortar is extruded from the joint (see Fig. 15-15). Concrete block should always be laid with the thicker end of the face shell up to provide a larger mortar bedding area. For face shell bedding of hollow CMUs, only the end flanges of the face shells are buttered with mortar (see Fig. 15-16). Because of their weight and difficulty in handling, masons often stand several units on end and apply mortar to the flanges of three or four units at one time. Each block is then individually placed in its



mortar bridges can inhibit drainage and transport moisture across the cavity to the backing wall

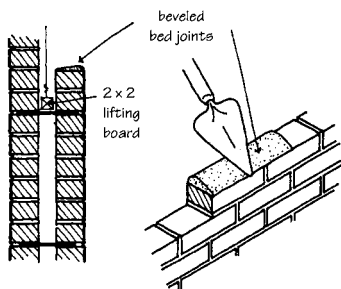


Figure 15-14 Beveled bed joints minimize mortar extrusions into the drainage cavity, and lifting boards can be used to remove mortar droppings. (From BIA Technical Note 21C.)

final position, tapped down into the mortar bed, and shoved against the previously laid block, thus producing well-filled vertical head joints at both faces of the masonry. When the last closure unit is installed in a course, all edges of the opening and all vertical edges of the unit should be buttered and the unit carefully lowered into place. If any of the mortar falls out, leaving a void in the joint, the closure unit should be removed and the operation repeated.

Bed joint mortar should be spread only a few units at a time so that the mortar will not dry excessively before the next course of units is placed. For both brick and block, a long mason's level is used as a straightedge to assure correct horizontal alignment. Units are brought to level and made plumb by light tapping with the trowel handle. This tapping, plus the weight of the unit and those above, helps form a good bond at the bed joint. Once the units have been laid, they cannot be adjusted or realigned by tapping without breaking the bond. If it is necessary to reposition the masonry, all the old mortar must be removed and replaced with fresh.

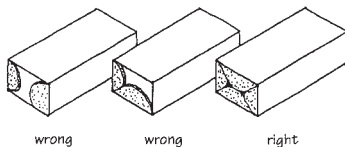
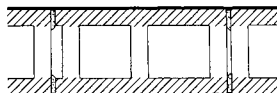
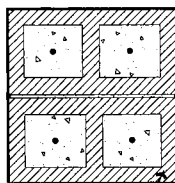


Figure 15-15 Fill head joints for better resistance to rain penetration. (From BIA Technical Note 17C.)



STANDARD FACE SHELL BEDDING

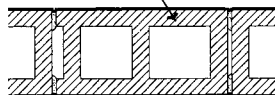
bed joints at face shells must be fully mortared, depth of head joints must be equal to thickness of face shell (in fully grouted walls, grout can flow laterally across webs for interlocking)



hatched area indicates mortar

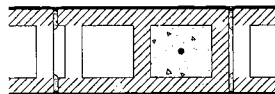
AT PIERS, COLUMNS AND PILASTERS

bed joints at face shells and webs must be fully mortared



FULL MORTAR BEDDING

bed joints at face shells and webs must be fully mortared only for the first course on foundations and when specified



AT GROUTED CORES

bed joints at face shells and webs around grouted cores must be fully mortared

Figure 15-16 Mortar bedding of hollow masonry units. (From Patterson, Illustrated 2000 Building Code Handbook, McGraw-Hill, 2001.)

In cavity wall and veneer wall construction, it is extremely important that the cavity between the outer wythe and the backing wall be kept clean to assure proper moisture drainage. If mortar clogs the cavity, it can form bridges for moisture passage, or it may block weep holes. Some masons use a removable wooden strip to temporarily block the cavity as the wall is laid up and prevent mortar droppings. However, beveling the mortar bed as shown in *Figure 15-14* allows little mortar to extrude into the cavity. Any mortar fins that do protrude into the cavity should be cut off or flattened to prevent interference with the placement of reinforcing steel, grout, or insulation. A cavity with a minimum clear dimension of 2 in. is not as easily bridged by mortar extrusions and can be kept clean much more easily than a narrow cavity. Codes generally require only a 1-in. minimum cavity width, and corrugated anchors cannot be used when the cavity exceeds 1 in. A 2-in.-wide cavity, however, is preferable for better drainage.

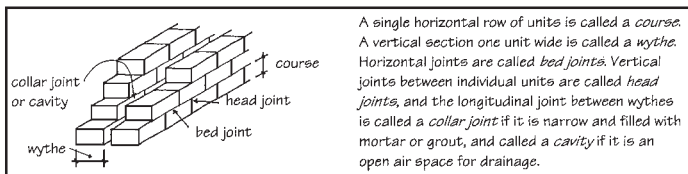
Use of the various types of insulation covered in Chapter 8 will affect the manner in which the masonry walls are laid up. In veneer construction over wood frame, the board or batt insulation and the corrugated metal ties are placed against the frame before the masonry work is begun. If rigid board insulation is used in insulated masonry cavity walls, the backing wall must be laid up higher than the facing wall so that the boards may be attached to it before the facing wythe covers it. If the masons are working overhand from inside the building (as they often do on multistory construction), this makes the insulating process more awkward, and therefore less economical. In these cases, the masons would work better from scaffolding on the outside of the building, but the cost of the installation would increase.

Loose fill insulation does not require that the two wythes of masonry be laid up separately. Both the inner and outer wythes can be laid up simultaneously, and the insulation poured or pumped into place at designated vertical intervals.

To add visual interest to masonry walls, units may be laid in different positions as shown in *Fig. 15-17*, and arranged in a variety of patterns (see *Figs. 15-18 and 15-19*). The patterns were originally conceived in connection with masonry wall bonding techniques that are not widely used today. In older work constructed without metal ties or reinforcement, rowlock and header courses were used to structurally bond the wythes of a wall together (refer to Chapter 12 for structural code requirements). Most contemporary buildings use the 1/3 or 1/2 running bond, or stack bond with very little decorative pattern work. In cavity wall construction, half rowlocks and half headers may be used for aesthetic effect on the exterior without the unit actually penetrating the full thickness of the wall (see *Fig. 15-20*).

Brick soldier and sailor courses should be installed carefully to prevent mortar from slumping in the tall head joints, leaving voids which might be easily penetrated by moisture. Units used for sailor or shiner courses must be solid and uncured. Vertical coursing between backing and facing wythes must also be coordinated to accommodate ties and anchors.

Masonry arches may be built of special brick or stone shapes to obtain mortar joints of constant thickness, or of standard brick units with joint thickness varied to obtain the required curvature. The method selected should be determined by the arch dimensions and by the desired appearance. It is especially important in a structural member such as an arch that all mortar joints be completely filled. Brick arches are usually built so that units at the crown will be laid in soldier bond or rowlock header bond. Under many circumstances, it is difficult to lay units in soldier bond and still obtain full joints. This is especially true where the curvature of the arch is of short



A unit laid lengthwise in the wall is called a *stretcher*. Standing upright with the narrow side facing out, it is called a *soldier*—with the wide side facing out, a *sailor*. A stretcher unit that is rotated 90° in a wall so that the end is facing out is called a *header*. If the unit is then stood on its edge, it's called a *rowlock*.

A unit whose length is cut in half is called a *bat*. One that is halved in width is called a *soap*, and one that is cut to half height is called a *split*.

Whichever way you turn modular brick, they lay out to a 4-in. module. Turning a brick stretcher crosswise in a two-wythe wall, the header unit is exactly the same width as two wythes of stretcher brick with a $3/8$ " collar joint between. Two header units or three rowlocks are the same length as one stretcher. One soldier course is the same height as three stretcher or header courses, and so on.

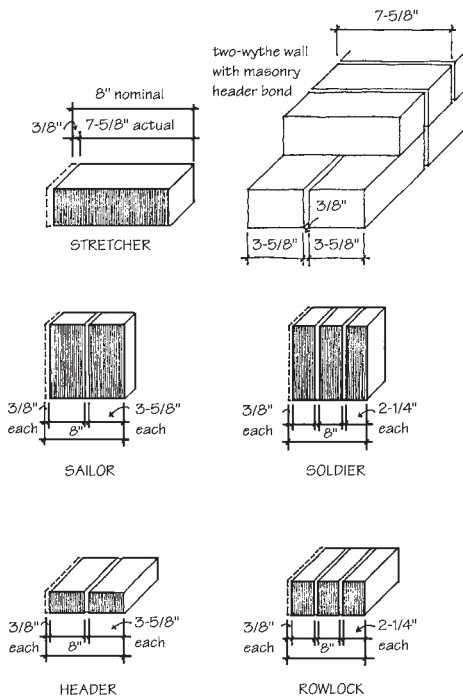


Figure 15-17 Masonry unit orientation and nomenclature. (From Beall and Jaffe, Concrete and Masonry Databook, McGraw-Hill, 2003.)

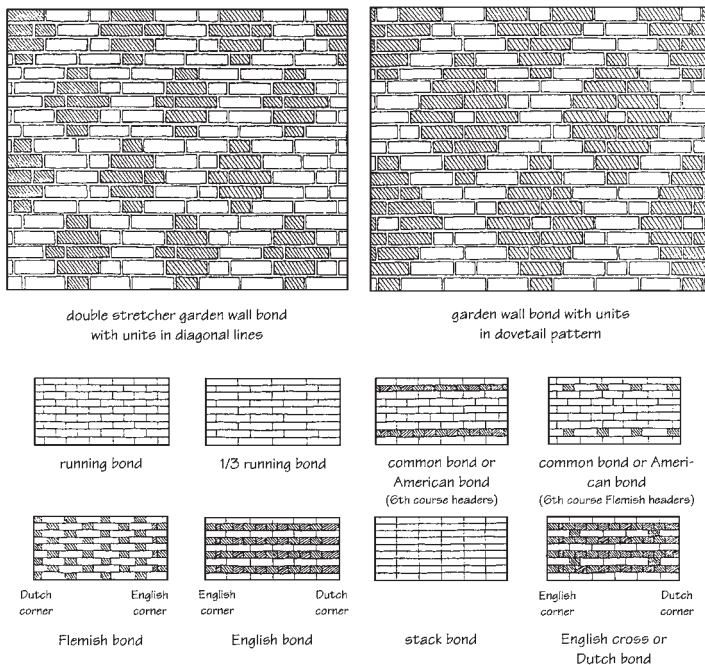


Figure 15-18 Brick masonry pattern bonds.

radius with mortar joints of varying thickness. In such cases, the use of two or more rings of rowlock headers is recommended (see Fig. 15-21). In addition to facilitating better jointing, rowlock headers provide a bond through the wall to strengthen the arch.

Mortar color and joint type can be just as important in determining the appearance of a wall as the selection of a unit type or color, and should be carefully considered in the design of the building. Sample panels at the job site can help in evaluating workmanship and appearance of the finished work, and should always be specified to assure that the desired effect can be achieved.

Variations in aesthetic effect can be achieved by using different types of mortar joints. Two walls with the same brick and the same mortar color can have a completely different appearance depending on the joint treatment used (see Fig. 15-22). Concave or V-tooled joints are most resistant to water

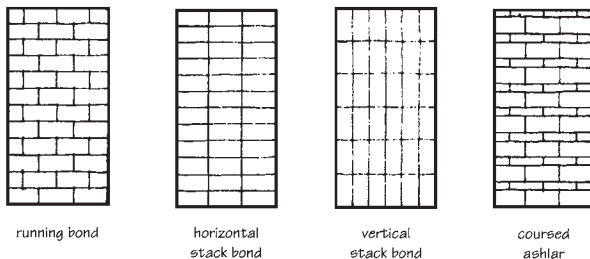


Figure 15-19 Concrete block bond patterns. (From NCMA TEK Bulletin 57.)

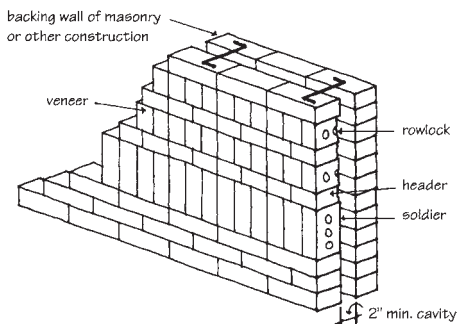


Figure 15-20 Half rowlocks and half headers used in a cavity wall to simulate the appearance of a masonry bonded wall.

penetration and are recommended for use in areas subject to heavy rains and high winds. *Rough-cut* or *flush* joints are used when other finish materials, such as stucco, gypsum board, or textured coatings, are to be applied over the masonry. *Weathered* joints are more difficult to form since they must be formed from below, but some compaction does occur, and the joint sheds water naturally. *Struck* joints are easily cut with a trowel point, but the small ledge created collects water, which may then penetrate the wall. *Raked* joints are made by scraping out a portion of the mortar while it is still soft, using a square-edged tool. Even though the mortar is slightly compacted by this action, raked joints allow more water penetration than concave or V-tooled joints. The cut of the joint does form a shadow, and tends to give the wall a darker appearance. *Weeping* joints leave excess mortar protruding from the joint to give a rustic appearance, but again allow more water pene-

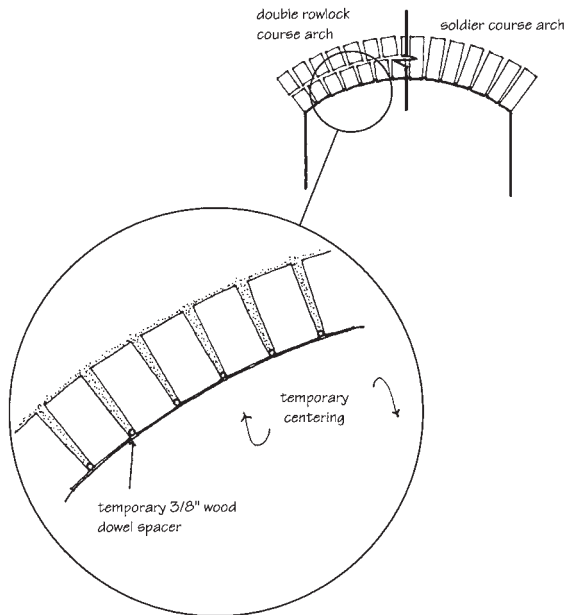


Figure 15-21 Constructing brick arches. (From Beall, *Masonry and Concrete for Residential Construction*, McGraw-Hill Complete Construction Series, 2001.)

tration than concave or V-tooled joints. Other, more specialized effects can be achieved with tools to bead or groove the joint.

The most effective and moisture-resistant joints are the *concave* and *V-shaped* tooled joints. Mortar squeezes out of the joints as the masonry units are set in place, and the excess is struck off with a trowel. After the mortar has become “thumbprint” hard (i.e., when a clear thumbprint can be impressed and the cement paste does not stick to the thumb), joints are finished with a jointing tool slightly wider than the joint itself (see Fig. 15-23). As the mortar hardens, it has a tendency to shrink slightly and separate from the edge of the masonry unit. Proper tooling compresses the mortar against the unit and compacts the surface, making it more dense and more resistant to moisture penetration (see Fig. 15-24). Joint tooling is especially critical in single-wythe walls where there is little or no secondary defense against water penetration. However, full head and bed joints and good mortar bond are equally important to moisture resistance. Other joint treat-



Figure 15-22 Raked horizontal joints in the wall panel on the left give the masonry a darker appearance than the concave tooled joints in the wall panel on the right.

ments may be used in mild to moderate exposures (refer to Chapter 9) *if* the workmanship is good, the bond between units and mortar is complete and intimate, and the flashing and weep-hole system is properly designed and installed.

Horizontal joints should be tooled before vertical joints, using a jointer that is at least 22 in. long and upturned on one end to prevent gouging. Jointers for vertical tooling are small and S-shaped. Although the material most commonly used for these tools is steel, plastic jointers are used to avoid darkening or staining white or light-colored mortars. After the joints have been tooled, mortar burrs or ridges should be trimmed off flush with the face of the unit with a trowel edge, or by rubbing with a burlap bag, a brush, or a piece of carpet.

It is important that the moisture content of the mortar be consistent at the time of tooling, or color variations may create a blotchy appearance in the wall (see Fig. 15-25). Drier mortar tools darker than that with a higher moisture content. Along with time and weather conditions, unit suction affects the rate at which the mortar loses its mixing water. Units that have not been protected from accidental wetting at the construction site will have inconsistent suction, as those at the top and sides of pallets absorb rain or melting snow. When placed in the wall, units with varying suction will cause inconsistent mortar drying rates and inconsistent color in the finished joints. Keeping the units covered will help prevent variations in the color of the tooled mortar joints.

Even with high-quality workmanship, some patching or repair of mortar joints may be expected. In addition, any holes left by nails or line pins must be filled with fresh mortar before tooling. The troweling of mortar into joints after the units are laid is known as *pointing*. It is preferable that pointing and patching be done while the mortar is still fresh and plastic, and



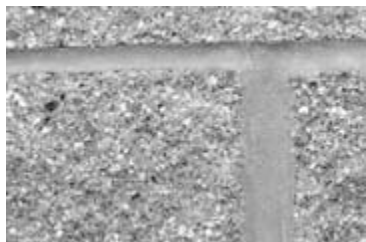
Figure 15-23 Concave tooling when the mortar is “thumbprint hard” should produce joints of uniform color and appearance that are well compacted at the bond line to maximize resistance to water penetration. (Photos courtesy BIA.)

before final tooling of the joints is performed. If, however, the repairs must be made after the mortar has hardened, the joint must be raked or chiseled out to a depth of about $\frac{1}{2}$ in., thoroughly wetted, and repointed with fresh mortar.

15.3.2 Flashing and Weep Holes

Flashing must be installed in continuous runs, with all seams and joints lapped 4 to 6 in. and sealed. Metal flashing laps sealed with a non-hardening butyl tape or caulk can accommodate thermal expansion and contraction while preventing lateral moisture flow. Unsealed lap joints will allow water to flow around the end of the flashing and penetrate the wall (see Fig. 15-26). Inside and outside corners can be fabricated of metal, or preformed rubber corner boots can be used, even with metal flashing systems (see Fig. 15-27). At lateral terminations where the flashing abuts other construction elements, and at terminations on each side of door and window lintels and window sills, flashing must be turned up to form an end dam. Metal flashing can be cut, folded, and soldered or sealed with mastic to form a watertight pan, and flexible flashing can be folded into place. Without end dams, water that collects on the flashing is free to run off the ends and into the wall, or into adjacent door jambs, windows, curtain walls, or other cladding systems (see Fig. 15-28).

Flashing should never be stopped short of the face of the wall, or water may flow around the front edge, under the flashing, and back into the wall (see Fig. 15-29). Metal flashing should be brought out beyond the wall face and turned down to form a drip. A hemmed edge will give the best appearance. Flexible flashing cannot be formed in the same way, but should be extended beyond the face of the wall and later trimmed flush with the joint (see Fig. 15-30). Some designs may call for flexible membrane flashing such as EPDM or rubberized asphalt to be lapped and sealed over the top of a separate metal drip edge (see Fig. 15-31). Two-piece flashing can also be used, even with all-metal flashing systems, to accommodate construction tolerances in the necessary length of the horizontal leg. The vertical leg of the flashing should be turned up 8 in. to form a back dam and be placed in a mortar joint in the backing wythe, in a reglet on concrete walls, or behind the felt or building wrap on stud walls (see Fig. 15-32).



well compacted surface,
tight bond line



rough surface, bond line
separations



rough surface, bond line
separations, voids

Figure 15-24 Good joint tooling is the first line of defense against water penetration, and is especially critical in single-wythe walls.

Weep holes are required in masonry construction at the base course and at all other flashing levels (such as shelf angles, sills, and lintels) so that water that is collected on the flashing may be drained from the wall as quickly and effectively as possible. Weep holes should be spaced 16 to 24 in. on center, depending on the method used:

- Open head joints, large rectangular weep tubes, plastic grid, or vented weep covers at 24 in. on center in brick or 32 in. on center in block (see *Fig. 15-33*).



Figure 15-25 Joints should be tooled at a consistent moisture content because drier mortar tools to a darker color than mortar that is wetter when tooled.



Figure 15-26 Unsealed lap joints allow water to circumvent the flashing.

- Oiled rods, rope, or pins placed 16 in. on center in the head joints and removed before final set of the mortar (see *Fig. 15-34*).
- Cotton sash cord or other suitable wicking material placed 16 in. on center in the head joint (see *Fig. 15-35*).
- Small plastic weep tubes are not recommended because they clog too easily both during and after construction (see *Fig. 15-36*).

To function properly, weep holes must be unobstructed by mortar droppings or other debris. Blocked or missing weep holes can cause saturation of the masonry just above the flashing as moisture is dammed in the wall for longer periods of slow evaporation. Efflorescence, staining, corrosion of steel

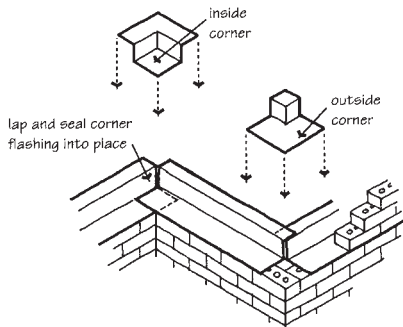


Figure 15-27 Corner flashing can be field or shop fabricated of metal, or prefabricated self-adhering rubberized asphalt flashing boots can be used.

lintels or studs, mold growth, and freeze-thaw damage can result (see Fig. 15-37). Weep hole tubes are most vulnerable to blockage, even when gravel drainage accessory beds are used. Chapter 7 illustrates several proprietary drainage accessory products, all of which are intended to maintain the free flow of moisture to the weep holes. Some are more effective than others, but all are probably more effective than pea gravel in the bottom of the wall cavity (see Fig. 15-38). Use of a drainage accessory, however, does not eliminate the need for proper construction procedures to minimize mortar droppings.

15.3.3 Control and Expansion Joints

Control joints and expansion joints are used to relieve stresses caused by differential movement between materials, and by thermal and moisture movement in the masonry itself (refer to Chapter 9). *The terms control joint and expansion joint are not interchangeable.* The two types of joints are different in both function and configuration.

Control joints are continuous vertical head joints constructed with or without mortar, to accommodate the permanent moisture *shrinkage* that all *concrete masonry* units experience. When shrinkage stresses are sufficient to cause cracks, the cracking will occur at these weakened joints rather than at random locations. Shear keys are used to provide lateral stability against wind loads, and elastomeric sealants are used to provide a watertight seal (see Fig. 15-39). Mortared control joints must be raked out to a depth that will allow placement of a backer rod or bond-breaker tape (to prevent three-sided adhesion) and a sealant joint of the proper width-to-depth ratio. Shrinkage always exceeds expansion in concrete masonry because of the initial moisture loss after manufacture. So even though control joints contain hardened mortar, they can accommodate reversible thermal expansion and contraction because it occurs after the initial curing shrinkage. Joint reinforcement should be stopped on either side of control joints.

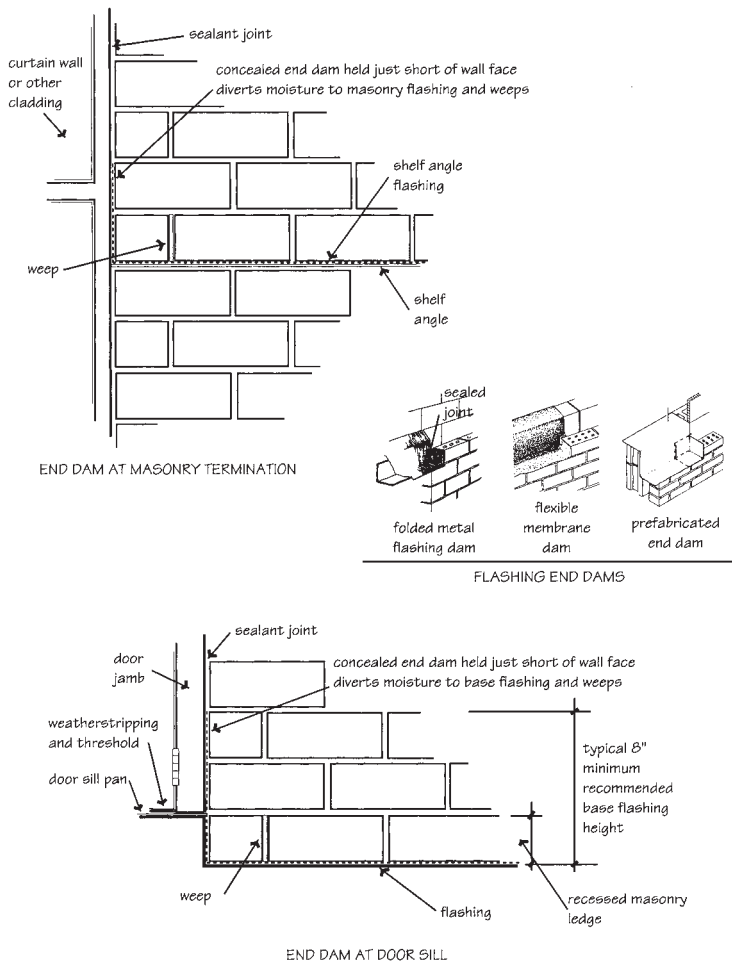


Figure 15-28 Form end dams wherever flashing terminates at windows and doors and against adjacent construction.



Figure 15-29 Flashing that does not extend through the outside wall face can allow moisture to flow around the front edge of the membrane and back into the wall.



Figure 15-30 Trim flexible flashing flush with outside face of wall. (Photo courtesy BIA.)

Expansion joints are used in brick, terra cotta, and structural clay tile construction to accommodate the permanent moisture expansion that all clay masonry products experience as they reabsorb atmospheric moisture after firing. Expansion joints are also used in stone cladding systems to accommodate thermal expansion and contraction, so expansion always exceeds reversible thermal expansion and contraction, but expansion joints cannot contain mortar or other hard materials (see Fig. 15-40). Lateral support is provided by placing an anchor or tie on either side of expansion joints. During construction, plywood strips can be used to prevent mortar from bridging the expansion joint and restricting subsequent movement, but such rigid materials *must* be removed when the masonry construction is complete (see Fig. 15-41). Soft joint filler materials such as neoprene rubber sponge may also be used to keep mortar out of the joint during construction, but may be left in place only if they are sufficiently compressible to allow the expected movement to occur. Joint fillers that are left in place must be set deep enough in the joint to allow room for a backer rod and a sealant joint of the proper depth (refer to Chapter 9). Filler materials should not be used as

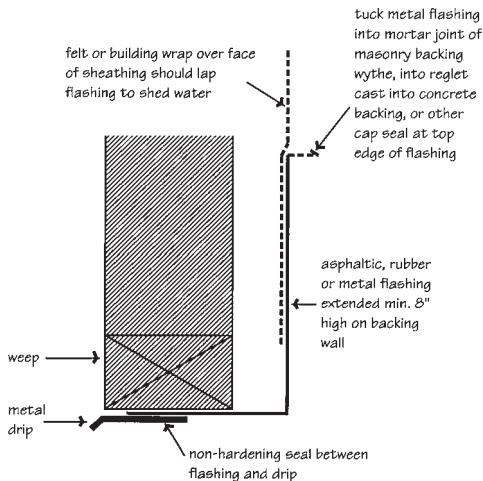


Figure 15-31 Lap flashing over a separate metal edge to form a drip, to avoid ultraviolet exposure, or to accommodate variations in cavity width.

backing for the sealant because of potential problems with compatibility, adhesion, and consistent joint depth-to-width ratios.

In cavity wall construction of brick with block backup, control joints and expansion joints, in the backing and facing wythes, respectively, should occur at approximately the same locations but need not align exactly. Joint reinforcement should not continue across movement joints.

15.3.4 Accessories and Reinforcement

Metal ties, anchors, horizontal joint reinforcement, and steel reinforcing bars are all placed by the mason as the work progresses. Anchors, ties, and joint reinforcement must be corrosion resistant, properly spaced, and placed in the mortar to assure complete encapsulation and good bond. Joint reinforcement anchors and ties are usually laid directly on the units. When the mortar is placed, it surrounds and encapsulates the wire because of irregularities in the wire and unit surfaces. All metals should be protected by a minimum $\frac{5}{16}$ -in. mortar cover at exterior joint faces (see Fig. 15-42).

Vertical reinforcement in a cavity wall is easily placed, and the masonry built up around it. Bar positioners are required at periodic intervals to hold the reinforcing bars in vertical alignment. If horizontal steel is required in the cavity, it is tied to the vertical members or may rest on the spacers at the proper intervals (see Fig. 15-43).

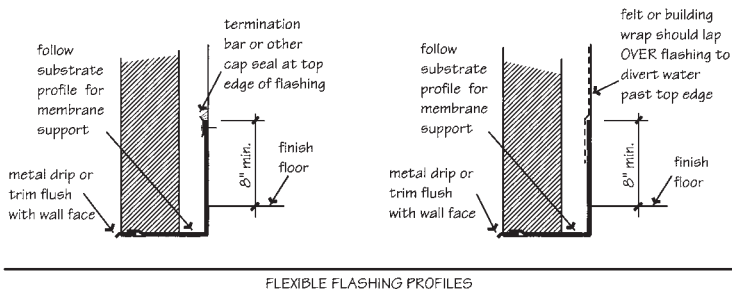
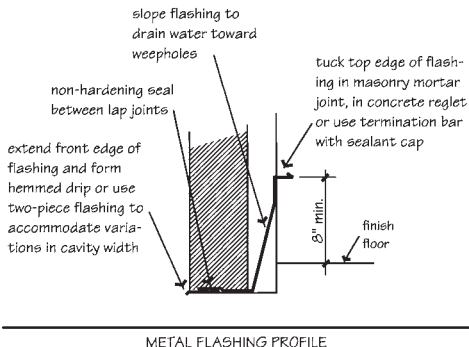


Figure 15-32 The top edge of the flashing should be terminated in such a way that water cannot flow behind it.

For reinforced CMU walls, special open-end units are made so that the block may be placed around the vertical steel rather than threaded over the top of the bar (see Fig. 15-44). Some specially designed blocks have been produced that can accommodate both vertical and horizontal reinforcing without the need for spacers. The proprietary block shown in Fig. 15-44 not only has open ends, but also incorporates notches in the webs for placement of horizontal bars. This type of unit is very economical for grouted, reinforced CMU walls, particularly when the design utilizes wall beams and bond beams requiring large quantities of horizontal steel.

Reinforcing steel in masonry construction is required by code to have certain minimum clearances between bars and cavities so that grout can easily flow around and encapsulate the steel (see Fig. 15-45). Reinforcing

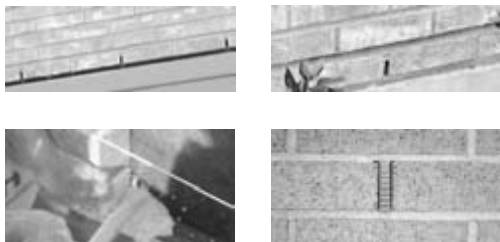


Figure 15-33 Open head joints, large rectangular weep tubes, plastic grid, or vented weep covers should be spaced 24 in. on center in brick masonry or 32 in. on center in concrete block masonry.



Figure 15-34 Oiled rods, ropes, or pins should be spaced 16 in. on center and removed before final set of mortar. (Photo courtesy BIA.)

steel is also required to have minimum distances from the outside face of elements to protect the metal from moisture and from fire exposure (see Fig. 15-46). The MSJC Code prescribes placement tolerances for reinforcing steel as shown in Fig. 15-47. During the course of construction, the mason also places anchorages and cutouts required to fit the work of other trades. These items are furnished and located by others, but incorporated into the wall by the mason. Steel or precast lintels for small openings are also placed by the mason if reinforced masonry lintels are not used in the design. Metal shims used for alignment of steel lintels and shelf angles should be the full height of the vertical angle leg to prevent rotation.

15.3.5 Grouting

In reinforced masonry construction, the open collar joint of a double-wythe wall or the vertical cells of hollow units must be pumped with grout to secure the reinforcing steel and bond it to the masonry.



Figure 15-35 Cotton rope wicks spaced 16 in. on center. (Photos courtesy BIA.)



Figure 15-36 Small plastic weep tubes are not recommended because they clog too easily both during and after construction.



Figure 15-37 Mortar droppings can inhibit the drainage through weeps, causing efflorescence or other moisture damage.

In both brick and CMU work, the importance of keeping the cavity clean has been stressed before, but should be re-emphasized here. Protrusions or fins of mortar which project into the cavity will interfere with proper flow and distribution of the grout, and could prevent complete bonding (see Fig. 15-48). Grout space requirements must be increased to account for the protrusions and for the width of horizontal reinforcing bars



Figure 15-38 Use of a proprietary drainage mat does not eliminate the need for proper construction procedures to minimize mortar droppings.

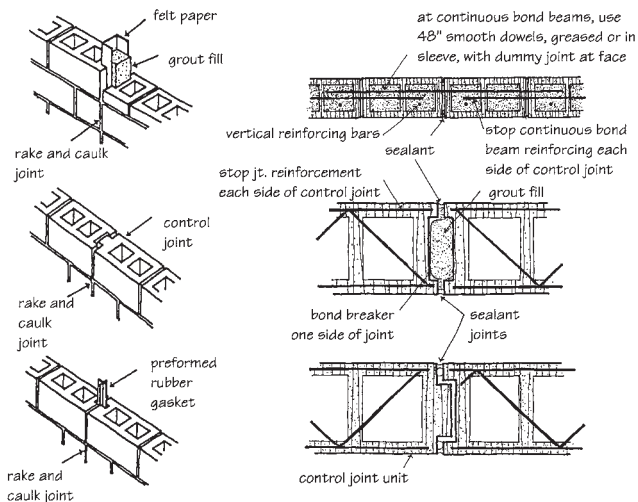


Figure 15-39 CMU control joints.

(see Fig. 15-49). The spacers used to maintain alignment of vertical reinforcing will assure complete coverage of the steel and full embedment in the grout for proper structural performance. If bond beams or isolated in-wall columns are to be poured in a double-wythe wall, material must be placed below and/or to either side of the area to prevent the grout from flowing beyond its intended location. For example, if a bond beam is to be poured in a double-wythe brick wall, expanded metal lath or metal screen

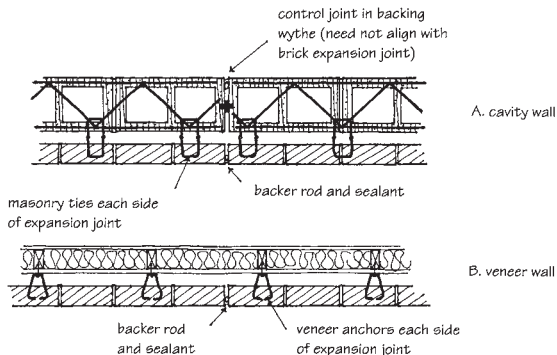


Figure 15-40 Brick masonry expansion joints.



Figure 15-41 Remove boards or other non-compressible fillers used to keep mortar and debris out of expansion joints during construction.

should be placed in the bed joint below to contain the pour (see Fig. 15-50). Grouting of concrete masonry should be performed as soon as possible after the units are placed so that shrinkage cracking at the joints is minimized, and so that the grout bonds properly with the mortar.

The *low-lift method* of grouting a wall is done in maximum 12-in. lifts as the wall is laid up (see Fig. 15-51) and to a maximum pour height of 5 ft (see Fig. 15-52). For double-wythe wall construction, the first wythe is laid up, followed by the second wythe, which is generally left 8 to 12 in. lower. Grout should be well mixed to avoid segregation of materials, and carefully poured to avoid splashing on the top of the brick, since dried grout will prevent proper mortar bond at the succeeding bed joint. At least 15 minutes should elapse between pours to allow the grout to achieve some degree of stiffness before the next layer is added. If grout is poured too quickly, and the mortar joints are fresh, hydrostatic pressure can cause the wall to bulge out

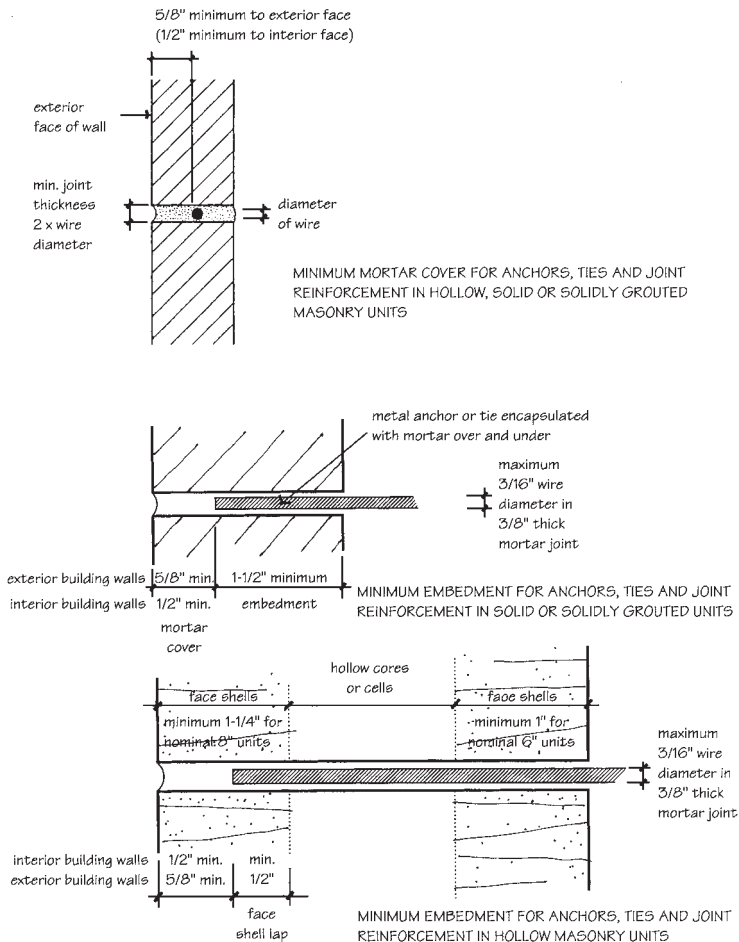


Figure 15-42 Minimum embedment and mortar cover for masonry anchors, ties, and joint reinforcement.

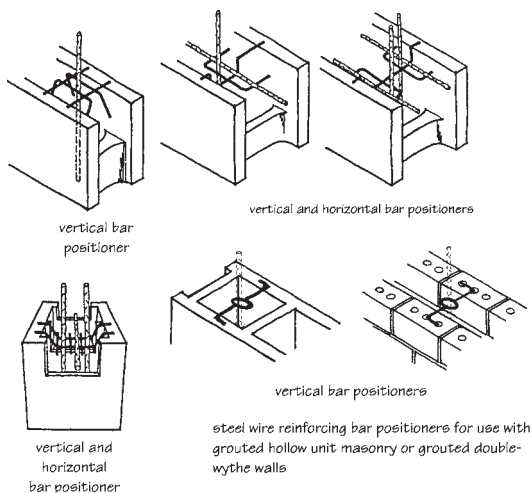


Figure 15-43 Bar positioners for vertical reinforcing steel.

of plumb. A displacement of as little as $\frac{1}{8}$ in. can destroy the bed joint bond, and the work must be torn down and rebuilt. The joint rupture will cause a permanent plane of weakness and cannot be repaired by simply realigning the wall.

Bed joints can also be broken by rotation of the brick from uneven suction. To avoid this, the grout level should be kept at or below the center of the top course during construction. If operations are to be suspended for more than 1 hour, however, it is best to build both wythes to the same level, and pour the grout to within $\frac{3}{4}$ in. of the top of the units to form a key with the next pour. Grout that is in contact with the masonry hardens more rapidly than that in the center of the grout space. It is therefore important that consolidation take place immediately after the pour and before this hardening begins.

Grout must be consolidated by vibration as it is being placed to minimize voids that are left when water from the grout mix is absorbed by the masonry (see Fig. 15-53). Grout consolidation can be accomplished by puddling with a piece of reinforcing bar if the lifts do not exceed 12 in., but for higher lifts, a mechanical vibrator with a $\frac{3}{4}$ - to 1-in.-diameter head must be used. Five to ten minutes after the grout is placed, the vibrator should be inserted into the grout cavity or cores for a few seconds in each location. Within 30 minutes of consolidation, the grout must be reconsolidated to assure proper bond to the units and reinforcement. Reconsolidation prevents separations from developing between the grout and the masonry after shrinkage, settlement, and absorption have occurred.

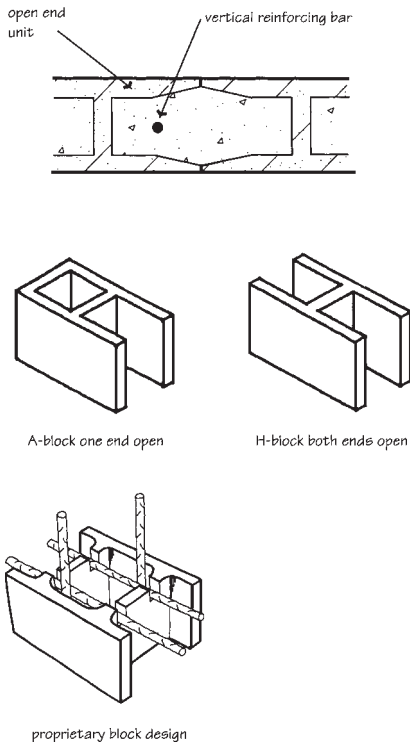
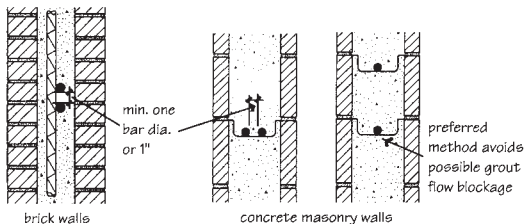


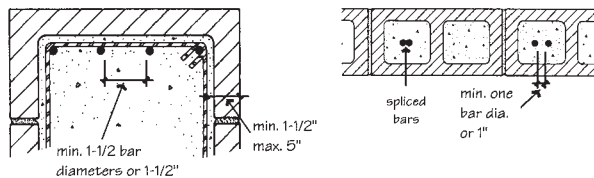
Figure 15-44 Special open-end block designs make it easier to place units around vertical reinforcing steel instead of threading over the top of the bar.

In single-wythe hollow-unit construction, walls are built to a maximum 5-ft height before grout is pumped or poured into the cores. Grout is placed in the cores, and then consolidated to ensure complete filling and solid embedment of steel.

High-lift grouting operations are not performed until the wall is laid up to full story height (see Fig. 15-54). In multi-wythe walls, one wythe is built up not more than 16 in. above the other, and vertical grout barriers are used to contain the grout within a 30-ft length of wall.

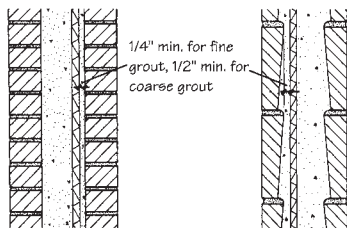


CLEARANCE BETWEEN HORIZONTAL REINFORCING BARS



CLEARANCE BETWEEN VERTICAL BARS IN MASONRY COLUMNS

CLEARANCE BETWEEN VERTICAL REINFORCEMENT IN HOLLOW MASONRY UNIT WALLS



CLEARANCE BETWEEN REINFORCING STEEL AND MASONRY UNITS

Figure 15-45 Code-required minimum clearances for masonry reinforcement. (Drawings from Amrhein, Reinforced Masonry Engineering Handbook, 5th ed.)

Reinforcement Cover for Masonry Structures	
Reinforced Masonry	Minimum Cover (in.) [†]
Masonry exposed to earth or weather	2
No. 6 and larger	1-1/2
No. 5 and smaller	1-1/2
Masonry not exposed to earth or weather	1-1/2

[†] Minimum cover includes thickness of masonry unit.

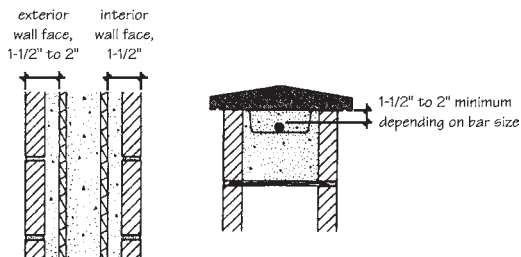


Figure 15-46 Code requirements for minimum masonry and grout cover for reinforcement. (Drawings from *Amrhein, Reinforced Masonry Engineering Handbook, 5th ed.*)

Element	Distance From Centerline of Steel to the Opposite Face of Masonry		
	≤ 8 in.	> 8 in. but ≤ 24 in.	> 24 in.
Walls and Flexural Elements	± 1/2 in.	± 1 in.	± 1-1/4 in.
Walls	For vertical bars, within 2 in. of location along length of wall		

Figure 15-47 MSJC Code placement tolerances for masonry reinforcement.

Cleanouts must be provided at the base of the wall by leaving out every other unit in the bottom course of the section being poured. In single-wythe hollow-unit walls, cleanout openings of at least 3×4 in. are located at the bottom of every core containing dowels or vertical reinforcement, and in at least every second core that will be grouted, but has no steel. In solidly grouted, unreinforced single-wythe walls, every other unit in the bottom course should be left out. Codes generally specify exact cleanout requirements, and should be consulted prior to construction.

A high-pressure air blower is used to remove any debris that may have fallen into the core or cavity. The cleanouts are filled in after inspection of the cavity, but before the grouting begins (see *Fig. 15-55*). The mortar joints

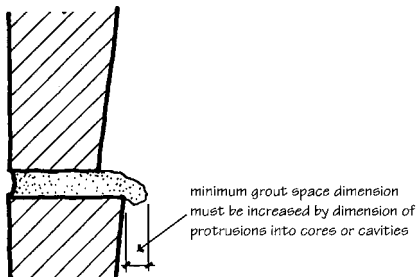


Figure 15-48 Mortar protrusions into the wall cavity or unit cores will inhibit the flow of grout and create voids within the section.

in a wall should be allowed to cure for at least 3 days to gain strength before grouting by the high-lift method. In cold, damp weather, or during periods of heavy rain, curing should be extended to 5 days.

Grout should be placed in a continuous operation with no intermediate horizontal construction joints within a story height. Five-foot maximum lifts are recommended, with 30 to 60 minutes between pours to allow for settlement, shrinkage, and absorption of excess water by the units. In each lift, the top 12 to 24 in. is reconsolidated before or during placement of the next lift. It is critical that the grout consistency be fluid, and that it be consolidated and reconsolidated by mechanical vibration.

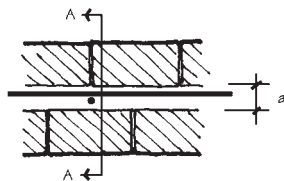
15.3.6 Protections

High-lift grouting requires that walls be temporarily braced until the mortar and grout have fully set. Partially completed walls should also be braced dur-

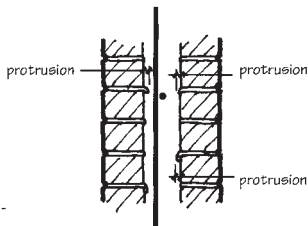
Minimum Grout Space Requirements for ASTM C476 Grout (with tolerance of +3/8" or -1/4")			
Grout Type	Maximum Grout Pour Height (ft.)	Minimum Width of Grout Space Between Wythes of Masonry [§] (in.)	Minimum Grout Space Dimensions for Grouting Cells or Cores of Hollow Units [¶] (in. x in.)
Fine	1	¾	1½ x 2
Fine	5	2	2 x 3
Fine	12	2½	2½ x 3
Fine	24	3	3 x 3
Coarse	1	1½	1½ x 3
Coarse	5	2	2½ x 3
Coarse	12	2½	3 x 3
Coarse	24	3	3 x 4

§ Grout space dimension is the clear dimension between any masonry protrusion and shall be increased by the diameters of the horizontal bars within the cross section of the grout space.

¶ Area of vertical reinforcement not to exceed 6% of the area of the grout space.

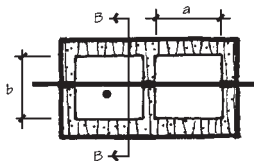


$a >$ minimum grout space dimension plus horizontal bar diameter plus horizontal protrusions



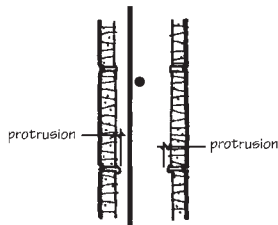
SECTION A-A

GROUT SPACE REQUIREMENTS FOR CAVITY BETWEEN WYTHES OF MASONRY



$a >$ minimum grout space dimension

$b >$ minimum grout space dimension plus horizontal bar diameter plus horizontal protrusions



SECTION B-B

GROUT SPACE REQUIREMENTS FOR CELLS OR CORES OF HOLLOW UNITS

Figure 15-49 Masonry grout space requirements. (From *Masonry Standards Joint Committee, Building Code Requirements for Masonry Structures, ACI 530/ASCE 5/TMS 402.*)

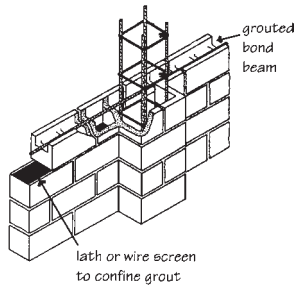


Figure 15-50 Use lath or wire screen to confine grout for bond beams.

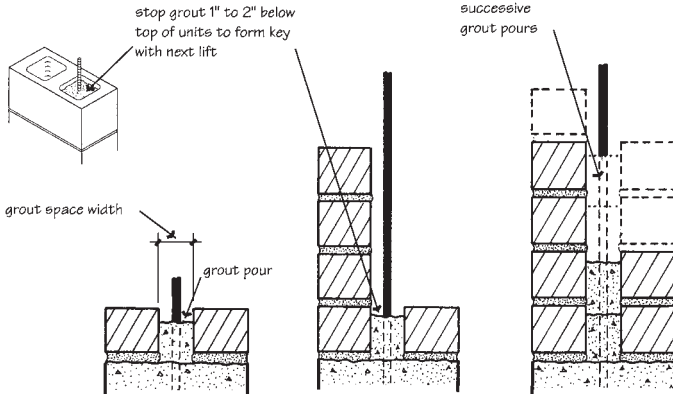


Figure 15-51 For small projects, grout may be placed as the masonry is laid in lifts not to exceed 12 in. in height. (From Informational Guide to Grouting Masonry, *Masonry Institute of America, 1992.*)

ing construction against lateral loads from wind or other forces applied before the mortar has cured, before full design strength is attained, or before permanent supporting construction is completed (see Fig. 15-56). Partially completed structures may be subject to loads that exceed their structural capabilities. Wind pressure, for instance, can create 4 times as much bending stress in a new, free-standing wall as in the wall of a completed building. Fresh masonry with uncured mortar has no tensile strength to resist such lateral forces. Most codes require that new, uncured, unanchored walls be

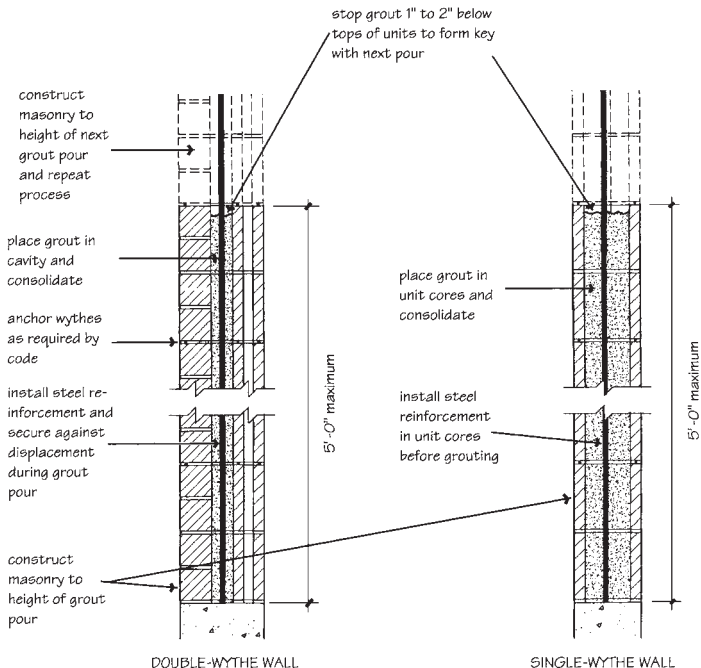


Figure 15-52 Low-lift grout pours may not exceed 5 ft in height. (From *Grouting Masonry, Masonry Construction Guides Section 7-11, International Masonry Institute, 1997.*)

braced against wind pressure. Bracing should be provided until the mortar has cured and the wall has been integrally tied to the structural frame of the building. Bracing should be designed on the basis of wall height and expected wind pressures.

Arches are constructed with temporary shoring or centering to carry the dead load of the material and other applied loads until the arch itself is completed and has gained sufficient strength (see Fig. 15-57). Temporary bracing should never be removed until it is certain that the masonry is capable of carrying all imposed loads. For unreinforced masonry arches, it is generally recommended that centering remain in place for 7 days after the completion of the arch. Where loads are relatively light, or where the majority of the wall load will not be applied until some later date, it may be possible to remove the centering earlier.

GROUT CONSOLIDATION AND RECONSOLIDATION

Grout must be consolidated by vibration to minimize voids that are left when water from the grout mix is absorbed by the masonry. Grout consolidation can be accomplished by puddling with a piece of reinforcing bar if the lifts do not exceed 12 in., but for higher lifts, a mechanical vibrator with a 3/4- to 1-in. diameter head must be used. Five to ten minutes after the grout is placed, the vibrator should be inserted into the grout cavity or cores for a few seconds in each location. Within 30 minutes of consolidation, the grout must be reconsolidated to assure proper bond to the units and reinforcement. Reconsolidation prevents separations from developing between the grout and the masonry after shrinkage, settlement, and absorption have occurred.

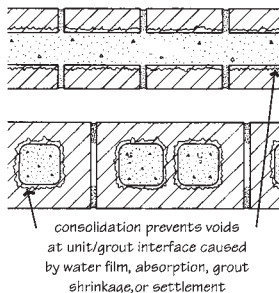


Figure 15-53 Grout must be consolidated and reconsolidated to prevent voids at the masonry interface. (Drawing from *Informational Guide to Grouting Masonry*, Masonry Institute of America, 1992.)

Masonry walls should be covered at the end of each day and when work is not in progress. Excess moisture entering the wall during construction can cause saturation of units, which may take weeks or months to dry out. Such prolonged wetting will take even slightly soluble salts into solution and may result in efflorescence. Prolonged wetting will also prolong cement hydration, producing large amounts of calcium hydroxide, which may also be taken into solution and leached to the surface to cause calcium carbonate stains.

Covers such as water-repellent tarps or heavy plastic sheets should extend a minimum of 2 ft down each side of the wall and be held securely in place. During construction, scaffold planks should also be turned on edge at the end of each day so that rain will not splash mortar droppings or dirt onto the face of the masonry (see *Fig. 15-58*).

High-lift grouting is more efficient for large projects than low-lift grouting. The full height of the pour must be accomplished in a single day, working in lifts that are a maximum of 5 ft. high. A 30 to 60 minute delay between lifts allows time for consolidation and reconsolidation after initial water loss and settlement have occurred. Each lift should be consolidated by mechanical vibration, with the vibrator head inserted completely through the new lift and extending 12 to 24 in. into the previous lift. This will bond the two lifts together without cold joints. Double-wythe walls should cure for 3 days in warm weather or 5 days in cold weather before high-lift grouting. Single-wythe walls should cure 12 to 18 hours.

Grout fluidity is critical in high-lift grouting to assure complete filling of unit cores or wall cavities, and mortar protrusions into the grout space should be limited to a maximum of 1/2 in. Cleanouts at the base of the wall facilitate removal of debris and inspection prior to grouting operations.

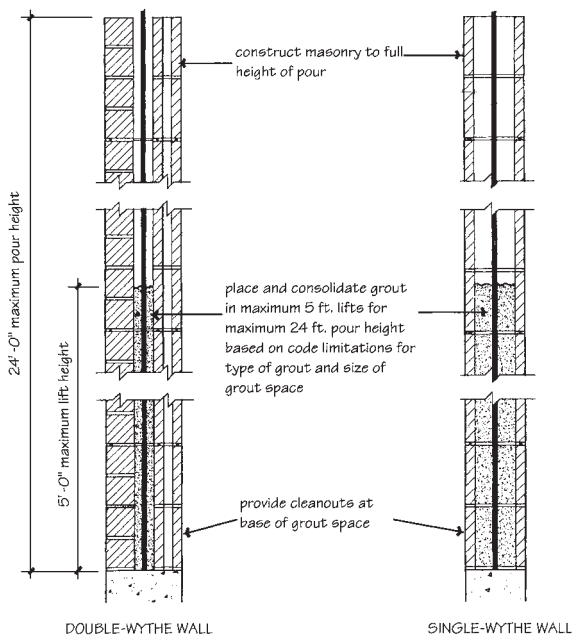


Figure 15-54 High-lift masonry grouting. (From *Grouting Masonry, Masonry Construction Guides Section 7-11*, International Masonry Institute, 1997.)

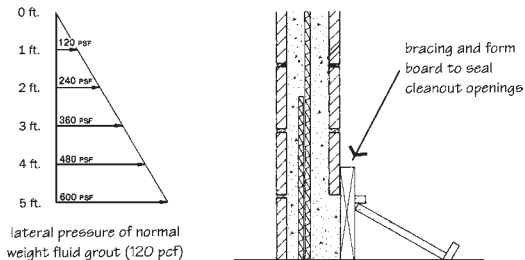


Figure 15-55 Grouting cleanouts and plugs. (From Informational Guide to Grouting Masonry, Masonry Institute of America, 1992.)

15.4 PREFABRICATED MASONRY

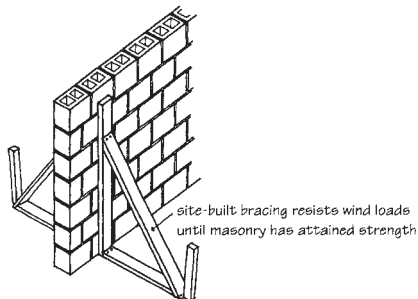
Techniques for prefabricating brick masonry were developed in France, Switzerland, and Denmark during the 1950s, and adopted in the United States in the early 1960s. Reducing on-site labor led the construction industry to use of prefabricated building components, but the masonry industry was a late entrant into the field. The evolution of analytical design methods for masonry, together with improved units and mortars, has made masonry prefabrication a feasible and economical masonry alternative to other systems such as precast concrete (see Fig. 15-59).

Prefabrication methods are used most successfully on brick and stone wall panels and spandrel sections backed by lightweight metal frames. A major requirement for the economic feasibility of preassembly is the repetition of design elements in the structure. Large numbers of identical sections may be mass-produced in environmentally favorable locations, then hoisted into place at the job site for field connections. The need for on-site scaffolding can be eliminated, and panelization allows the construction of complicated shapes without the need for expensive falsework and shoring. Quality control is more easily maintained under factory conditions by automating mortar batching systems and standardizing curing conditions. Prefabrication may also shorten the total construction time, allow earlier occupancy, and benefit the owner by increased income and lower interim financing costs.

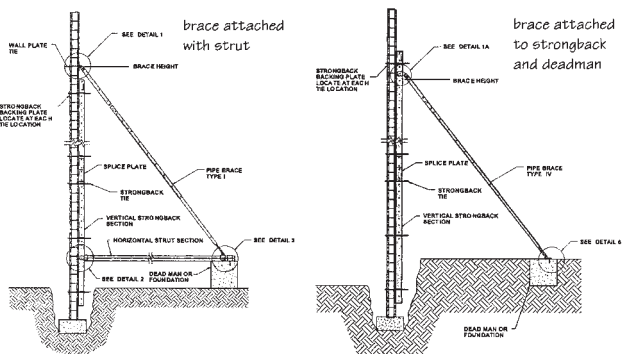
Panel connections for facing materials generally combine the use of shelf angles and welded, bolted, or masonry tie anchors, depending on the type of structural frame used. Allowance must still be made for differential movement between masonry and concrete or steel.

15.5 CONSTRUCTION TOLERANCES

Historically, most construction was done on site and custom fitted. Within generous limits, brick and stone could be laid to fit existing conditions; roof timbers were cut to fit whatever the masons built; and hand-made doors and windows could be made to accommodate the peculiarities of any opening. Today we have metals that are fabricated at the mill, stone that is cut and dressed at the quarry, and concrete that is cast before erection. These prefabricated components are not easily customized on the job, and they must be fitted to site-built frames. Suddenly construction tolerances become very important in ensuring that the puzzle pieces fit together with



(From NCMA TEK, Bulletin 72.)



(From Dur-O-Wall Technical Bulletin 99-2, 1999)

Figure 15-56 Examples of site-built and proprietary masonry bracing systems.

reasonable accuracy—puzzle pieces that may come from a dozen different manufacturers in a half-dozen competing industries.

Little is exact in the manufacturing, fabrication, and construction of buildings and building components. Tolerances allow for the realities of fit and misfit of the various parts as they come together in the field and ensure proper technical function such as structural safety, joint performance, secure anchorage, moisture resistance, and acceptable appearance. Webster defines tolerance as "the allowable deviation from a standard, especially the range of variation permitted in maintaining a specified dimension."

Each construction trade or industry develops its own standards for acceptable tolerances based on economic considerations of what is reasonable

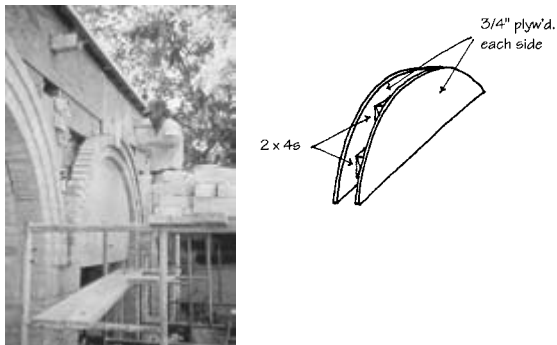


Figure 15-57 Arches require temporary support until the masonry attains strength.



Figure 15-58 Turn scaffold boards on edge at the end of the day to avoid splashing mortar droppings or dirt onto the face of the wall.

and cost effective. Few, if any, construction tolerances are based on hard data or engineering analysis. There has also never been any coordination among various industry groups even though steel and concrete are used together, masonry is attached to or supports both, windows must fit into openings in all three, and sealants are expected to fill all the gaps left between adjacent components.

Different materials and systems, because of the nature of their physical properties and manufacturing methods, have greater or lesser relative allowances for the manufacture or fabrication of components and the field assembly of parts. Masonry includes a variety of materials and unit types, each of which has its own set of tolerances.



Figure 15-59 Lifting a prefabricated masonry panel into place.



Type FBS

for traditional
or contemporary
architectural styles



Type FBX

for crisp, linear,
contemporary styles
of architecture



Type FBA

for rustic styles
of architecture

Figure 15-60 Type FBS, FBX, and FBA have the same quality but differ in appearance for variations in architectural style.

15.5.1 Masonry Size Tolerances

Allowances for the variation in sizes of face brick are covered in ASTM C216. Face brick tolerances are divided into Type FBX and Type FBS. The quality of the units is the same, but Type FBX is required to have tighter size tolerances so that when a designer wishes to create a crisp, linear appearance with, for example, a stack bond, the units and mortar joint variations are kept to a minimum (see Fig. 15-60). Type FBS bricks are more popular for both commercial and residential masonry using running bond and other patterns.

Type FBA bricks are not governed by size tolerances because they are supposed to vary significantly from one unit to the next so that they often look like rough, hand-molded brick. Type FBA bricks are very popular for residential masonry and for projects in historic areas.

Glazed clay masonry units are the most precisely sized masonry products, and are often used to provide easily cleanable surfaces in hospitals and food handling or preparation areas. Since mortar absorbs stains, odors, and bacteria more easily than the glazed unit surface, joint widths must be kept to a minimum, which means that unit sizes must be closely controlled.

Concrete block dimensional variations are covered in ASTM C90 and C129 for loadbearing and non-loadbearing units, respectively. For both types, the standards permit a maximum size variation of $\pm 1/8$ in. from the specified standard dimensions (defined as the “manufacturer’s designated dimensions”).

Although there are no industry-wide standards for dimensional variation of cut and dressed limestone, the Indiana Limestone Institute publishes dimensional tolerances for several different types of finishes (refer to Chapter 5). For granite, the National Building Granite Quarries Association publishes recommended tolerances (refer to Chapter 5). For marble, the Marble Institute of America recommends fabrication tolerances based on the thickness of the panels (refer to Chapter 5). For thin stone curtain walls constructed with sealant joints instead of mortar, dimensional variations are critical to the proper performance of the sealant.

15.5.2 Mortar Joints

Unit masonry size tolerances are accommodated by varying the thickness of the mortar joints. Modular units are designed to be laid with standard $3/8$ -in. joints. The Masonry Standards Joint Committee (MSJC) *Specifications for Masonry Structures* (ACI 530.1/ASCE 6/TMS 602) sets allowable variation in joint thickness based on the structural performance of the masonry (Fig. 15-61).

Aesthetic rather than structural requirements govern tolerances for non-loadbearing masonry veneers. These tolerances will vary according to the type of units specified and the dexterity and skill of the mason. For example, Type FBX brick can be laid with the most uniform joint thickness because the unit size tolerances are very tight. This characteristic lends itself to stack bond patterns where alignment of the head joints is critical to appearance. Usually, all of the units in a shipment are either over- or undersized, but not both, so the *range* of variation will be smaller and the joint width more consistent. Type FBA brick will require considerable variation in joint thickness because of the greater unit size variations, but this is part of the charm and the reason for the popularity of this brick type.

15.5.3 Sealant Joints

The proper extension and compression of sealants and the performance of sealant joints in maintaining a weather seal are dependent on correct joint

Joint	Allowable Tolerance (in.)
Bed joint	$\pm 1/8$
Head joint	$- 1/4$ to $+ 3/8$
Collar joint	$- 1/4$ to $+ 3/8$

Figure 15-61 Field tolerances permitted by code for masonry mortar joints.

size and shape. Stone panel size tolerances are accommodated by variations in the width of the sealant joints, and expansion and control joints in unit masonry construction are affected by unit size tolerances. ASTM C1472, *Guide for Calculating Movement and Other Effects When Establishing Sealant Joint Width*, contains a complete set of tables for calculating sealant joint sizes. Once you have calculated combined thermal and moisture movement and added a factor of safety for construction tolerances, you can adjust joint size to change joint spacing, or adjust joint spacing to change joint size. The fewer joints you provide in a building facade, the wider they must be to equal or exceed the total calculated movement. The more joints you provide, the narrower they may be—up to a point.

Elastomeric sealants require a minimum joint width of $\frac{1}{4}$ in. for proper extension and compression. While $\frac{1}{4}$ -in. joints are achievable in some types of stone panel construction, allowable tolerances in masonry unit and joint sizes make narrow joints impractical to achieve in the field. A more realistic minimum for sealant joints in unit masonry construction is $\frac{3}{8}$ in. to match the width of the mortar joints.

15.5.4 Connections

Structural frame tolerances are based on structural performance, accidental eccentricities, and member-to-member connection methods. Tolerances for cladding such as masonry veneers are based on stability, method of anchorage, and aesthetic perceptions. Allowable tolerances for concrete and steel structural frames are much greater than for the masonry panels, curtain walls, or veneers attached to them.

Allowable construction tolerances are much greater for concealed concrete and steel structural frames than for exposed cladding systems such as masonry veneer. *Figure 15-62* shows the differences in out-of-plumb tolerances for steel frame, concrete frame, and brick veneer. Where exposed veneer is permitted only $\frac{1}{2}$ -in. latitude in either direction, the frames to which it must be connected may vary 2 to 4 times that much. Although the cast-in-place concrete tolerances shown are much more restrictive than those for steel, the few field studies that have been done indicate that the steel tolerances are more realistic in their relationship to actual field construction (see *Fig. 15-63*). Conflicts between structural frame and masonry veneer tolerances affect anchor embedment, support at shelf angles, and flashing details.

When a masonry veneer or curtain wall is attached to a structural frame that is alternately recessed or projected, the adjustments necessary to maintain a plumb line across the facade must be taken up in the anchorages. Different anchor lengths, however, create variable conditions of stiffness, deflection, and load transfer across a building elevation or throughout its height. Varying clearances between the edge of a slab or beam and the back of a curtain wall or veneer also affect the size and placement of thermal insulation, sprayed fireproofing, and fire-safing insulation.

A steel shelf angle with a 5-in. horizontal leg is usually adequate to span a 2-in. cavity width and support a single wythe of 4-in. modular brick veneer. If vertical and/or lateral displacement of the slab or beam to which the shelf angle is attached causes misalignment of the veneer surface, extreme measures are sometimes taken in an attempt to maintain the veneer alignment within its tolerances (see *Fig. 15-64*). Some contractors have been known to cut the brick or the shelf angle leg, or even to chip back

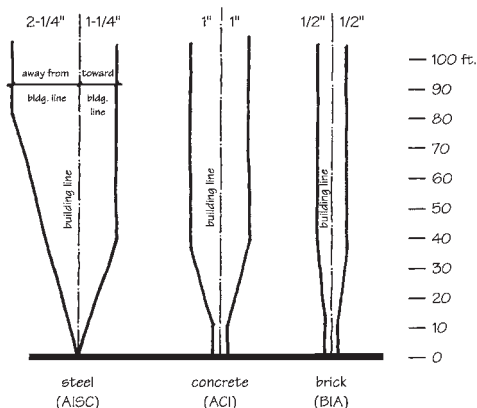
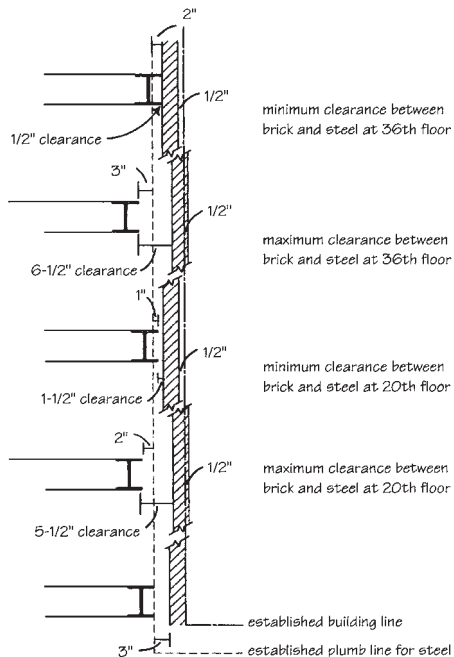


Figure 15-62 Erection tolerances for steel and concrete structural frames compared to placement tolerances for brick veneer.

the face of structural concrete members so far as to expose the reinforcing steel. Such drastic field alterations can sometimes threaten the safety of the building.

Narrowing or eliminating the open cavity behind the veneer jeopardizes proper wall drainage. When the cavity is wider than planned, longer anchors are required to achieve proper embedment in the mortar joints, and shelf angles may be too short to provide adequate support. Shelf angles that are too long may rotate, causing eccentric loading on the masonry courses below and spalling of the unit faces. Increasing the angle thickness to compensate for rotation will create differential stiffness and deflection conditions at random locations in the facade. To accommodate minor field adjustments, specify:

- Bolted rather than welded connections for steel shelf angles, with slotted holes for field adjustments and wedge inserts at points of attachment to concrete frames (refer to Chapter 10)
- That the contractor provide a variety of anchor lengths as necessary to accommodate construction tolerances and provide minimum $\frac{5}{8}$ -in. mortar cover on outside wall face and minimum $1\frac{1}{2}$ -in. embedment in solid masonry units, or minimum $\frac{1}{2}$ -in. embedment into face shell of hollow units
- Two-piece flashing to accommodate varying cavity widths
- Horseshoe shims that are the full height of the vertical leg of the shelf angle and of plastic or a compatible metal, for shimming the angle up to a maximum of 1 in.

**NOTE:**

Variations are for frame erection tolerances only and do not include individual member fabrication tolerances or erection tolerances.

Figure 15-63 Variations between brick veneer and steel structural frame tolerances can be extreme. (Adapted from *Laska, Masonry and Steel Detailing Manual, 1993.*)

15.5.5 Grout and Reinforcement

For reinforced masonry, tolerances are allowed for the placement of the steel bars (refer to *Fig. 15-47*) and the size of the grout spaces (refer to *Fig. 15-49*). The most important thing is to assure complete embedment of the steel within the grout so that full strength is developed. To assure that the reinforcement is not displaced during the grouting operation, specify reinforcing bar spacers or special units that hold the steel in place.

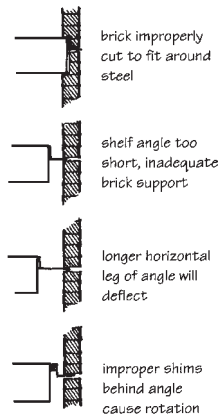


Figure 15-64 Masonry is often altered to accommodate variations in structural frame.

15.6 COLD WEATHER CONSTRUCTION

Cold weather causes special problems in masonry construction. Even though sufficient water may be present, cement hydration and strength development in mortar and grout will stop at temperatures below 40°F. Construction may continue during cold weather, however, if the mortar and grout ingredients are heated and the masonry units and structure are protected during the initial hours after placement. As temperatures drop, additional protective measures are required.

Mortar and grout mixed using cold but unfrozen ingredients have different plastic properties from those mixed under normal conditions. For a given consistency, the mix will contain less water, will exhibit longer setting and hardening times, and will have higher air content and lower early strength. Heating the ingredients prior to mixing, however, will produce mortar with performance characteristics identical to those mixed in a more moderate ambient temperature range. Frozen mortar assumes the outward appearance of being hardened, but it is not actually cured and will not develop full design strength or complete bond until it is thawed and liquid water is again available for hydration. Frozen mortar is easily scratched from joints, has a crow's-foot pattern on the surface of tooled joints, and may flake at the surface.

Cement hydration will resume only when the temperature of the mortar or grout is raised above 40°F and its liquid moisture content exceeds 75%. When these conditions are maintained, ultimate strength development and bond will be the same as those attained under moderate conditions.

The rapidity with which masonry freezes is influenced by the severity of ambient temperature and wind, the temperature and absorption characteristics of the units, the temperature of reinforcing steel and metal accessories, and the temperature of the mix itself at the time of placement.

The water content of mortar and grout significantly affects their freezing characteristics. Wet mixes experience more freezing expansion than drier

ones, and expansion increases as the water content increases. During freezing weather, low-moisture-content mixes and/or high-suction units are desirable, but mortar and grout consistency must maintain good workability and flow so that surface bond is maximized.

Cold masonry units exhibit all the performance characteristics of heated units except that volume is smaller and the potential for thermal expansion within the wall is greater. Wet, frozen units show decreased moisture absorption. Preheated units, on the other hand, will withdraw more water from the mortar because of the absorptive characteristics of a cooling body, but if they are too wet, may still have inadequate absorption. Highly absorptive units, by withdrawing water from the mortar, will increase bond and lower the moisture content, decreasing the potential disruptive expansion that might occur with initial freezing. Units that are dry, but excessively cold, will also withdraw heat from the mortar and increase the rate of freezing.

During cold weather construction, it may be desirable to use a Type III, high-early-strength portland cement because of the greater protection it will provide the mortar. So-called antifreeze additives are not recommended. If used in quantities that will significantly lower the freezing point of the mortar, these additives will rapidly decrease compressive and bond strength. Accelerators that hasten the hydration process are more widely used, but may also have damaging side effects. Calcium chloride is the major ingredient in proprietary set accelerators, and although it is effective, it has a highly corrosive effect on metal reinforcement and accessories. High salt contents of accelerating admixtures may also contribute to efflorescence and cause spalling of the units. In general, the use of set accelerators is not recommended, but when used, such admixtures should be limited to those containing non-chloride ingredients.

Masonry materials should be stored and protected at the job site to prevent damage from wet, cold, or freezing weather. Packaged materials and masonry units should be stored elevated to prevent moisture migration from the ground, and covered to protect the sides and tops. Consideration should be given to the method of stockpiling sand to permit heating of the materials if required.

As the temperature falls, the number of different materials which require heating will increase. Mixing water is easily heated. If none of the other materials are frozen, mixing water may be the only ingredient requiring artificial heat. It should be warmed sufficiently to produce mortar and grout temperatures between 40 and 70°F at the time of placement. Water temperatures above 180°F can cause cement to flash set, so sand and water should be mixed first to moderate high temperatures before the cement is added. Masonry sand, which contains a certain amount of moisture, should be thawed if frozen to remove ice. Sand should be warmed slowly to avoid scorching, and care should be taken to avoid contamination of the material from the fuel source. Dry masonry units should be heated if necessary to a temperature above 20°F at the time of use. Wet, frozen masonry units must be thawed without overheating.

The degree of protection against severe weather which is provided for the work area is an economic balance between mason productivity and cost of the protection. Protective apparatus may range from a simple windbreak to an elaborate heated enclosure. Each job must be evaluated individually to determine needs and cost benefits, but some general rules do apply.

Characteristics such as strength, durability, flexibility, transparency, fire resistance, and ease of installation should be considered when selecting

protective materials. Canvas, vinyl, and polyethylene coverings are often used. In most instances, a windbreak or unheated enclosure will reduce the chill factor sufficiently to provide the degree of protection required. Precautions must also be taken to safeguard workers against injury, and enclosures must be adequate to resist wind, snow, and uplift loads. The MSJC Code requires cold weather protection measures during construction when the ambient temperature is below 40°F. The table in *Fig. 15-65* summarizes heating and protection requirements for various work temperatures.

15.7 HOT WEATHER CONSTRUCTION

Hot weather conditions also pose special concerns for masonry construction (see table in *Fig. 15-66*). High temperatures, low humidity, and wind can adversely affect performance of the masonry. Rapid evaporation and the high suction of hot, dry units can quickly reduce the water content of mortar and grout mixes so that cement hydration actually stops.

When ambient temperatures are above 100°F, or above 90°F with wind velocities greater than 8 mph, the MSJC Code requires that protective measures be taken to assure continued hydration, strength development, and maximum bond. Whenever possible, materials should be stored in a shaded location, and aggregate stockpiles covered with black plastic sheets to retard moisture evaporation. High-suction brick can be wetted to reduce initial absorption, and metal accessories such as reinforcing steel, anchors and ties, mixers, mortar boards, and wheelbarrows can be kept cool by spraying with water.

MSJC Cold Weather Construction Requirements		
Temperature	Action Required	
During Construction		
Ambient Temperature	32 to 40°F or When temperature of masonry units is less than 40°F	Do not lay glass unit masonry. Do not lay units that have a temperature below 20°F. Remove visible ice on units before laying. Heat mortar sand or mixing water to produce mortar temperature between 40°F and 120°F at time of mixing. Maintain mortar above freezing until used in masonry.
	20 to 25°F	Perform actions required when ambient temperature is 32 to 40°F. Provide heat sources on both sides of the masonry. When wind velocity exceeds 15 mph, install wind breaks.
	Less than 20°F	Perform actions required when ambient temperature is 32 to 40°F. Enclose masonry under construction. Provide supplementary heat to maintain temperature within enclosure above 32°F.
For 24 Hours After Construction		
Mean Daily Temperature	32 to 40°F	Cover completed masonry with weather-resistive membrane to protect from rain and snow.
	25 to 32°F	Completely cover completed masonry with weather-resistive membrane.
	20 to 25°F	Completely cover completed masonry with insulating blankets or equal protection.
	Less than 20°F	Enclose masonry. Provide supplementary heat to maintain temperature of masonry within enclosure above 32°F.
For 48 Hours After Construction		
All	Maintain temperature of glass unit masonry above 40°F.	

Figure 15-65 Cold weather masonry construction. (From *Masonry Standards Joint Committee*, Specification for Masonry Structures, *ACI 530.1/ASCE 6/TMS 602*.)

MSJC Hot Weather Construction Requirements	
Temperature	Action Required
Preparation	
Ambient temperature above 100°F, or 90°F with wind velocity greater than 8 mph	Maintain sand piles in a damp, loose condition. Provide necessary conditions and equipment to produce mortar having a temperature below 120°F.
Ambient temperature above 115°F, or 105°F with wind velocity greater than 8 mph	Maintain sand piles in a damp, loose condition. Provide necessary conditions and equipment to produce mortar having a temperature below 120°F. Shade materials and mixing equipment from direct sunlight.
During Construction	
Ambient temperature above 100°F, or 90°F with wind velocity greater than 8 mph	Maintain temperature of mortar and grout below 120°F. Flush mixer, mortar transport container, and mortar boards with cool water before they come into contact with mortar ingredients or mortar. Maintain mortar consistency by retempering with cool water. Use mortar within 2 hrs. of initial mixing.
Ambient temperature above 115°F, or 105°F with wind velocity greater than 8 mph	Maintain temperature of mortar and grout below 120°F. Flush mixer, mortar transport container, and mortar boards with cool water before they come into contact with mortar ingredients or mortar. Maintain mortar consistency by retempering with cool water. Use mortar within 2 hrs. of initial mixing. Use cool mixing water for mortar and grout. Ice is permitted in the mixing water prior to use. Do not permit ice in the mixing water when added to the other mortar ingredients or grout materials.
Protection	
Mean daily temperature above 100°F or 90°F with wind velocity greater than 8 mph	Fog spray all newly constructed masonry until damp, at least three times a day until the masonry is 3 days old.

Figure 15-66 Hot weather masonry construction. (From *Masonry Standards Joint Committee, Specification for Masonry Structures, ACI 530.1/ASCE 6/TMS 602.*)

Additional mixing water may be needed in mortar and grout, and additional lime will increase water retentivity (refer to Chapter 6). Increasing the cement content in the mix accelerates early strength gain and maximizes hydration before evaporative water loss. Adding ice to the mixing water can also lower the temperature of the mortar and grout and slow evaporation. Water that is too hot can cause the cement to flash set. Approved set-retarding or water-reducing admixtures may also be used. Retempering should be limited to the first 2 hours after mixing. Mortar beds should not be spread more than 4 ft ahead of the masonry, and units should be set within 1 minute of spreading the mortar.

Sun shades and wind screens can modify the effects of hot, dry weather, but consideration should also be given to scheduling work during the cooler parts of the day.

15.8 MOIST CURING

Cement hydration cannot occur if the temperature of the mortar or grout is below 40°F or if the internal moisture content of the mix is less than 75%. Both hot and cold weather can produce conditions that cause hydration to stop before curing is complete. These *dryouts* occur most frequently in concrete masonry construction and under winter conditions, but may also occur in brick construction and in hot, dry weather. Dryouts are reactivated by higher temperatures and the subsequent introduction of natural

rainwater, but pending these actions, construction is temporarily limited in compressive strength, bond, and weather resistance.

Moist curing methods similar to those used in concrete construction can help prevent masonry dryouts. Periodically wetting the finished masonry with a fine water spray for several days will usually assure that adequate moisture is available for curing, strength development, and good bond. Covering the walls with polyethylene sheets will also retard evaporation and create a greenhouse effect that aids in moist curing. Extreme winter conditions may also require the application of heat inside these enclosures to maintain minimum temperatures. Even concrete masonry can be moist-cured after the units are incorporated into the construction, because the restraining conditions of the joint reinforcement and surrounding construction minimize the effects of moisture shrinkage in the units.

This page intentionally left blank.

16

MASONRY CLEANING AND RESTORATION

New masonry construction should be cleaned after completion to remove mortar smears and construction-related stains. Periodically throughout its life, the masonry may require additional cleaning if heavy industrial or urban pollutants discolor the surface. Cleaning may also become a diagnostic tool in the repair of structures whose surface defects may be obscured by soil or grime. But cleaning should always be evaluated for necessity and appropriateness, and any cleaning method selected should always be the gentlest possible.

16.1 CONSTRUCTION CLEANING

Cleaning new brick and concrete masonry is easiest if some simple protective measures are taken during construction. But even with protections in place, some mortar smears and splatters will have to be cleaned after the work is complete.

The finished appearance of masonry walls depends to a great extent on the attention given to the surfaces during construction and during the cleaning process. Care should always be taken to prevent mortar smears or splatters on the face of the wall, but if such stains do occur, daily cleaning can help prevent permanent discoloration. Excess mortar and dust can be brushed from the surface easily when the work is still fresh. For brick walls, a brush of medium-soft bristle is preferable. Any motions that rub or press mortar particles into the unit face should be avoided. On concrete block walls, mortar droppings are easier to remove after they have dried.

16.1.1 Protections

Other precautions that may be taken during construction include (1) protecting the base of the wall from rain-splashed mud or mortar droppings by using straw, sand, sawdust, or plastic sheeting spread out on the ground and

up the wall surface; (2) turning scaffold boards on edge at the end of the day to prevent rain from splashing mortar or dirt directly onto the wall; (3) covering the tops of unfinished walls at the end of the day to prevent saturation or contamination from rain; and (4) protecting masonry units and packaged mortar ingredients from groundwater or rainwater contamination by storing off the ground, protected with waterproof coverings.

16.1.2 Cleaning Methods

The cleaning process itself can be a source of staining if chemical or detergent cleansing solutions are improperly used, or if windows, doors, and trim are not properly protected from possible corrosive effects. New masonry may be cleaned by bucket-and-brush hand scrubbing with water, detergent, muriatic acid solution, or proprietary cleaning compounds. Cleaning should be scheduled as late as possible in the construction, and the mortar must be thoroughly set and cured. However, long periods of time should not elapse between completion of the masonry and the actual cleaning, because mortar smears and splatters will cure on the wall and become very difficult to remove. Most surfaces should be thoroughly saturated with water before beginning (saturated masonry will not absorb dissolved mortar particles). Confine work to small areas that can be rinsed before they dry. Environmental conditions will affect the drying time and reaction rate of acid solutions, and ideally the cleaning crew should be just ahead of the sunshine to avoid rapid evaporation. Walls should be cleaned only on dry days.

Detergent solutions will remove mud, dirt, and soil accumulations. One-half cup dry measure of trisodium phosphate and $\frac{1}{2}$ cup dry measure of laundry detergent dissolved in 1 gal of water are recommended. *Acid cleaners* must be carefully selected and controlled to avoid both injury and damage. Hydrochloric acid dissolves mortar particles, and should be used carefully in a diluted state. Hydrochloric acid should be mixed with at least 9 parts clean water in a nonmetallic container, and metal tools or brushes should not be used. Acid solutions can cause green vanadium or brown manganese stains on some clay masonry, and should not be used on light-colored, brown, black, or gray brick that contains manganese coloring agents. *Proprietary cleaning compounds* should be carefully selected for compatibility with the masonry material, and the manufacturer's recommended procedures and dilution instructions should be followed.

Some contractors use *pressurized water* or *steam* cleaning combined with detergents or cleaning compounds. If the wall is not thoroughly saturated before beginning, high-pressure application can drive the cleaning solutions into the masonry, where they may become the source of future staining problems. High-pressure washing can also damage soft brick and mortar and accelerate deterioration. *Abrasive sandblasting* should not be used to clean masonry.

All cleaning methods should be tested on a small, inconspicuous area to determine both the effect and the effectiveness of the process. For cleaning new masonry, the BIA has established guidelines for the selection of methods depending on the type of brick used (see Fig. 16-1). ASTM E1857, *Guide for Selection of Cleaning Techniques for Masonry, Concrete, and Stucco Surfaces* provides a protocol for identification and characterization of substrates, identification of soiling and staining, selection criteria, cleaning techniques, testing, and evaluation for existing buildings, but does not apply specifically to new construction.

Brick Category	Cleaning Method	Remarks
Red and red flashed	<ul style="list-style-type: none"> • Bucket and brush hand cleaning • High-pressure water • Sandblasting 	<ul style="list-style-type: none"> • Hydrochloric (muriatic) acid solutions, proprietary compounds, and emulsifying agents may be used. • <i>Smooth texture:</i> Mortar stains and smears are generally easier to remove; less surface area exposed; easier to presoak and rinse; unbroken surface, thus more likely to display poor rinsing; acid staining, poor removal of mortar smears. • <i>Rough texture:</i> Mortar and dirt tend to penetrate deep into textures; additional area for water and acid absorption; essential to use pressurized water during rinsing.
Red, heavy sand finish	<ul style="list-style-type: none"> • Bucket and brush hand cleaning • High-pressure water 	<ul style="list-style-type: none"> • Clean with plain water and scrub brush, or <i>lightly</i> applied high-pressure and plain water. Excessive mortar stains may require use of cleaning solution. <i>Sandblasting is not recommended.</i>
Light-colored units (white, tan, buff), gray, pink, specks, brown and black	<ul style="list-style-type: none"> • Bucket and brush hand cleaning • High-pressure water • Sandblasting 	<ul style="list-style-type: none"> • <i>Do not use hydrochloric (muriatic) acid!!!</i> Clean with plain water, detergents, emulsifying agents, or suitable proprietary compounds. Manganese colored brick units tend to react to muriatic acid solutions and stain. Light-colored brick are more susceptible than darker units to "acid burn" and stains.
Same as light-colored units, etc., plus sand finish	<ul style="list-style-type: none"> • Bucket and brush hand cleaning • High-pressure water 	<ul style="list-style-type: none"> • Lightly apply either method. (See remarks for light-colored units, etc.) <i>Sandblasting is not recommended.</i>
Glazed brick	<ul style="list-style-type: none"> • Bucket and brush hand cleaning 	<ul style="list-style-type: none"> • Wipe glazed surface with soft cloth within a few minutes of laying units. Use soft sponge or brush plus ample water supply for final washing. Use detergents where necessary and acid solutions only for very difficult mortar stain. Do not use acid on salt glazed or metallic glazed brick. Do not use abrasive powders.
Colored mortars	<ul style="list-style-type: none"> • Method is usually controlled by the brick 	<ul style="list-style-type: none"> • Many manufacturers of colored mortars do not recommend chemical cleaning solutions. Most acids tend to bleach colored mortars. Mild detergent solutions are generally recommended.

Figure 16-1 Cleaning guide for new brick masonry. (From BIA Technical Note 20 Rev.)

16.1.3 Cleaning Fresh Mortar Smears

Although hydrochloric acid solutions are highly effective in removing mortar stains, they are not recommended for concrete masonry. Acid solutions remove the stain by dissolving the cement, but they also dissolve the cement matrix in the unit and etch the surface, leaving it porous and highly absorptive. As the cement is dissolved, more aggregate is exposed, changing both the color and the texture of the block.

Dry rubbing is usually sufficient for removing mortar stains from concrete masonry. To prevent smearing, mortar droppings and splatters should be almost dry before being removed. Large droppings can be pried off with a trowel point, putty knife, or chisel. The block surface can then be rubbed with another small piece of block, and finally with a stiff fiber-bristle or stainless steel brush.

On brick and other clay masonry units, the mortar must be thoroughly set before it can be properly removed. Trying to clean uncured mortar from the surface presses the cement paste into the unit pores, making it harder to

clean. Wooden paddles or nonmetallic scrapers should be used to remove large mortar droppings. For small splatters, stains, or the residue from larger pieces, a medium-soft fiber-bristle brush is usually sufficient.

Mortar that cures too long is harder and more expensive to remove than fresh splatters, and may require acid cleaning. Mild acid solutions easily dissolve thin layers of mortar. Large splatters should be scraped off first and, if necessary, the residue removed with acid. Hydrochloric acid (commonly known as muriatic acid) is suitable for cleaning clay masonry if it is diluted to a 5 or 10% solution (1 part acid to 20 parts water or 1 part acid to 9 parts water).

Mud, dirt, and soil can usually be washed away with a mild detergent solution consisting of $\frac{1}{2}$ cup dry measure of trisodium phosphate (TSP) and $\frac{1}{2}$ cup dry measure of laundry detergent to 1 gal of clean water. Dried mud may require the use of pressurized water or a proprietary "restoration" type cleaner containing hydrofluoric acid and phosphoric acid. Hydrofluoric acid, however, etches polished surfaces such as glass, marble, and granite, so adjacent materials must be protected from accidental contact. Hydrofluoric acid is not suitable for cleaning mortar stains and splatters because it cannot dissolve portland cement products.

All cleaning solutions, even detergent, should be tested for adverse effects on a small, inconspicuous area of the wall. Some detergents contain soluble salts that can contribute to efflorescence. Muriatic acid can leave a white scum on the wall if the residue of dissolved cement is not thoroughly rinsed after a brief dwell time and light scrubbing. White scum can be removed only with special proprietary compounds, or it may have to simply wear off. Detergent and acid solutions usually are applied by bucket and brush, but large jobs may require low-pressure spray application. The masonry should be thoroughly saturated from the top down before cleaning to prevent absorption of the acid or the dissolved mortar particles. Failure to adequately prewet a wall, or using an acid solution that is too strong will cause acid burn—a chemical reaction that changes the color of the masonry. Nonmetallic buckets, brushes, and tools must always be used with acid cleaners because the metals react with acid, leaving marks on the wall that can oxidize and leave stains. Muriatic acid can also "bleach" colored mortars.

16.2 EFFLORESCENCE AND STAINS ON UNIT MASONRY

White, brown, and green stains can appear on unit masonry surfaces because of excessive moisture in the wall, or improper cleaning methods. Stains can also be caused by other materials such as paint or welding splatter. Each type of stain has an appropriate cleaning method.

16.2.1 Efflorescence and Calcium Carbonate Stains

Efflorescence and calcium carbonate stains are the two most common forms of surface stains on masonry. Both are white and both are activated by excessive moisture in the wall, but beyond that, there are no similarities. Efflorescence is a powdery salt residue, while calcium carbonate stains are hard, sometimes shiny, and much more difficult to remove.

Efflorescence occurs when soluble salts in the units or mortar are taken into solution by water entering through joint separation cracks, faulty copings, leaky window flashing, or other construction defects. As the wall begins to dry, the salt solution migrates toward the surface through capillary pores. When the water evaporates, the salts are deposited on the face of the wall (see Fig. 16-2).



Figure 16-2 Efflorescence.

Hot summer months are not as conducive to efflorescence because the wetting and drying of the wall is generally quite rapid. In late fall, winter, and early spring, particularly after rainy periods, when evaporation is slower and temperatures cooler, efflorescence is more likely to appear.

Three simultaneous conditions must exist in order for efflorescence to occur: (1) soluble salts must be present within the masonry assembly; (2) there must be a source of water sufficiently in contact with the salts to form a solution; and (3) the wall construction must be such that paths exist for the migration of the salt solution to a surface where evaporation can take place (see Fig. 16-3). In conventional masonry construction exposed to weather, it is virtually impossible to ensure that no salts are present, no water penetrates the masonry, and no paths exist for migration. The most practical approach to the prevention and control of efflorescence is to reduce all of the contributing factors to a minimum.

Soluble salts may be present in either the masonry or the mortar, or may be absorbed into the wall through rain or groundwater. Since efflorescence usually appears on the face of the units, they are generally assumed to be at fault. This, however, is not usually the case. Virtually all clay brick contains at least some salts, but their efflorescing potential is small. The degree of probability may be easily determined by the wick test included in ASTM C67, *Standard Methods for Sampling and Testing Brick and Structural Clay Tile*. Brick units relatively free from impurities are readily available throughout the United States. Dense to moderately absorptive units are least troublesome. Researchers differ in their opinions on concrete masonry, some saying that it has even less efflorescing potential than clay products, and others recording 2 to 7 times as much soluble material.

Mortars also vary in the amounts of soluble salts they contain, depending on the type of cement used. Cements are generally the greatest source of soluble materials that contribute to efflorescence. Those with a high alkali content and limestone impurities are most likely to cause problems. Some companies have developed special “low alkali” and “non-staining” cements for use in masonry mortars. Hydrated limes are relatively pure and generally have 4 to 10 times less efflorescing potential than cements. Therefore, lime is one of the lesser sources, along with well-washed sand and clean, potable water. Soluble salts from the soil may be absorbed into masonry in contact with the ground through the capillary action of groundwater migrating

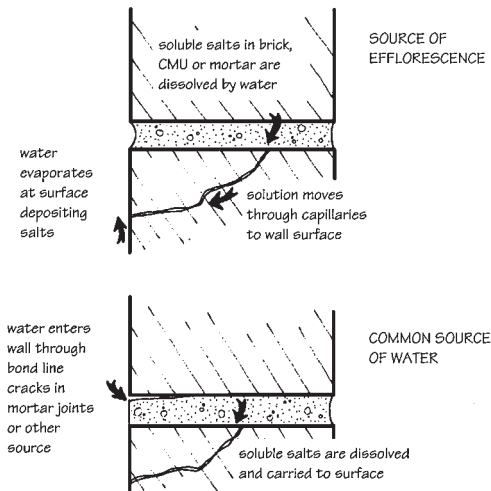


Figure 16-3 Efflorescence in masonry. (Courtesy Acme Brick Company, Fort Worth, Texas.)

upward into the units. Sulfurous gases in the atmosphere in highly industrialized areas may also contaminate the masonry with soluble salts through soaking with “acid rain.”

The source of moisture necessary to produce efflorescence may be either rainwater or the condensation of water vapor within the assembly. Water may also be present because unfinished walls were not properly protected from rain and snow during construction. “New building bloom” (efflorescence that occurs within the first year of the building’s completion) is often traced to slow evaporation of such moisture.

The most common cause of efflorescence is faulty design and construction practices. Regardless of impurities in the materials, it is unlikely that efflorescence will occur if proper precautions and high-quality workmanship are employed. Some of the more common malpractices are:

1. Failure to store masonry units off the ground and protect with waterproof covers
2. Failure to cover and protect unfinished walls
3. Inadequately flashed copings and parapet walls
4. Absence of drips on cornices or projecting members
5. Poorly filled mortar joints
6. Absence of dampproof courses at ground level
7. Failure to repair or patch cracked or broken mortar joints

8. Use of dense units and mortar, which absorb moisture through unrepaired cracks and are then slow to dry out

To minimize the possibility of efflorescence, the following measures are of greatest importance:

1. Use only units of low to moderate absorption or specify that the brick be tested for efflorescing potential in accordance with ASTM C67 and rated as “not effloresced.”
2. Use only low-alkali, non-staining cements in the mortar.
3. Properly protect materials before and during construction.
4. Install flashing and weep holes, caulking, and sealants at strategic locations to expedite the removal of moisture that has entered the wall.
5. Achieve good bond with compatible units and mortar.
6. Most important of all, construct full mortar joints.

These precautions are particularly important in regions with high annual rainfall. ASTM C1400, *Guide for the Reduction of Efflorescence Potential in New Masonry Walls*, addresses issues of moisture penetration, moisture drainage, design, and construction practices which will minimize the risk of this type of staining.

Efflorescence will often disappear with normal weathering if the source of moisture is located and stopped. Efflorescence can also be dry brushed, washed away by a thorough flushing with clean water, or scrubbed away with a brush.

Clear water repellents are often recommended as a solution to efflorescing problems. However, if the water repellent is applied to a wall that still contains both moisture and salts, the resulting problems may be even more damaging than the stain. The water in the wall will still take the salts into solution, and as it migrates toward the outer face, most of it will stop at the inner depth of the water repellent. The water will then evaporate through the surface as a vapor and deposit the salts inside the masonry unit. This interior crystalline buildup (sometimes called *subflorescence*) can exert tremendous pressure capable of spalling the unit face (see Fig. 16-4). Clear water repellent applications are generally not recommended as a treatment for efflorescence unless the chain of contributory conditions (moisture, salts, and migration paths) is also broken.

Calcium carbonate stains occur when calcium hydroxide from the mortar is leached to the surface, where it reacts with atmospheric carbon dioxide to form calcium carbonate. The calcium hydroxide (lime) is present not only in portland cement-lime mortars, but in masonry cement mortars as well, because it is a natural by-product of the cement hydration process itself. As the cement cures, it produces 12 to 20% of its weight in calcium hydroxide. Extended saturation of a wall through construction defects prolongs the hydration process and maximizes the amount of lime produced. The excess moisture also carries the calcium hydroxide to the wall surface where it reacts with carbon dioxide in the air to form calcium carbonate (limestone). The stains usually occur as hard, encrusted streaks coming from the mortar joints, and are sometimes referred to as “lime deposits” or “lime run” (see Fig. 16-5).

Before calcium carbonate stains can be removed, the source of moisture must be located and stopped. Once that is done, the stain and surrounding area should be saturated with water, and a dilute solution of 1 part hydrochloric (muriatic) acid to 9 parts water applied. With a stiff fiber-bristle

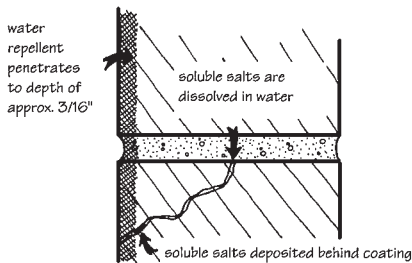


Figure 16-4 Water-repellent coatings can trap salts inside masonry. (Courtesy Acme Brick Company, Fort Worth, Texas.)



Figure 16-5 Calcium carbonate stain.

brush, the stain can be scrubbed away and the wall thoroughly rinsed with water to remove the acid and residue.

16.2.2 Vanadium and Manganese Stains

Two stains that are peculiar to clay products are green or yellow vanadium stains and brown manganese stains. *Vanadium* salts originate in the raw materials used to manufacture brick, and the stains occur on white or light-colored units. The chloride salts of vanadium require highly acidic leaching solutions, and the problem of green stain often does not occur unless the walls are washed down with a muriatic acid solution. To minimize the occurrence of green stain, do not use acid solutions to clean light-colored brick, and follow the recommendations of the brick manufacturer for the proper cleaning compounds and solutions. If green stains do appear as a result of acid washing, flush the wall with clean water and then wash or spray with a

solution of 2 lb of potassium or sodium hydroxide to 1 gal of water to neutralize the acid. After the solution has been on the wall for 2 or 3 days, the white residue may be hosed off with clean water.

Manganese stain may occur on the surface of mortar or bricks containing manganese coloring agents. The stain may be tan, brown, or gray, is oily in appearance, and may streak down over the face of the wall. The manufacturing process chemically changes the manganese into compounds that are soluble in weak acid solutions. The staining may occur because of acid cleaning procedures, or even because of acid rain in some industrial areas. Muriatic acid solutions should never be used to clean tan, brown, black, or gray brick or mortar unless the wall is thoroughly saturated with water before application and the acids are washed away with a rinsing operation.

Brown manganese stains can be removed with a 1:1:6 solution of acetic acid (80% or stronger), hydrogen peroxide (30 to 35%), and water. Wet the wall thoroughly, and brush or spray on the solution, but do not scrub. The reaction is generally very quick and the stain rapidly disappears. After the reaction is complete, rinse the wall thoroughly with water. Although this solution is very effective, it is dangerous to mix and use, and proper precaution should be taken to protect workers and adjacent surfaces. Manganese stains often recur after they are first removed, and the process must be repeated. To avoid manganese stains, always request and follow the recommendations of the manufacturer in cleaning brick that contains manganese coloring agents.

16.2.3 Stains from External Sources

The method of removing externally caused stains will depend on the type of material that has been splattered on, or absorbed by, the masonry. Many stains can be removed by scrubbing with ordinary kitchen cleansers. Others require the use of a *poultice* or paste made with a solvent or reagent and an inert material. The stain is dissolved, and the solution leached into the poultice. After drying, the powdery substance remaining is simply brushed off. Although repeated applications may be required, the poultice will prevent the stain from spreading during treatment, by actually pulling it from the pores of the masonry. Some of the more common stains and cleaning methods are listed below.

Paint stains on both brick and concrete masonry may be removed with a commercial paint remover, or a solution of 2 lb of trisodium phosphate in 1 gal of water. Apply the liquid with a brush, allow it to remain and soften the paint, and then remove with a scraper and wire brush. Rinse the surface afterward with clear water.

Iron stains or welding splatter are removed from clay and from concrete masonry in different ways. On clay brick, spray or brush the area with a solution of 1 lb of oxalic acid crystals, 1 gal of water, and $\frac{1}{2}$ lb of ammonium bifluoride to speed the reaction. This solution should be used with caution because it generates hydrofluoric acid, which will etch the brick surface. The etching will be more noticeable on smooth masonry. An alternative method, which may also be used on concrete masonry, uses 7 parts lime-free glycerine with a solution of 1 part sodium citrate in 6 parts lukewarm water mixed with whiting to form a poultice. Apply a thick paste and scrape off when dry. Repeat the process until the stain has disappeared, then rinse the area thoroughly with clear water.

Copper or bronze stains are removed from both clay and concrete masonry by a mixture in dry form of 1 part ammonium chloride and 4 parts

powdered talc, with ammonia water added to make a thick paste. Apply the paste over the stain and remove when it is dry using a scraper or, if working on glazed masonry, a wooden paddle.

Smoke stains are difficult to remove. Scrubbing with a scouring powder that contains bleach using a stiff-bristle brush will generally work well. Small, stubborn stains are better dealt with using a poultice of trichloroethylene and talc, but the area should be well ventilated to avoid a buildup of harmful fumes. In some instances where large areas have been stained, alkali detergents and commercial emulsifying agents may be brush or spray applied or used in steam cleaners. If given sufficient time to work, this method will work well.

For information on identifying unknown stains and determining appropriate cleaning methods, consult Grimm's handbook, *Cleaning Masonry—A Review of the Literature*. All proposed cleaning methods should be tested on a small area before general application is made to a wall or surface.

16.3 CLEANING STONE MASONRY

Mortar is sometimes smeared on stone surfaces during construction. Mortar smears can usually be removed by scrubbing with stone dust and fiber brushes wetted with white vinegar. To avoid smearing mortar across the stone surface, allow the mortar to take its initial set, and then remove it with a trowel rather than wiping with a cloth. Mortar can also be placed into head joints with a grout bag to minimize the amount of wet mix coming in contact with the stone surface. Acids or chemical cleaners are not usually required to clean new stone. If stubborn dirt or other foreign substances have become embedded in the surface, mild abrasive cleaners will usually remove them. If more aggressive methods are required, consult the stone fabricator about the most appropriate cleaning chemicals and procedures. Cleaning methods for existing stone surfaces should achieve a balance between removal of dirt and stains and protection of the stone. Processes that are too abrasive can destroy the stone's natural protection and expose more surface area to the environment. Existing stone should be cleaned in accordance with the methods recommended under historic masonry below.

16.4 CLEANING HISTORIC MASONRY

There are more than just cosmetic reasons to clean and maintain historic masonry buildings. In fact, cosmetic reasons alone may not always be sufficient justification for a full-scale cleaning program. The weathered patina of masonry often becomes as much a part of a building's character as the materials themselves. The unnecessary cleaning of otherwise undamaged or lightly soiled walls may do more harm if harsh chemicals or abrasive action remove too much of the "protective crust" that has formed on the surface. As long as it does not contribute to or conceal deterioration, it should be preserved. The body of the brick or stone underneath may be too soft to withstand the attack of urban pollutants.

On the other hand, excessive soiling can disguise or even contribute to physical damage of the masonry. A heavy dirt buildup may easily conceal cracks and other signs of deterioration that warrant investigation and repair, and a thorough investigation may not be effectively accomplished without first cleaning the surface.

Dirt may also cause or aggravate deterioration of the masonry. Its presence significantly increases the amount of moisture that is attracted to and held on a wall surface, and impedes natural drying after a rain. Prolonged dampness tends to enhance the chemical reactivity of the masonry with com-

mon atmospheric pollutants. It also increases the risk of freeze-thaw damage in the winter and the growth of “micro-vegetation” in warmer conditions. Water that gets into the wall from other sources is also trapped because it cannot evaporate at the surface, so concealed metal components and structural supports are subject to accelerated corrosion and failure. And moisture damage, of course, can go beyond the masonry wall itself to interior finishes and other adjacent elements.

If cleaning has been determined as a necessary and desirable part of the restoration or preservation process, the first step in developing a cleaning program and specification must be one of testing and evaluation. Rudimentary field examinations and laboratory chemical analysis can determine the relative inertness or reactivity of the masonry and the nature and composition of the dirt or stains.

Dirt (or soiling) generally refers to particulate surface deposits, while *stains* are produced by foreign matter that has penetrated into or permeated the masonry. Dirt may include such solids as dust, sand, grit, carbon soot, and inorganic sulfates. Stains include those of metallic origin such as iron or copper; industrial stains of grease, oil, and tar; biological and plant stains caused by lichens, moss, algae, and fungal growth such as mildew; and internally activated stains such as efflorescence, calcium carbonate, vanadium, and manganese. Surface coatings such as paint, wax, or water repellents may also be present.

There is no such thing as typical urban dirt, nor is there typical masonry when dealing with historic buildings. An extraordinary variety of geological and man-made materials have been used in masonry construction, and often in combination with one another. A single facade may incorporate several textures and colors of brick, terra cotta copings, or decorative elements, and two or more types of stone used as lintels, sills, cornices, or belt courses. Side and rear elevations that are less exposed to public view may also be of less expensive, softer materials. The degree of soiling also varies with geographic orientation, location relative to street and pedestrian traffic, height above ground level, and configuration of projecting elements. The cleaning program must be designed to preserve the integrity of the entire building fabric (including non-masonry materials such as wood, glass, and metal), as well as to protect adjacent buildings, the surrounding landscape, occupants, workers, and passersby. Each building presents a unique set of problems—some known and some unexpected—and each requires a unique solution. There are no standard specifications. The Construction Specifications Institute (CSI) and the Association for Preservation Technology International (APT) have jointly published a technical document entitled *Guide to Preparing Design and Construction Documents for Historic Projects* (CSI Document TD-2-8), which provides in-depth information on documenting existing conditions and preparing drawings and specifications for the restoration or rehabilitation of historic structures.

16.4.1 Testing

A cleaning program should be initiated with carefully planned, on-site testing of specific materials and cleaning methods, begun well in advance of necessary completion dates. An experienced preservation consultant or cleaning contractor should be hired to perform the testing separate and apart from the cleaning contract itself, even if the same contractor will be used for the actual cleaning.

Because of the number of unforeseeable factors and the uncertainty of the results, most test patches should be located in an inconspicuous area of the building. Paint removal testing, however, should be done near the front entrance to the building where the most layers of paint are likely to be. Test patches should also be representative of the different types of substrates involved, and the (often dissimilar) substances to be removed. To ensure the most accurate test results, remove as much of the dirt or stain as possible by hand scraping with wooden paddles or brushing with non-metallic bristle brushes before test cleaning—and follow the same procedure when full-scale cleaning begins.

Start with what the Secretary of the Interior's standards for historic rehabilitation call "the gentlest means possible." Carefully document each tested procedure as to number of applications, cleaning material and equipment, dwell time, and wash/rinse pressures. Even small buildings may require a variety or a combination of cleaning methods. The best approach is to find the gentlest technique that will remove the prevailing substance, and augment it with more aggressive localized cleaning in difficult areas. It is always better to under-clean rather than over-clean. If you are testing chemical cleaners, non-staining pH papers should be held on the surface of the masonry before and after to determine if any acidic or alkaline residue remains.

Test patches serve as the standard by which full-scale cleaning is judged. But do not evaluate the test areas until they are dry and have weathered as long as possible. Ideally, exposure to a complete 1 year weathering cycle will give the most accurate and reliable information. When this is not feasible, a minimum of 1 month should be allowed, during which there are several wetting cycles and a number of temperature variations. Tests should also be conducted under weather conditions similar to those anticipated during actual cleaning, particularly when using chemical compounds that are affected by weather. The dilution ratios and dwell times used successfully in one season may not be as effective in another. Remember, too, that tests are usually performed under optimum conditions. It is always easier to effectively clean small areas at ground level than to achieve the same results from a scaffolding or swing stage at higher wind elevations on a Friday afternoon when everyone is tired. Expectations should be realistically based on actual field conditions.

16.4.2 Cleaning Methods

There are several different levels of intervention that can be implemented, using prudent combinations of water, hand scrubbing, detergents, and chemicals. *Do not use abrasives.* Grit blasting, wet or dry, whether it uses sand, crushed nut shells, rice hulls, egg shells, silica flour, ground corncobs, or any other medium, removes dirt and stains by tearing away the surface of the substrate itself. It accelerates deterioration of the brick or stone, disintegrates mortar joints, and irreversibly damages the masonry, shortening the remaining life of the building.

Grinding and power sanding can be equally destructive. Most historic brick is soft by today's standards. Any cleaning method that removes or abrades the durable outer layers formed in the firing kiln or the protective crust formed by weathering exposes the soft inner body to harsh environmental deterioration. The cost is prohibitive in terms of damage to historic building materials that are neither indestructible nor renewable.

Water washing methods include soaking, pressure washing, pressure washing supplemented with detergents or surfactants, and steam cleaning. Most masonry can be cleaned with simple water washing without the need for more aggressive measures. The amount of soiling will determine the level at which testing should begin.

For light to moderate soiling, particularly on rough textured brick or stone, *water spray* at moderate pressure (200 to 600 psi) may be needed. Non-ionic detergents applied by bucket and brush, or added to the power spray, can hasten the cleaning process and reduce the amount of water that must be applied to the wall, but they must be thoroughly rinsed to remove any film or residue left on the surface.

Water soaking is effective for carbon or sulfate encrustations, which often build up in protected areas under cornices, eaves, and overhangs where rain cannot keep the wall clean. A fine mist sprayed on the wall for a prolonged period softens the crust by causing the dirt deposits to swell and loosen their grip on the masonry. The continuous application of water then rinses the deposits away, simulating the natural washing action of rain. A low to moderate pressure rinse may be needed as a final step. The volume of water required for cleaning can be enormous (9.8 million gal on Chicago's Field Museum). Precautions must be taken to prevent moisture damage to other parts of the building. Repair open mortar joints, replace deteriorated sealant joints, and check windows for glass that is loose before beginning work. In water soak applications, it is best to cover windows, doors, and lower courses of masonry to keep most of the water out.

Steam cleaning requires much less water, and is used almost exclusively for interior work. Steam is dangerous because it burns and because it obscures the visibility of the equipment operator. It can be very effective, though, on delicate, ornately carved stonework.

Chemical compounds are usually needed to remove heavy dirt buildup, wax coatings, water repellents, and paint. Acid-based cleaners are most effective for removing dirt, and alkaline cleaners for paint removal. The lime mortars used in historic masonry construction, however, are acid sensitive, and acid can also damage brick. To prevent the chemicals from penetrating beyond the layers of surface dirt, the walls must be thoroughly presoaked with water before application, and thoroughly rinsed with clean water afterward. Test patches must be used to determine the exact chemical concentrations and dwell times required for specific surfaces and specific soiling conditions.

Alkaline paint strippers are very effective in removing layers of paint from masonry buildings. It is important, however, to first determine whether the paint should be removed at all. Painted brick buildings were popular during several historic periods. Many were painted immediately after construction, sometimes to protect soft, inexpensive brick. If the underlying substrate is soft, low-fired brick, paint removal may be more damaging than beautifying in the long run.

16.4.3 Precautions

Because water is used in all masonry cleaning procedures, provisions must be made for adequate site drainage. The high volume of water also precludes cleaning during cold weather when there is any danger of the masonry freezing before it dries out. Effluent control and handling must also be provided when contaminants such as lead-based paints are involved, and chemical cleaning should not be performed under windy conditions when overspray or

drift could be a problem. Caution is essential to all phases of historic masonry cleaning, not only in the handling and treatment of the sometimes delicate building fabric itself.

16.5 REPAIR AND REPOINTING

The first priority in repairs to historic buildings should be identifying and treating the cause, rather than the effects, of deterioration and damage. Before stones cracked by settlement are repaired or replaced, the foundation itself must be stabilized, and roof leaks must be stopped before repairing moisture-damaged walls. If the symptoms rather than the disease are treated, the problems will recur.

16.5.1 Repairs

Begin with major structural work before undertaking minor repairs, and provide permanent weather protection as soon as possible. Be wary of methods that have not been extensively tested. Historic buildings should not be the testing grounds for new materials and procedures. Avoid the tendency to rush work, because shortcuts and poor craftsmanship compare poorly with the original work and result in jobs requiring additional repair. The most cost-effective approach is not necessarily the least expensive, but the one that will last longest, is technically best, and requires the least change to the historic property.

No matter how soiled the masonry itself is, or how much moisture it retains on the surface, much larger quantities of water will enter the wall through cracked or broken mortar joints, defective copings, and leaky roofs and gutters. Joint integrity must be maintained, not only for aesthetic reasons, but for structural soundness and weather protection as well. But repointing will not be effective if there are other sources of moisture that have not been identified and repaired. If the roof leaks, fix it. If the coping is ineffective in stopping water infiltration, repair it. Then repoint the mortar as needed. To finish the job, look carefully at caulking and sealant joints. There is a limit to the effective service life of these materials, even under optimum conditions. Periodic maintenance and repair are always necessary and should be scheduled regularly to avoid more costly long-term damage from water.

16.5.2 Joint Preparation

Deteriorated mortar joints in existing masonry can be cleaned out and repointed with fresh mortar. Mortar joints deteriorate for many reasons:

- Water, wind, and pollution erode the mortar.
- Historic mortars made with little or no portland cement are soft, and often more susceptible to weathering.
- Uneven settlement can cause cracks to form in the mortar joints.
- Mortar joints are only partially filled during construction, or mortar inadequately bonds to the units, allowing excessive moisture to penetrate the wall.
- Walls saturated by moisture can freeze and thaw again, eventually spalling both the mortar and the masonry.

Raking refers to the process of removing or cutting out the old mortar. Mortar joints should be raked out to a depth of $\frac{1}{2}$ to $\frac{3}{4}$ in. (see Fig. 16-6). If

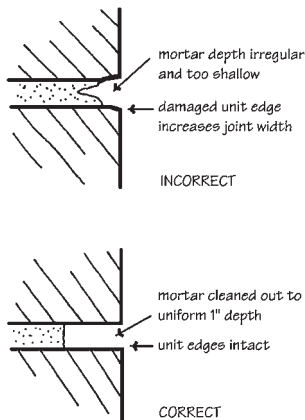


Figure 16-6 Raking out defective mortar joints. (From *U.S. National Park Service, Preservation Brief No. 2.*)

the mortar is still unsound, cut the joint deeper. Mortar can be removed with a hand-held grinder, a small mason's chisel, or with a special raking tool. If a grinder is used to rake vertical head joints, be careful not to cut into the brick courses above or below. Before repointing, brush all loose fragments and dust from the joint or flush them out with a stream of water or pressurized air. ASTM E2260, *Guide for Repointing (Tuckpointing) Historic Masonry* addresses mortar evaluation, mortar removal techniques, mortar selection, and procedures for joint preparation, mortar placement, and curing.

16.5.3 Mortar

Repointing mortar should match the existing material as closely as possible in strength, hardness, color, and texture. Historic mortars were generally soft and may have been mixed from clay, gypsum, lime, natural cement, and some later ones with portland cement. ASTM C1324, *Method for Examination and Analysis of Hardened Masonry Mortar* can be used to determine the ingredients and proportions by petrographic and chemical analysis. Mortars containing portland cement are much harder than these older mixes, and in some cases, harder than the brick or stone itself. The new mortar should have a similar or lower compressive strength and higher vapor permeability than the stones or bricks in the wall. A hard mortar used with soft brick or stone can cause deterioration of the masonry because the two components do not respond to temperature and moisture changes at the same rate, or to the same degree. The softer material will absorb more movement stress and more moisture, and hard mortar can act as a wedge, breaking the edges off the units (see *Fig. 16-7*). Many buildings have been irrepara-

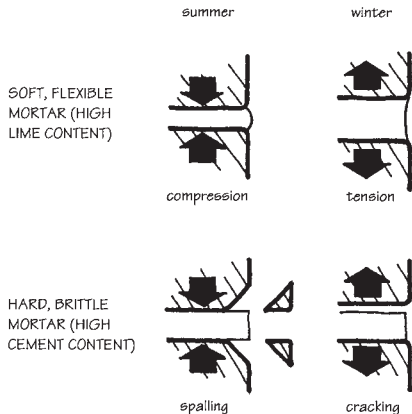


Figure 16-7 Hard mortar can damage soft historic brick or stone. (From *U.S. National Park Service, Preservation Brief No. 2.*)

bly damaged in this manner. Strong portland cement mortars may also shrink, leaving minute cracks at the mortar-to-unit interface.

Recommendations for repointing mortar vary with almost every source consulted. The Preservation Assistance Division of the U.S. National Park Service recommends lime-sand mortars with the optional addition of portland cement not to exceed 20% of the total volume of cement and lime. For brick masonry restoration in which the ingredients of the original mortar are unknown, BIA recommends an ASTM C270 Type N or Type O mortar mixed proportionally with portland cement, lime, and sand. The appendix to ASTM C270 recommends Type N, O, or K, depending on conditions of exposure. The recommendations in *Fig. 16-8* from the Ontario Ministry of Citizenship and Culture are based both on expected weather exposure and the type of masonry involved.

To compensate for shrinkage in mortars containing portland cement, prehydrate the mortar by first mixing the dry ingredients with only enough water to produce a damp, unworkable mix (one that will retain its form when pressed into a ball). Keep the mortar in this damp condition for 1 to 2 hours and then add enough water to bring it to a working consistency somewhat drier than conventional mortar. The drier mix is easier to place, and doesn't flow to the bottom of the joints as easily. To see if the color of the new mortar matches the color of the old, test a sample area in an inconspicuous location, using a garden hose to soak a portion of the wall. The color of the new mix should match the darker, wet color of the existing. Minor adjustments can be made by adding or subtracting sand or cement, but records should be kept of exact proportions so that the selected color can be reproduced consistently throughout the job.

Masonry Material	Recommended Mortar Mix Proportions for Various Weathering Exposures		
	Sheltered	Moderate	Severe
Highly durable granite or hard brick	1 part cement 2 parts lime 8 to 9 parts sand	1 part cement 1½ parts lime 5 to 6 parts sand	1 part cement ½ part lime 4 to 4½ parts sand
Moderately durable stone or brick	1 part cement 3 parts lime 10 to 12 parts sand	1 part cement 2 parts lime 8 to 9 parts sand	1 part cement 1½ parts lime 5 to 6 parts sand
Poorly durable soft brick or friable stone	0 parts cement 2 parts hydraulic lime 5 parts sand	1 part cement 3 parts lime 10 to 12 parts sand	1 part cement 2 parts lime 8 to 9 parts sand

Figure 16-8 Recommended repointing mortars. (Adapted from the Ontario Ministry of Citizenship and Culture, Annotated Master Specifications for the Cleaning and Repointing of Historic Masonry Structures, 1985.)

16.5.4 Pointing

To ensure good bond with brick and stone, dampen the cleaned joints with water just before beginning work. Mortar is placed using a small mortar board called a “hawk” and a tuckpointer’s trowel, which looks like a jointer, but has a flat blade. Vertical joints are filled first, then horizontal joints, with the mortar applied in thin ¼-in. layers that are allowed to become “thumbprint hard” before placing the next layer. Joints should not be overfilled to the point where mortar hides the edges of the units. This makes the joint appear too wide, and the edges break off too easily, leaving voids through which moisture can penetrate. For brick or stone that has weathered to a rounded profile, the new mortar joint should be slightly recessed from the unit surface and tooled concave to avoid “feathered” edges (see Fig. 16-9). Wide, feathered joints also change the appearance of the masonry (see Fig. 16-10). Stippling joints with the bristles of a stiff, nonmetallic brush while the mortar is still soft will give it a worn appearance. Moist curing may be necessary in hot, dry weather to assure hydration of the cement and good mortar bond to the units.

16.6 COLOR MATCHING BRICK

Once the brick or stone in a wall begins to crumble, the deterioration will continue, often at an accelerated rate. The condition can be remedied only by replacement of the affected unit. Where damage or deterioration is extensive, replacement of entire sections of masonry may be required. The brick, stone, terra cotta, or clay tile used for such repairs should match the original material characteristics as closely as possible. Where damage has been caused by excessive moisture penetration from groundwater migration, the installation of a waterproof membrane as a dampproof course may be possible as sections of the original masonry are removed.

Whenever replacement of brick masonry is required, or when additions to existing buildings are necessary, consideration must be given to color matching. Matching the brick on an existing building involves more than just picking a unit color. To achieve an acceptable result, the mortar mix, the joint tooling, and the moisture content of the brick must also be controlled.

The first consideration is whether to match the brick as is (dirt and all) or to clean the masonry and then match the original color. The question may

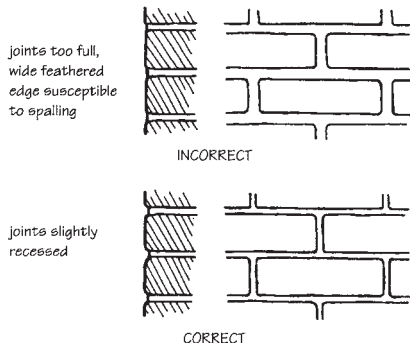


Figure 16-9 Correctly and incorrectly repointed mortar joints. (From U.S. National Park Service Preservation Brief No. 2.)



Figure 16-10 Original (left) and repointed (right) halves of building have very different appearance.

be at least partially answered by the age of the building itself. If constructed in the last 10 to 20 years, it is likely that the original brick is still available. Cleaning the existing walls may prove to be less expensive than a custom clay blend to match the soiled brick. Older brick may be unavailable, documentation may not exist to identify the original units, or cleaning may be unwarranted or undesirable from a historic perspective. In such cases, some

brick manufacturers will do custom color matching but the cost may be prohibitive.

Contact the brick manufacturer 6 to 10 months ahead of construction, to give them time for several test runs if necessary. Make two separate counts of the percentages of light and dark range units in a typical blend area close to the location of the repair or the planned addition. Request at least 48 loose sample bricks in the selected colors. These samples should be numbered on the back, and the manufacturer should retain duplicates at the plant. Compare the samples to the existing walls and view them at distances of 20 ft and 60 ft. Do not be influenced by slight size, finish, or texture variations that are noticeable only at close range—color is the most important factor. When comparing the units, be sure that both the samples and the existing walls are surface dry. If you are not satisfied with the samples, order more.

Deliberately choose a color range that has slightly *less* contrast than the existing wall. That is, make sure the darkest sample you choose is a little lighter than the darkest brick in the wall, and the lightest sample slightly darker than the lightest brick in the wall. When you are satisfied with the color range and blend of the units, return 10 approved samples to the plant, packaged so that they do not become separated in transit.

The mortar must also match the existing to achieve good results. If you can identify the original mortar, specify the same type, proportion, and materials (i.e., masonry cement or portland and lime mix). If a colored mortar is needed, the manufacturer can help in selecting or custom blending the pigments. Specify controls on job-site mortar mixing to ensure consistent color. Each batch of mortar must be mixed in exactly the same way, using exactly the same ingredients. The type and amount of each ingredient affect mortar color. Use only one brand of cement, one brand of lime, and one source and color of sand throughout the entire job. Mix only full batches of mortar, maintain a consistent water content, and mix each batch the same length of time. When you cannot exactly match the existing brick color, construct several sample panels with varying mortar colors to find the one that minimizes the difference.

To achieve consistency in color pattern on the wall, units with a pronounced range of colors, or mixes that contain more than one color, must be properly blended. Blending problems are rare in historic buildings because careful hand blending at the job site was necessary after the shipment was dumped from the back of a wagon or cart. Manufacturers today routinely perform hand blending operations at the plant and ship the brick on pallets that hold the equivalent of 500 standard modular units. Since the units typically go to the scaffold in batches of only about 100, however, the masonry contractor must unstack the bricks according to instructions on each pallet and distribute them to the bricklayers uniformly. Narrow color ranges present fewer potential problems than wider ranges or blends of more than one color (*refer to Fig. 15-6*). Always specify that units be laid in the wall in a blend that will result in even color without patchy areas.

Establish a standard of acceptable workmanship for color blending by specifying a sample panel for approval. This panel should be constructed in addition to any that were used in the selection process, because it must be built with brick from the actual production run used in the building. The sample panel can also be used to set standards for joint tooling. The joint size and shape, of course, must match the existing, but tooling should also be consistent to avoid the patchy effect of light and dark joints. Wetter mortar tools to a lighter color than drier mortar because more cement paste is drawn to the surface. Tooling therefore, must occur at the same moisture content

throughout the job rather than after a set number of courses or bricks, or elapsed time.

Brick moisture content at the time of laying affects mortar curing time. An *inconsistent* moisture content therefore affects the color of the finished joint. If an unprotected pallet of brick, for instance, becomes partially wet during an overnight rain, the wet units will cause patches of lighter-colored joints because their higher moisture content keeps the mortar moist for a longer period of time than adjacent areas (refer to Chapter 15). Always specify weather protection, not only for unfinished walls, but also for units and mortar ingredients.

Visual separation elements can also help minimize the effect of any contrast between new and existing walls. An entry, a decorative panel with a different joint type, or even a small projecting pilaster will help isolate the different sections instead of abutting them for critical comparison.

17

QUALITY ASSURANCE AND QUALITY CONTROL

Building owners want to be sure that they are getting what they pay for in terms of the quality of the building's construction. Quality assurance programs and quality control procedures are used toward that end.

Quality is defined by the International Organization for Standardization (ISO) as the "totality of features and characteristics of a product or service that bear on its ability to satisfy stated or implied needs." In most construction projects, the particular standard of quality that will apply in a given case is established by and measured in terms of the contract document requirements. The owner initially establishes a general standard of quality, which is then developed by the architect/engineer into specific terms and incorporated into the contract documents. The standard of quality required on a given project will vary depending on the needs of the owner, the project type, and the established schedule and budget.

What is the difference between the terms *quality assurance* and *quality control*? ASTM defines quality assurance as "all planned and systematic actions necessary to provide adequate confidence that an item or a facility will perform satisfactorily in service" and quality control as "those quality assurance actions which provide a means to control and measure the characteristics of an item, process, or facility to established requirements." In specification language, to assure means "to give confidence to," and to ensure means "to make certain in a way that eliminates the possibility of error." Quality assurance in construction could therefore be considered as the A/E's administrative process for *assuring* that the work will conform to the standard of quality established by the contract documents, and quality control as the procedures for testing, inspecting, checking, and verifying to *ensure* that the work meets the required standard of quality established by the contract documents. The A/E can endeavor to "assure" quality, but the contractor alone has control over construction means, methods, techniques, sequences, and procedures, and therefore only the contractor can "control" quality.

17.1 STANDARD OF QUALITY

The American Institute of Architects (AIA) Document A201, *General Conditions of the Contract for Construction*, contains very broad quality assurance and quality control provisions. The general requirements in Division 1 of a project specification expand on these provisions, but are still written broadly enough to apply to the work of all the specification sections. Each technical section of Divisions 2 through 16 of the specifications includes the specific quality assurance and quality control measures that may be required for that particular section.

The AIA General Conditions establish very broadly that materials and equipment must be of “good quality and new”; that work must be free of defects not inherent in the quality required or permitted by the contract documents; and that the work must conform to requirements of the contract documents. More detailed requirements may be elaborated in supplementary conditions, and in the project specifications. The general requirements contained in Division 1 of the project specifications may include several sections that help define project quality standards. The general requirements also establish administrative and procedural requirements that are just as important in achieving the required project quality as the technical standards in Divisions 2 through 16.

A standard of quality may be established in different ways, depending on the method of specifying. *Descriptive specifications* identify exact properties of materials and methods of installation without using proprietary names. *Proprietary specifications* list specific products, materials, or manufacturers by brand name, model number, and other proprietary information. *Reference standard specifications* stipulate minimum quality standards for products, materials, and processes based on established industry standards. *Performance specifications* establish a standard of quality by describing required results, the criteria by which performance will be judged, and the method(s) by which it can be verified.

17.2 QUALITY ASSURANCE PROGRAM

The MSJC Code and Specifications require that the specifier designate Level 1, Level 2, or Level 3 Quality Assurance as appropriate to the project type and function (see *Fig. 17-1*).

AIA Document A201 requires that the A/E “endeavor to guard the Owner against defects and deficiencies in the Work.” The A/E does not have “control” of the work, and therefore cannot “control” quality. But the A/E can attempt to “assure” that the specified standard of quality is attained by developing and implementing a quality assurance program. A quality assurance program includes establishing

- Administrative procedures, rights, and responsibilities
- Required submittals, inspections, and tests
- Methods for resolving non-conforming conditions
- Required records

17.2.1 Quality Assurance Requirements in Building Codes

The *International Building Code* and the *MSJC Building Code Requirements for Masonry Structures* both contain specific mandated requirements for quality assurance. Both are based on type of facility and defined risk categories. The IBC and MSJC requirements are similar, but use slightly different terminology. The MSJC requirements are tabulated in *Figs. 17-1* and *17-2*. Level 2

Minimum Required Quality Assurance Level			
Description	Level 1	Level 2	Level 3
Non-essential facilities [§] designed in accordance with empirical requirements, masonry veneers and glass unit masonry	X		
Essential facilities [§] designed in accordance with empirical requirements, masonry veneers and glass unit masonry		X	
Non-essential facilities [§] designed in accordance with allowable stress, strength design, or prestressed masonry requirements		X	
Essential facilities [§] designed in accordance with allowable stress, strength design, or prestressed masonry requirements			X

[§] Essential and non-essential facilities as defined by adopted building code or by ASCE 7-98.

Figure 17-1 Minimum level of quality assurance tests, submittals, and inspections required by MSJC Code and Specifications. (*From MSJC Building Code Requirements for Masonry Structures, ACI 530/ASCE 5/TMS 402, and Specifications for Masonry Structures, ACI 530.1/ASCE 6/TMS 602, 2002 edition.*)

Quality Assurance under the MSJC Code is essentially the same as Level 1 Special Inspection under IBC requirements, and Level 3 Quality Assurance is the same as Level 2 Special Inspection.

17.2.2 Quality Assurance Requirements in the General Conditions

The foundation of the quality assurance program is laid in the AIA General Conditions, which stipulate that, when required by the A/E, the contractor must “furnish satisfactory evidence as to the kind and quality of materials and equipment” to be furnished under the contract. The A/E usually requires that such evidence be submitted in the form of shop drawings, product data, and samples. Through review of such submittals, the A/E has an opportunity before work begins to verify that the materials and equipment proposed are in conformance with the requirements of the contract documents. Division 1 sections establish procedural requirements for such submittals, but the informational content and the physical examples themselves help assure that the design intent and required standard of quality are understood and will be met.

17.2.3 Quality Assurance Requirements in the Specifications

Division 1 may include several project specification sections that establish quality assurance procedures, including project meetings, submittals, and product options and substitutions. Divisions 2 through 16 of the Specifications are composed of individual technical sections, each addressing a distinct subject area. With each subject come specific issues and requirements concerning quality assurance and quality control. Each part

Quality Assurance	Minimum Tests and Submittals	Minimum Inspection
Level 1 (not required by International Building Code)	Certificates for materials used in masonry construction indicating compliance with the contract documents	Verify compliance with the approved submittals
Level 2 (similar to International Building Code Level 1 Special Inspection)	Certificates for materials used in masonry construction indicating compliance with the contract documents Verification of f'_m prior to construction, except where specifically exempted by code	As masonry construction begins, verify the following are in compliance <ul style="list-style-type: none"> • proportions of site-prepared mortar • construction of mortar joints • location of reinforcement, connectors, and prestressing tendons and anchorages <p>Prior to grouting, verify the following are in compliance</p> <ul style="list-style-type: none"> • grout space • grade and size of reinforcement, prestressing tendons and anchorages • placement of reinforcement, connectors, and prestressing tendons and anchorages • proportions of site-prepared grout and prestressing grout for bonded tendons • construction of mortar joints <p>Verify that the placement of grout and prestressing grout for bonded tendons is in compliance.</p> <p>Observe preparation of grout specimens, mortar specimens, and/or prisms</p> <p>Verify compliance with the required inspection provisions of the contract documents and the approved submittals.</p>
Level 3 (similar to International Building Code Level 2 Special Inspection)	Certificates for materials used in masonry construction indicating compliance with the contract documents Verification of f'_m <ul style="list-style-type: none"> • prior to construction • every 5000 sq.ft. during construction <p>Verification of proportions of materials in mortar and grout as delivered to the site</p>	From the beginning of masonry construction and continuously during construction of masonry, verify the following are in compliance <ul style="list-style-type: none"> • proportions of site-mixed mortar, grout, and prestressing grout for bonded tendons • grade and size of reinforcement, prestressing tendons and anchorages • placement of masonry units and construction of mortar joints • placement of reinforcement, connectors, and prestressing tendons and anchorages • grout space prior to grouting • placement of grout and prestressing grout for bonded tendons <p>Observe preparation of grout specimens, mortar specimens, and/or prisms</p> <p>Verify compliance with the required inspection provisions of the contract documents and the approved submittals.</p>

Figure 17-2 Requirements for Quality Assurance Levels 1, 2, and 3. (From *MSJC Building Code Requirements for Masonry Structures, ACI 530/ASCE 5/TMS 402, and Specifications for Masonry Structures, ACI 530.1/ASCE 6/TMS 602, 2002 edition.*)

of the CSI Three-Part SectionFormat™ addresses different types of requirements. Since quality assurance is an administrative process, quality assurance provisions are addressed in Part 1, General, including articles entitled “Submittals” and “Quality Assurance.”

The submittals article may include paragraphs on

- Shop drawings, product data, and samples
- Quality assurance and quality control submittals (which may include design data, test reports, certificates, manufacturer's instructions, and manufacturer's field reports deemed necessary to assure that the quality of the work meets the requirements of the contract documents)
- Closeout submittals (which may include project record documents, operation and maintenance data, and warranty information)

Quality control submittals are different from shop drawings, product data, and samples. They are generally required to document the results of source quality control and field quality control procedures specified in Part 2 and Part 3 of the specification section. Quality control submittals are required as part of a quality assurance program to verify and document that the required quality control procedures have been performed.

The quality assurance article requirements include prerequisites, standards, limitations, and criteria that establish an overall level of quality for products and workmanship under a particular specification section. On any given project, requirements might include

- Qualifications
- Regulatory requirements
- Certifications
- Field samples
- Mock-ups
- Preinstallation meetings

17.3 QUALITY CONTROL PROCEDURES

Quality control includes the systematic performance of inspection and testing to ensure conformance with the required standard of quality. Specific quality control procedures may be required by the contract documents, but other quality control measures are self-imposed by responsible contractors as a normal part of good business practice.

The contract documents establish a standard of quality for various materials, products, and procedures required for the work. To ensure that the specified standard of quality is achieved, the contractor, materials suppliers, manufacturers, fabricators, and installers execute required quality control procedures, and implement other quality control measures they may deem necessary. Quality control includes not only laboratory and field testing and third-party inspection, but simple checking and verifying to ensure that the materials, products, systems, and equipment supplied conform to the specified requirements.

The contractor's quality control begins with the General Conditions stipulation that field measurements and site conditions be correlated with the contract documents before beginning work. Errors, inconsistencies, or omissions discovered must be reported to the A/E for resolution. The General Conditions also establish the right of the owner to require independent testing and inspection, and the contractor's responsibility for securing jurisdictional testing, inspection, and approvals.

17.3.1 Quality Control Requirements in the General Conditions

The AIA General Conditions require the contractor to achieve the specified standard of quality and prevent defective work through control of construc-

tion means, methods, techniques, sequences, and procedures. The General Conditions also assign the contractor the responsibility for coordinating, supervising, and directing the work. The contractor is not relieved of these obligations by the activities or duties of the A/E during the contract administration process.

17.3.2 Quality Control Requirements in the Specifications

The Division 1 sections on quality control include testing laboratory services, inspection services, field samples, mock-ups, contractor's quality control, and manufacturer's field services. These general requirements should cover only the administrative and procedural aspects of quality control that are applicable to all sections of the specifications. Requirements for specific tests, services, or field samples should be covered in the technical sections to which they apply.

The technical sections in Divisions 2 through 16 of the Specifications will vary in the need for, requirements of, and applicability of specific quality control procedures. Part 1 should list specific administrative and procedural requirements that apply to a particular section. Part 2 should specify source quality control, and Part 3 should cover field quality control.

Part 1 General

- *Quality control submittals.* Should list the submittals required for this section of the work, including as appropriate design data, test reports, certificates, manufacturer's instructions, and manufacturer's field reports.

Part 2 Products

- *Source quality control.* Involves checking material or product quality prior to incorporation in the project. Material suppliers implement quality control procedures prior to shipping to manufacturers. Manufacturers incorporate quality control procedures in their manufacturing processes. Manufactured components may in turn be fabricated into larger units that may also be subject to quality control requirements. An example would be a system involving components from several specification sections, which together must meet specific test criteria related to fire resistance ratings.
- *Fabrication tolerances.* Establish a dimensional or statistical range of acceptability for products, which the manufacturer or fabricator must control to ensure proper fit and coordination.
- *Source testing.* May involve the manufacturer or fabricator periodically obtaining or performing tests for verification of conformance with quality standards, for example, sieve analysis of soil materials or aggregates, compressive strength tests for masonry units, acoustical rating analyses of doors, or thermal transmission characteristics of windows. May also include requirements for the owner's independent agent to perform tests of materials sampled at the plant, shop, mill, or factory.
- *Source inspection.* May require owner's independent agent (such as a testing agency or the A/E) to perform inspections at the plant, shop, mill, or factory.
- *Verification of performance.* May require compliance with specified performance criteria before items leave the shop or plant.

Part 3 Execution

- **Acceptable installers.** Quality can be enhanced by the contractor's use of subcontractors and craftsmen with qualifications and experience in a particular trade or with certain expertise for special products or systems types. This article is suggested for use in sections for historical projects, testing and balancing of mechanical systems, special finishes, and others that may require a high quality of workmanship.
- **Site tolerances.** Establish an acceptable range of deviation from specified dimensions. Contractor is required to control dimensional tolerances, and verification may be required if the deviation appears visually unacceptable or interferes with performance requirements. Dimensional tolerances may involve such issues as surface flatness, levelness, plumbness, or alignment. Frequency of the deviation from tolerances is sometimes controversial. A tolerance that indicates that deviation shall not exceed $\frac{1}{4}$ in. in 10 ft may be questioned as to direction and whether the deviation is cumulative (e.g., $\frac{3}{4}$ in. in 30 ft), fragmentary (e.g., $\frac{1}{4}$ in. in 1 ft), or multiple (e.g., $\frac{1}{4}$ in. every 6 in. or so).
- **Field quality control.** Represents the last form of verification and may form the basis for decisions about defective work during or after installation.
 - **Site tests.** Usually involve quality control of variable conditions. Test methods, frequency interval, and location of testing are important issues. Field testing may involve soil compaction, load tests, compression tests, and various forms of non-destructive testing. Field testing may not always be performed at the site but may be performed on samples taken from the site.
 - **Inspection.** May involve simple visual observation for conformance with certain specified criteria, or may require third-party inspection of construction to verify conformance with contract requirements.
 - **Manufacturers' field service.** May require an authorized manufacturer's representative to visit the site to instruct or supervise installer in the installation/application of a product or system, or for training on, start-up of, or demonstration of specialized equipment. The manufacturer's field service may be required to determine or verify compliance with manufacturer's instructions. A manufacturer's field report as a quality control submittal should be required for these services.

17.4 FIELD OBSERVATION AND INSPECTION

The term *field observation* is often used as an architectural term denoting the type of periodic site visits associated with the services of a standard design services contract with a building owner. The term *inspection* more often implies special services that are more time-intensive and typically associated with structural engineering services and construction quality control. The items and issues that should be covered under an architect's field observation services are outlined in Chapter 18. The following discussion covers engineering inspection of structural masonry. Refer also to Chapter 12 for more on structural masonry inspection.

The owner typically engages independent testing laboratories and special inspectors to test, inspect, and verify the quality of work. Additional testing and inspection beyond the minimum required by code may be specified for some projects. Testing laboratories and inspectors are normally selected for their qualifications in a particular area of expertise. Testing laboratories

for masonry construction should be accredited in accordance with ASTM C1093, *Standard Practice for Accreditation of Testing Agencies for Unit Masonry*. Quality control testing and inspection may also be required by governmental authorities having jurisdiction over the project. This may involve tests, inspections, and approvals of portions of the work as required by building codes, laws, ordinances, rules, regulations, or orders of public authorities. Any required certificates of testing, inspection, or approvals by the building inspector are secured by the contractor and delivered to the A/E as quality control submittals. The contractor may also obtain independent testing and inspection services as a part of its own quality control program.

17.5 INDUSTRY STANDARDS FOR MASONRY

Industry standards such as those developed and published by the American Society for Testing and Materials (ASTM) are an important part of quality assurance and quality control in construction. Some standards establish minimum requirements for products or systems, and others outline standardized testing procedures for verifying compliance with the requirements stated in the contract documents.

At last count, there were more than 80 ASTM standards on masonry and masonry-related products, with more in development. Most project specifications, however, require reference only to a core group of standards that apply to the most frequently used products and systems. Because there are so many different products and materials that fall under the umbrella of the term *masonry*, there are perhaps more standards than for other construction systems. Some standards, however, are embedded references within other standards and ordinarily do not require specific citation in project specifications. Others apply to specialty products such as sewer brick, chemical-resistant units and mortar, high-temperature refractory brick, and clay flue liners that are outside the scope of the typical design project. Still other standards are used primarily for research and product development rather than building construction.

Many ASTM standards cover more than one grade, type, or class of material or product from which the specifier must choose. Some also contain language designating which requirements govern by default if the project specifications fail to stipulate a preference. The following summary of standards should serve as a checklist in preparing project specs and developing a quality assurance and quality control testing program.

17.5.1 Standards for Clay Masonry Units

ASTM C216, Standard Specification for Facing Brick (Solid Masonry Units Made of Clay or Shale). Face bricks are solid clay units for exposed applications where the appearance of the brick is an important consideration in the design. "Solid units" are defined as those with a maximum cored area of 25%. ASTM C216 covers two grades and three types of face brick. Brick *type* designates size tolerance and allowable chippage and distortion based on desired appearance. Type FBS (Standard) is the industry standard and the type of face brick used in most commercial construction. Type FBX (Select) has tighter size tolerances and less allowable chippage for use in applications where a crisp, linear appearance is desired such as stack bond masonry. Type FBA (Architectural) is non-uniform in size and texture, producing characteristic "architectural" effects such as those typical of, or required to simulate, hand-made brick. Type FBA is

popular for residential masonry styles because of its softer profile and less commercial look. All three brick types must meet the same strength and physical property criteria, but brick type is not related to color or color range. If the project specifications do not identify a specific proprietary product or designate brick type, ASTM C216 states that Type FBS standards shall govern.

Brick *grade* classifies units according to their resistance to damage from freezing when they are wet. The property requirements for Grades SW and MW are given in a table that covers minimum compressive strength, maximum water absorption, and minimum saturation coefficient (see Chapter 3). These properties are tested in accordance with ASTM C67, *Standard Test Methods of Sampling and Testing Brick and Structural Clay Tile*. Since ASTM C67 is referenced in ASTM C216, it is not necessary for the specifier to list ASTM C67 as a separate reference standard. If the brick is specified to meet the requirements of ASTM C216, that automatically requires that the units be tested for compliance in accordance with ASTM C67 methods and procedures.

In general, Grade SW (Severe Weathering) should be specified when a “high and uniform” resistance to damage from cyclic freezing is required and when the brick is likely to be frozen when it is saturated with water. Grade MW (Moderate Weathering) should be specified where only moderate resistance to damage from cyclic freezing is required and when the brick may be damp but not saturated when freezing occurs. ASTM C216 includes a table of grade recommendations for various types of exposure and a related map of geographic weathering regions (see Chapter 3). If the project specifications do not designate the required grade, Grade SW is the default standard, and Grade SW may be substituted by the supplier if Grade MW is specified.

Grade SW brick is required by ASTM C216 to have a minimum average *gross area* compressive strength of 3000 psi, and Grade MW brick, 2500 psi. These strengths are more than adequate for most non-loadbearing applications, and the majority of brick produced in the United States and Canada is much stronger. If a specific unit strength requirement greater than the standard minimum is required, that compressive strength should be required by the project specifications.

ASTM C216 also requires that brick be tested for efflorescence in accordance with ASTM C67 and be rated “not effloresced.” Color is not covered in this standard, so the specifier must designate the desired color, by specifying a proprietary product, with color and color range verified with a sample panel or mock-up panel.

ASTM C62, Standard Specification for Building Brick (Solid Masonry Units Made from Clay or Shale).

Building brick (sometimes called common brick) is used primarily for utilitarian applications or as a backing for other finishes, where strength and durability are more important than appearance. ASTM C62 covers Grades SW and MW on the basis of the same physical requirements for durability and resistance to freeze-thaw weathering as face brick. Building brick is also available in Grade NW (No Weathering), which is permitted only for interior work where there will be no weather exposure.

This standard lists permissible variations in size, but does not classify units by various types. The size tolerances listed apply to all ASTM C62 brick. Since these units are generally used in unexposed applications, there is no requirement for efflorescence testing. The discussion of compressive

strength requirements under ASTM C216 above also applies to building brick.

ASTM C652, Standard Specification for Hollow Brick (Hollow Masonry Units Made from Clay or Shale). ASTM C652 covers hollow brick with core areas between 25 and 40% (Class H40V) and between 40 and 60% (Class H60V). The two grades listed correspond to the same requirements for durability as for face brick—Grade SW (Severe Weathering) and Grade MW (Moderate Weathering). Types HBX (Select), HBS (Standard), and HBA (Architectural) are comparable to face brick types FBX, FBS, and FBA, respectively. Another type, HBB, is for general use where appearance is not a consideration and greater variation in size is permissible. Type HBB is the hollow brick equivalent of ASTM C62 building brick. When the project specification does not designate brick type, requirements for Type HBS govern. The default standard for brick grade is SW. This standard does include requirements for efflorescence testing the same as for ASTM C216 face brick. The discussion of compressive strength requirements under ASTM C216 also applies to hollow brick.

Color is not covered in this standard, so the specifier must designate the desired color, by specifying a proprietary product, with color and color range verified with a sample panel or mock-up panel.

ASTM C1405, Standard Specification for Glazed Brick (Single-Fired, Solid Brick Units). Most glazed brick is single-fired with a glaze that is applied during the normal firing process rather than after the unit itself is fired. ASTM C1405 covers physical requirements for the brick body and includes Grade S (select) and Grade SS (select sized or ground edge), where a high degree of mechanical perfection and minimum size variation is required. Units may be either Type I, single-faced, or Type II, double-faced. Weathering properties are specified as Exterior Class or Interior Class. Properties of the glaze and tolerances on dimension and distortion are covered as well as strength and durability requirements.

ASTM C126, Standard Specification for Ceramic Glazed Structural Clay Facing Tile, Facing Brick, and Solid Masonry Units. Double-fired glazed brick and structural clay tile are fired with clear or colored ceramic coatings to produce a matte or gloss finish. ASTM C126 covers properties of the ceramic finish including imperviousness, chemical resistance, crazing, and limitations on unit distortion and dimensional variation. Durability and weather resistance are not covered by this standard, so for exterior use, the body of glazed brick should be specified to conform to the requirements for ASTM C216 face brick, Grade SW, except with unit tolerances and surface glaze in accordance with ASTM C126. Glazed brick and tile may suffer severe freeze-thaw damage in cold climates if not adequately protected from moisture penetration, and are not recommended for copings or other horizontal surfaces in any climate. ASTM C126 covers Grade S (select) and Grade SS (select sized or ground edge), where a high degree of mechanical perfection and minimum size variation are required. When unit grade is not specified, the requirements for Grade S govern by default. Units may be either Type I, single-faced, or Type II, double-faced (opposite or adjacent faces glazed). When unit type is not specified, the requirements for Type I govern. ASTM C126 includes tests for imperviousness, chemical resistance, crazing, and opacity of the finish, and references ASTM C67 for compressive strength testing.

17.5.2 Standards for Concrete Masonry Units

ASTM C90, Standard Specification for Load-Bearing Concrete Masonry Units. Hollow and solid loadbearing concrete blocks are covered in this standard. Weight classifications are divided into Light Weight (less than 105 lb/cu ft oven dry weight of concrete), Medium Weight (105 to less than 125 lb/cu ft), and Normal Weight (125 lb/cu ft or more). Unit weight affects water absorption, sound absorption, sound transmission, and thermal and fire resistance. There are no default requirements in ASTM C90, so the specifier must designate unit type and weight classification if these properties are important to the design.

The minimum *net area* compressive strength required for all three weight classifications for ASTM C90 loadbearing units is 1900 psi. Compressive strength is largely a function of the characteristics of the aggregate used in the units, and may vary regionally according to the types of aggregates available. Aggregates in some areas may routinely produce units with much higher compressive strengths without a cost premium. If a specific unit strength requirement greater than the standard minimum is required, that compressive strength should be required by the project specifications.

Compliance with the requirements of ASTM C90 is verified by testing in accordance with ASTM C140, *Standard Method of Sampling and Testing Concrete Masonry Units*. C140 is referenced in the C90 standard and need not be listed separately in the project specification. ASTM C90 also references ASTM C33, *Standard Specification for Aggregates for Concrete*, and ASTM C331, *Lightweight Aggregates for Concrete Masonry Units*, as well as standards for the cementitious materials that are permitted in these units. It is not necessary for the specifier to list these referenced standards separately.

Size tolerances and limits on chippage and cracking are covered in the text of the standard. These requirements are more liberal than those for clay brick because of the nature of the material and the method of manufacture. For exposed architectural units such as split-face, ribbed, or ground-face units, these requirements may not be appropriate. Rough units may require greater tolerances and ground face units tighter tolerances. For such products, it may be more appropriate to consult local manufacturers for tolerance requirements. Color is not covered in this standard, so the specifier must designate the desired color by specifying a proprietary product, with color and color range verified with a sample panel or mock-up panel.

ASTM C129, Standard Specification for Non-Load-Bearing Concrete Masonry Units. The requirements of this standard are similar to those of C90 except that the units are designed for non-loadbearing applications. Unit weight classifications are the same, as well as referenced standards for aggregates, cements, sampling, and testing. Since the units are designated as non-loadbearing, the minimum requirements for net area compressive strength are lower than for ASTM C90 units at an average of only 600 psi. For typical non-loadbearing applications, this strength is more than adequate, but stronger units may be commonly available without a cost premium in some areas. Color requirements are not covered in the specification, and should be specified in the same way as that recommended for ASTM C90 units.

ASTM C55, Standard Specification for Concrete Building Brick. Concrete brick can be loadbearing or non-loadbearing. Grading is based on strength and resistance to weathering. Grade N provides "high strength and

resistance” to moisture penetration and severe frost action. Grade S has only “moderate strength and resistance” to frost action and moisture penetration. Minimum gross area compressive strength for Grade N units is 3500 psi and for Grade S units, 2500 psi. ASTM C55 does not include requirements for color, texture, weight classification, or other special features. These properties must be covered separately in the project specifications. Sampling and testing are referenced to ASTM C140, and standards for aggregates and cements are also referenced, so the specifier need not list these separately.

17.5.3 Standards for Masonry Mortar and Grout

ASTM C270, Standard Specification for Mortar for Unit Masonry. This standard covers four types of masonry mortar made from a variety of cementitious materials, including portland cement (ASTM C150), mortar cement (ASTM C1329), and masonry cement (ASTM C91), as well as blended hydraulic cement and slag cement (ASTM C595), quicklime (ASTM C5), and hydrated masonry lime (ASTM C207). These material standards are referenced in ASTM C270, so the specifier need not list them separately. If any materials are to be excluded for any reason, this should be noted in the project specifications. Requirements for mortar aggregates are referenced to ASTM C144.

Types M, S, N, and O mortar may be specified to meet either the proportion requirements or the property requirements of ASTM C270. If the project specifications do not designate which method the contractor must use, then the proportion method governs by default. The proportion method is the most conservative, and will usually produce mortars with higher compressive strengths than those required by the property method. It is generally not desirable to use mortar that is stronger in compression than the application requires. To optimize mix design, property-specified mortar requires preconstruction laboratory testing in accordance with the test methods included in ASTM C270. These test methods are not suitable for testing of field-sampled mortar during construction, and cannot be compared to the results of such tests. If field testing of mortar will be required, then *both* preconstruction and construction phase testing should be performed in accordance with ASTM C780 rather than ASTM C270. There is no test method for accurately measuring the compressive strength of hardened mortar removed from a completed masonry wall or structure.

Recommendations for appropriate use of the four basic mortar types are included in a non-mandatory Appendix X1 to ASTM C270 and are summarized in Chapter 6.

ASTM C476, Standard Specification for Grout for Masonry. This standard covers two types of masonry grout—fine and coarse. The same standards for cementitious materials are referenced as those in ASTM C270, but aggregates must conform to ASTM C404. Fine grout is used for small grout spaces and coarse grout for economy in larger grout spaces (see Chapter 6). Masonry grout may be specified to meet the proportion requirements included in the standard, or it may be required to have a minimum compressive strength of 2000 psi when sampled and tested in accordance with ASTM 1019. If higher compressive strength is required for structural masonry, the required strength should be indicated in the contract documents.

ASTM C476 permits the use of “pumping aid” admixtures in cases where the brand, quality, and quantity are approved in writing. Such admix-

tures are commonly used in high-lift grouting projects, as are certain other types of admixtures.

ASTM C1142, Standard Specification for Ready-Mixed Mortar for Unit Masonry. This standard covers four types of ready-mixed masonry mortar—RM, RS, RN, and RO. These are the equivalent of the four basic mortar types covered in ASTM C270, except that they are mixed at an off-site batching plant and delivered to the project ready to use. This standard does not include specific recommendations for use of the ready-mixed mortar types, but the recommendations in the appendix of ASTM C270 apply to these ready-mixed mortars as well (see Chapter 6). Standards for cementitious materials and aggregates are referenced in ASTM C1142 and need not be cited separately by the specifier.

17.5.4 Standards for Masonry Accessories

ASTM A36, Standard Specification for Structural Steel. This standard covers the type of steel used for angle lintels and shelf angles in masonry construction. It also applies to heavy bent bar or strap anchors that are often used to structurally connect intersecting masonry walls. Requirements for shop coating or for galvanized corrosion protection should be specified separately for this as well as any other metal accessory used in masonry.

ASTM A82, Standard Specification for Cold Drawn Steel Wire for Concrete Reinforcement. This standard covers steel wire that is used in prefabricated joint reinforcement and some types of masonry anchors and ties. It includes strength requirements and permissible variations in wire size, but does not include any options which the specifier must designate in the project documents.

ASTM A951, Joint Reinforcement for Masonry. This standard covers material properties, fabrication, test methods, and tolerances for prefabricated wire joint reinforcement for masonry. The specifier must designate corrosion protection as Brite Basic, Mill Galvanized, Class I Mill Galvanized (minimum 0.40 oz zinc per sq ft of surface area), Class III Mill Galvanized (minimum 0.80 oz zinc per sq ft of surface area), or Hot-Dipped Galvanized (minimum 1.50 oz zinc per sq ft of surface area). The hot-dip galvanizing is the same as that required for joint reinforcement under ASTM A153 as listed below and is required by code for joint reinforcement used in exterior walls.

ASTM A153, Standard Specification for Zinc Coating (Hot-Dip) on Iron or Steel Hardware. This standard covers hot-dip galvanized coatings that are required to provide corrosion resistance in exterior wall applications for masonry accessories such as steel joint reinforcement, anchors, and ties. Minimum coating weight is given in four classes based on the size and type of item being coated. Masonry accessories of various sizes are covered under Class B.

ASTM A167, Standard Specification for Stainless and Heat Resisting Chromium-Nickel Steel Plate, Sheet and Strip. This standard covers stainless steel of the type that is used for masonry anchors, ties, and flashing. There are more than two dozen types of stainless steel included in the

standard, varying according to chemical and mineral composition. Type 304 is the type most commonly used in masonry construction. Type 316 is also sometimes used in masonry.

ASTM A366, Standard Specification for Steel, Carbon, Cold-Rolled Sheet, Commercial Quality. This standard covers sheet steel of the type used for sheet metal anchors and ties used in masonry. It also covers the type of sheet metal used in masonry veneer anchors that are a combination of metal plates and wire rods.

ASTM A615, Standard Specification for Deformed and Plain Billet-Steel Bars for Concrete Reinforcement. This standard covers deformed steel reinforcing bars of the type most commonly used in reinforced concrete and reinforced masonry construction. Although there are other types that are acceptable (such as rail steel and axle steel), ASTM A615 is most prevalent in the industry. Even in unreinforced masonry projects, there may be some isolated uses of reinforcing steel such as in lintels over window and door openings.

17.5.5 Standards for Laboratory and Field Testing

ASTM C780, Standard Test Method for Preconstruction and Construction Evaluation of Mortars for Plain and Reinforced Unit Masonry. ASTM C780 covers methods for sampling and testing mortar for its plastic and hardened properties either before or during construction. If construction phase testing of mortar will be required, there must be some basis for comparison of the results of such tests. The compressive strengths and other requirements listed under the property specification of ASTM C270 or C1142 cannot be used for comparison because the test methods are different. The laboratory test methods used in ASTM C270 mix mortar samples with a relatively low water-cement ratio. Field-mixed mortars, however, use much higher water-cement ratios in order to overcome the initial absorption of the masonry units. When compared with one another, the field-mixed mortars would appear to be much weaker than the C270 test results. To provide an “apples-to-apples” comparison, the preconstruction design mix must also be tested with a high water-cement ratio to simulate that which will actually be prepared during construction. Using ASTM C780 to obtain a preconstruction benchmark for the mortar provides a basis for acceptance or rejection of field-sampled mortars during construction.

ASTM C1019, Standard Test Method for Sampling and Testing Grout. This standard covers both field and laboratory sampling for compressive strength testing of masonry grout. This standard should be referenced in the project specifications for loadbearing masonry construction if the compressive strength of the masonry construction is to be verified by either the unit strength method or prism test method.

ASTM C1314, Standard Test Method for Constructing and Testing Masonry Prisms Used to Determine Compliance with Specified Compressive Strength of Masonry. In structural masonry projects, the engineer must indicate on the drawings the required compressive strength of masonry (f'_m) on which the design is based. The contractor must verify to the engineer that the construction will achieve this minimum compressive

strength. This verification may be provided in one of two ways—the unit strength method or the prism test method. The unit strength method is very conservative, and is based on the empirical assumption that the combination of certain mortar types with units of a certain compressive strength will produce masonry of a given strength. If the manufacturer submits certification of the unit compressive strength and the mortar is specified by the ASTM C270 proportion method, compressive strength verification can be provided by a table in the code without any preconstruction or construction testing of any kind. If the mortar was specified by the ASTM C270 property method, the mortar test discussed above, along with the manufacturer's certification of unit strength, is sufficient to verify compressive strength compliance. If f'_m must be verified by the prism test method, an assemblage of the selected units and mortar must be constructed and tested in accordance with ASTM C1314. This test may be used both for preconstruction and construction evaluation of the masonry. Although the ASTM C1314 test method is similar to other compressive strength test methods, ASTM C1314 does not require any extraneous information other than that required for verification of the specified compressive strength.

17.6 MASONRY SUBMITTALS

Submittals are a time-consuming, but important, part of construction projects. Submittals are used to help assure that the work meets the requirements of the contract documents and that the contractor achieves the standard of quality established by the specifications. For each project, the architect or engineer must decide what submittals are needed for each portion of the work. Submittals require time and money to prepare and process (for both the A/E and the contractor), so it is important that only those submittals that are appropriate and necessary to the work be required.

The types of submittals that are appropriate or necessary will vary from project to project according to the nature of the construction, both aesthetic and structural. For masonry projects designed under the Masonry Standards Joint Committee (MSJC) *Building Code Requirements for Masonry Structures (ACI 530/ASCE 5/TMS 402)*, some submittals are mandatory. Projects that are non-structural, but aesthetically important, may lean more toward submittal of unit and mortar samples than test reports. Each project is unique in its requirements.

17.6.1 Specifying Submittals

According to the *CSI Manual of Practice*, administrative and procedural requirements for submittals should be specified in Division 1—General Requirements, because they apply to all project submittals. CSI's MasterFormat™ designates Section 01300 as the proper location for these requirements, which would include information such as the number of copies required, how much time should be allowed for review, and to whom reviewed submittals should be distributed.

Specific submittals required for a masonry project should be specified in the appropriate technical section in Division 4. Each of the technical sections should include in Part 1 a complete list of the submittals required for that portion of the work. Submittals may include shop drawings, product data, samples, and quality assurance/quality control submittals. Each type of submittal has a different function, and is applicable to different types of materials, products, or systems. *Figure 17-3* lists all of the types of submittals and

<p>SHOP DRAWINGS</p> <ul style="list-style-type: none">• fabrication dimensions and placement locations for reinforcing steel and accessories• sheet metal flashing details• stone fabrication and setting drawings <p>PRODUCT DATA</p> <ul style="list-style-type: none">• proprietary mortar ingredients<ul style="list-style-type: none">• portland cement• masonry cement• mortar cement• lime• admixtures (including pigments)• connectors• joint reinforcement• flashing materials• weephole and drainage accessories• cleaning agents <p>SAMPLES</p> <ul style="list-style-type: none">• masonry units• stone• mortar colors• connectors• flashing materials• accessories <p>QUALITY ASSURANCE / QUALITY CONTROL SUBMITTALS</p> <ul style="list-style-type: none">• design data<ul style="list-style-type: none">• mortar mix designs (property specification only)• grout mix designs (for required compressive strength only)• test reports<ul style="list-style-type: none">• prism test (alternate method of verifying f'_m)• preconstruction testing• field testing• certifications<ul style="list-style-type: none">• compliance with specified ASTM standards• brick IRA• inspection reports<ul style="list-style-type: none">• materials• construction procedures• reinforcement• grouting• protection measures• manufacturer's instructions<ul style="list-style-type: none">• mortar admixtures• mortar pigments• cleaning agents• manufacturer's field reports<ul style="list-style-type: none">• cleaning operations• proposed hot and/or cold weather construction procedures
--

Figure 17-3 Masonry submittals checklist.

submittal information that might be included in a masonry specification. The list will vary as appropriate to the project, the type of construction, and the wishes of the architect or engineer.

17.6.2 Submittal Procedures

Submittals must be reviewed and approved before construction can begin. Material and equipment cannot be ordered or fabricated until specified submittals are approved by both the contractor and the A/E. The general contractor is responsible for submitting required information to the A/E for review and approval. Many of the required submittals may actually be prepared by subcontractors, suppliers, fabricators, or manufacturers. The general contractor must check all submittals, stamp and sign them, assemble them with transmittal forms, and submit them to the A/E for review. Submittals that are not approved must be resubmitted with the required changes, reviewed, and approved before construction can begin. Both the A/E and the contractor should maintain a submittal log to track the progress of all project submittals. A copy of all approved submittals should be kept with the record documents at the job site until the project is complete. Both the A/E and the contractor usually retain copies of approved submittals as part of their permanent project records.

In masonry construction, it is the responsibility of the masonry subcontractor to prepare or assemble the required masonry submittals and turn them over to the general contractor. Manufacturer's literature on masonry accessories, product certifications on masonry units, or metal flashing details, may sometimes be prepared by the supplier, manufacturer, or fabricator, respectively, for submittal by the masonry subcontractor to the general contractor.

17.6.3 Shop Drawings

Shop drawings are prepared to illustrate some details of the construction. They are typically prepared by a manufacturer or fabricator for use in producing items, and as an aid to the contractor in coordinating the work with adjacent construction.

For example, structural engineering drawings typically show reinforcing steel only diagrammatically in plans and sections. The shop drawings show each size, dimension, and type of rebar and its configuration and splice details, as well as a key to its plan location and the quantity required. These drawings are used then in the steel fabricator's shop to prepare the individual elements needed at the project site. The engineer reviews the shop drawings for conformance to design and contract document requirements, but does not generally check the quantities. Projects under the jurisdiction of the MSJC Code are required to have shop drawings for structural reinforcing steel.

The A/E may also wish to have shop drawings submitted to illustrate metal flashing details such as end dams, corners, lap seals, and abutments with other construction. These drawings can then be used to fabricate the required flashing sections in the sheet metal shop for installation at the project site by the masons. Requiring shop drawings for flashing can help assure that the contractor has anticipated and planned for all field installation conditions and has properly interpreted the drawing and specification requirements.

Loose steel angle lintels and prefabricated concrete lintels should require the submittal of shop drawings for verification of dimensions and coordination with masonry coursing. Projects with cut stone may have exten-

sive shop drawings that identify each size and shape of stone, its anchorage conditions, and placement location. In grouted construction, the engineer may also require shop drawings showing the type of temporary construction that will be used to brace uncompleted walls.

17.6.4 Product Data

Fabricated products such as the accessories used in masonry construction typically require the submittal of manufacturers' product data rather than shop drawings. Many specifications list the products of several different manufacturers that are acceptable for use in the construction. Others specify products only by description or by reference standard without mentioning proprietary names. These methods of specifying make it necessary to require the submittal of proprietary product data to verify that the products that the contractor proposes to use meet the specified requirements. Masonry product data might include catalog sheets or brochures for anchors, ties, rebar positioners, joint reinforcement, weep-hole ventilators, and shear keys. The masonry contractor or supplier who prepares the submittal should mark data sheets that include more than one item to clearly show which item or items are proposed for use. If there are various model numbers, materials, sizes, etc., these too should be marked to show the appropriate selection.

Manufactured products such as cement, admixtures, mortar coloring pigments, and cleaning agents may also be included in the A/E's list of required submittals. If more than one brand of proprietary masonry cement or mortar cement is approved for use on the project, the manufacturer's product literature should be submitted to indicate which particular products the contractor is proposing to use, and to verify their conformance to contract document requirements. Product data on approved types of admixtures should clearly indicate the chemical ingredients included to assure that they contain no calcium chloride or other harmful substances. Product data on mortar coloring pigments and proprietary cleaning agents other than hydrochloric acids or detergents should also be submitted for review and approval.

17.6.5 Samples

Samples may be required for masonry units, colored mortars, and some selected accessory items. Unit samples are most often reviewed for color selection purposes during earlier design phases, but if the masonry has been specified on a unit price basis, or only by ASTM reference standard, the A/E must approve samples submitted by the contractor. Cut stone, brick, and architectural CMU samples should indicate the full range of color, texture, shape, and size. Any project requirements for sample panels or mock-ups should be specified under the quality assurance article of Part 1 rather than under this article, which is reserved for individual unit or material samples.

17.6.6 Quality Assurance/Quality Control Submittals

Quality assurance and quality control submittals include test reports, manufacturer's or contractor's certifications, and other documentary data. These submittals are usually for information only. They are processed in the same manner as shop drawings and product data, but do not always require review and approval.

If mortar is specified by ASTM C270 property requirements for compressive strength rather than the default proportion specification, mix *design data* should be submitted for review, along with the results of *preconstruction tests* verifying compliance with the required compressive strength. Grout mixes that are required to attain a specified compressive strength should also require mix design and test result submittals. The results of preconstruction tests must be available for comparison with the results of any *field tests* that may be required, because they are the only valid criteria against which field test results can be compared. For structural masonry projects on which the contractor chooses to verify the strength of masonry by *prism tests*, these results should also be submitted.

The A/E may sometimes require that a manufacturer or fabricator perform testing of a specific product lot, run, shipment, etc. For example, masonry unit manufacturers might be required to submit test results verifying compliance with specified properties such as compressive strength or absorption. For structural masonry projects on which the contractor chooses to verify the strength of masonry by the unit strength method, these unit strength test results should be compared to minimum requirements listed in the code tables. This type of submittal is called a *source quality control submittal*.

Instead of laboratory test results, some products may be submitted with written *certification* from the manufacturer that the item complies with specified requirements. Certifications are usually in the form of a letter, and require the signature of an authorized company representative. The MSJC Specifications require that in addition to reinforcing steel shop drawings, certifications of compliance be submitted for each type and size of reinforcement, anchor, tie, and metal accessory to be used in the construction. Certification of unit, mortar, and grout materials may also be required instead of test results for some projects that do not involve structural masonry elements.

On projects where field inspection is provided by someone other than the project engineer, the specifications should require submittal of *inspection reports* on materials, protection measures, construction procedures, reinforcing steel placement, and grouting operations. If the project engineer is doing field inspections, the same type of information may be kept on file as field notes.

For some products such as cleaning agents or mortar coloring pigments, the A/E may require submittal of *manufacturer's instructions* for application, mixing, or handling of materials. Hazardous materials should require submittal of material safety data sheets (MSDS). *Manufacturer's field reports* are also sometimes required if the A/E wants to verify that a representative of the cleaning agent manufacturer, for instance, has visited the project site to inspect substrate conditions or to instruct the contractor in the application of certain materials or cleaning methods.

Finally, the A/E may require the submittal of proposed *hot and/or cold weather construction procedures* to meet the requirements stipulated by the MSJC Code and Specifications. The contractor's submittal should describe the specific methods and procedures proposed to be used to meet these requirements.

17.6.7 Closeout Submittals

Closeout submittals include such things as record documents, extended warranty information, maintenance instructions, operating manuals, and spare

parts. Masonry construction does not usually involve this type of documentation. If coatings or clear water repellents are used to reduce the surface absorption of the masonry, and if those materials carry a manufacturer's extended warranty, the information would be submitted by the applicator of the material rather than by the masonry contractor.

17.7 SAMPLE PANELS AND MOCK-UPS

Sample panels and mock-ups are an important part of quality assurance programs. They can also be an effective tool of communication between the design office and the job site in setting both technical and more qualitative aesthetic standards. For aesthetic criteria, sample and mock-up panels are the *only* practical and effective method of establishing a fair and equitable procedure for evaluating the completed work. For technical criteria, mock-ups provide a well-defined yardstick for measuring performance without dispute.

17.7.1 Sample Panel

A sample panel is defined as a site-constructed panel of masonry to be used as a basis of judgment for *aesthetic* approval of the appearance of the materials and workmanship (see Fig. 17-4). Sample panels should not routinely be used to make design decisions on color, bond pattern, or joint type unless the work of constructing multiple sample panels has been contracted separately from the project construction based on a unit price per panel. Color matching masonry on renovation or rehabilitation projects may require numerous panels to make such decisions. Design panels should be constructed very early to allow time for procurement of the selected materials.

17.7.2 Mock-Up

A mock-up is more than just the units and mortar of the traditional masonry sample panel. Mock-ups also incorporate other elements of the project masonry including, as appropriate, backing wall, reinforcing steel, shelf angles or supports, ties or anchors, joint reinforcement, flashing, weep holes, and control or expansion joints (see Fig. 17-5). Design elements such as windows or parapets that may be considered critical aesthetically or from a per-



Figure 17-4 Traditional masonry sample panels for evaluating unit color, color range, mortar color, joint tooling, and general workmanship.



Figure 17-5 Masonry mock-ups should include all elements important to the performance and appearance of the masonry such as backing wall, anchors, drainage mat, flashing, weeps, movement joints, and windows.

formance standpoint can also be incorporated at the discretion of the architect or engineer.

Mock-ups should be used instead of sample panels whenever the acceptability of the masonry will be judged on more than just finished appearance, and construction observation or inspection will be provided to verify conformance. Mock-ups can be used not only to verify size, chippage, and warpage tolerances of units, but also to establish aesthetic criteria such as unit placement, joint tooling, joint color uniformity, and the even distribution or blending of different color units or units with noticeable color variations. Because they incorporate other elements, however, mock-ups are perhaps most valuable for establishing acceptable workmanship and procedural requirements for such items as placement of reinforcement, embedment of connectors, installation of flashing, and prevention of mortar droppings in wall cavities.

Since many of the items required in the mock-up will be concealed, and since acceptance may be based on procedure as well as appearance, the architect or engineer should try to be present during construction of the panel to observe the work and to answer questions about specified requirements. Documentation of concealed elements and procedural items may best be accomplished by photographing the work in progress. A cursory examination of a completed mock-up panel will tell the observer nothing about what's inside the wall (or isn't inside the wall). Acceptance on such a basis does not give adequate criteria on which to accept or reject the project masonry. The proper evaluation and comparison of the project masonry with the standards of the mock-up require on-site observation or inspection by the architect, engineer, or independent inspector. The person who will evaluate and accept or reject the work, if different from the design architect or engineer, should also be present for construction of the mock-up. Depending on its size, construction of the mock-up could be incorporated into a preconstruction conference. Both the meeting and the mock-up can be instrumental in clarifying

project requirements, understanding design intent, and resolving potential problems or conflicts.

The mock-up should be constructed by a mason or masons whose work is typical of that which will be provided in the project, because it establishes the standard of workmanship by which the balance of the masonry will be judged.

17.7.3 Grout Demonstration Panel

The MSJC Code and Specifications stipulate certain requirements for grout space geometry, grouting procedures, and construction techniques. Projects that use alternative methods or exceed the code limitations should require construction of a grout demonstration panel to determine the effectiveness of those methods.

18

SPECIFICATIONS AND FIELD OBSERVATION

The quality, durability, and cost effectiveness of masonry systems are affected by decisions made throughout the design and documentation phases, and by field observation and inspection practices. Project specifications establish standards of quality, which should be strictly enforced to ensure structural integrity, weather resistance, and long service.

18.1 ECONOMIC CONSIDERATIONS

Exterior envelope materials are usually selected on the basis of both cost and aesthetics. An architect or building owner may begin with a mental image of the project that is related to its context, its corporate identity, and its budget. Masonry is very cost-competitive as an envelope material, but the decision to use masonry of one type or another is usually an aesthetic one. Material selections are based on color, texture, and scale.

The relative cost of different types of brick or different types of architectural block is related primarily to unit size and labor production. Typical union production rates for several types of brick and block are listed in *Fig. 18-1*. Within a selected size, however, aesthetic preference should govern unit selections, because the cost of materials has only a small effect on the cost of the completed envelope. According to one study, doubling the cost of brick added less than \$2.00/sq ft to the wall cost. There are a number of other design and specification decisions that affect masonry cost and can be used to minimize budget limitations.

18.1.1 Factors Affecting Cost

Careful detailing and thoughtful design can enhance the cost economy of any building system. Conscientious planning and material selection, attention to detail, thorough specifications, and on-site field observation and inspection can all contribute to lower masonry costs. In masonry construction, unit size,

Mason Productivity				
Description	Unit Weight (lb.)	Unit Surface Area (sq.ft.)	Productivity (sq.ft/8 hr.)	Relative Productivity
4 x 2-2/3 x 8 standard brick	—	0.148	160	1.00
4 x 2-2/3 x 12 norman brick	—	0.222	207	1.28
4 x 4 x 8 economy brick	—	0.222	218	1.36
4 x 4 x 12 king size brick	—	0.333	242	1.51
12 x 8 x 16 hollow CMU	31.9	0.889	376	2.35
8 x 8 x 16 hollow CMU	26.2	0.889	467	2.92
4 x 8 x 16 hollow CMU	16.4	0.889	494	3.09
6 x 8 x 16 hollow CMU	21.1	0.889	526	3.29
8 x 8 x 24	normal weight 130 pcf concrete	1.333	696	4.35
8 x 8 x 24	lightweight 96 pcf concrete	1.333	786	4.91

Figure 18-1 Mason productivity varies with unit size. (From *NMCA TEK Bulletin 54 and NMCA Research and Development Laboratory, "Research Investigation of Mason Productivity,"* Masonry, May/June 1989.)

unit weight, and modular dimensions have as much or more influence on mason productivity (and therefore on cost) than any other factors.

- Larger-face-size units increase the area of wall completed each day, even though the mason may lay fewer units because of greater weight. This option is simple and cost-effective. The higher price of larger units can be offset by lower labor costs and by earlier completion of the work. For some designs, larger masonry units may actually give better proportional scale with the size of the building as well.
- All other factors being equal, mason productivity decreases as unit weight increases (see *Fig. 18-2*). Selection of unit weight (normal, medium, or lightweight) should be matched to project requirements for thermal resistance, fire resistance, water penetration resistance, and loadbearing capacity.
- Running bond patterns generally increase mason productivity, while decorative patterns and even stack bond patterns decrease productivity.
- Colored mortar costs more than ordinary gray mortar.
- Proper planning with modular dimensions increases productivity and reduces cost.
- Analytically designed brick or CMU curtainwalls can eliminate the need for shelf angles on buildings up to 100 ft or more in height.
- Mechanical and electrical lines and conduit are less expensive to place in double-wythe cavity walls than in single-wythe walls unless special concrete block units are used.
- Openings spanned with masonry arches or reinforced masonry lintels eliminate the need for steel angle lintels and the associated maintenance costs they include.

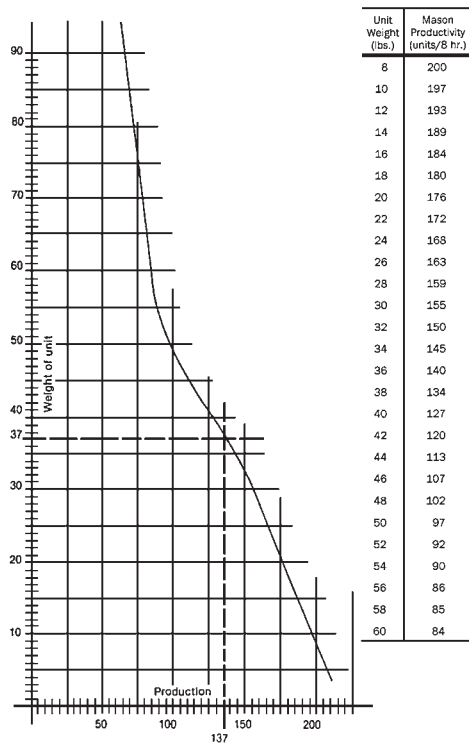


Figure 18-2 Estimated productivity rates based on weight of masonry units. (From Kolkoski, *Masonry Estimating*.)

18.1.2 Value Engineering

In estimating the total cost of a building system or product, future as well as present costs must be considered. Value engineering and life-cycle costing methods evaluate expenses throughout the life of a building. For example, the fire resistance of masonry structures means lower insurance rates and lower repair costs if interior spaces do sustain damage from fire (refer to Chapter 8). Masonry thermal characteristics reduce energy consumption for heating and air conditioning, and the durability and finish of the surfaces also minimize maintenance costs.

Maximizing the structural and functional capabilities of the masonry will also reduce initial costs. Strength design of reinforced masonry permits construction of tall, slender walls with significant reductions in lateral support requirements. Using double-wythe walls for loadbearing applications multiplies their functional role to that of structure, acoustic and fire separation, mechanical and electrical chase, exterior envelope, and interior finish.

But “value” engineering can *devalue* a building if initial costs of critical items are cut without regard to performance or maintenance issues. It makes little sense, for instance, to save a few dollars of initial cost by switching to a less expensive (i.e., less durable) flashing material. Stainless steel flashing may not be warranted on the corner convenience store that will undoubtedly be gone in a few years, but PVC flashing is just as inappropriate on a courthouse or school or other public building likely to be occupied for decades.

18.2 SPECIFICATION GUIDELINES

Specifications are an important part of quality assurance and quality control in masonry construction. To achieve quality workmanship and proper performance, the architect or engineer must carefully outline the products and standards of construction required. Reference standards should be used to govern the quality of specified products. ASTM standards cover all of the mortars, unit types, and varieties of stone (see Appendix B), and are widely accepted throughout the industry.

Lump-sum or unit-price allowances may be used for specifying masonry units, but the specifications should also include sufficient information (including unit size, grade, type, and texture) so that the contractor can accurately bid the labor required for installation. Most ASTM standards for masonry products cover two or more grades and types of units, so the project specifications must identify what is required. Omitting this information makes it impossible for bidders to accurately estimate cost.

The size of unit required should always be included in the specifications, preferably giving actual rather than nominal dimensions to avoid ambiguity. In some industries, “nominal” means approximate, but in modular masonry, it means the manufactured dimension plus the thickness of the mortar joint. A nominal 8-in. modular brick can be manufactured at $7\frac{1}{2}$ in. for use with $\frac{1}{2}$ -in. joints, or $7\frac{5}{8}$ in. for use with $\frac{3}{8}$ -in. joints. Dimensions should be listed with thickness first, followed by the face dimensions of height and then length.

Color and texture are not included in ASTM standards, so requirements must be established by the specifications. If an allowance method is used, the final selection may be made from samples submitted by the contractor or supplier. If trade names are used to identify a color range and finish, or if descriptions are not given in the project specifications, samples of acceptable materials should be available to the contractors for inspection prior to bidding.

The specification guidelines that follow may be used as a reminder list for the primary items requiring attention in the specifications. If more than one masonry system is used on a project, sections should be combined to include the mortar, units, and accessories for each system under a separate heading (e.g., Veneer Masonry System or Reinforced Unit Masonry System). This makes it clear to the contractor which anchors or ties go where, what mortar type, flashing, and so on.

18.2.1 Mortar and Grout

- Portland cement: ASTM C150 Type I, or Type III for cold weather, low alkali content, non-staining

- Masonry cement: ASTM C91 (list acceptable manufacturers)
- Mortar cement: ASTM C1329 (list acceptable manufacturers)
- Hydrated lime: ASTM C207, Type S
- Sand: ASTM C144, clean and washed
- Grout aggregates: ASTM C404
- Water: clean and potable
- Admixtures: no calcium chloride permitted (list others permitted or prohibited)
- Mortar type: ASTM C270, Type (M, S, N, O, or K), proportion specification (default), or property specifications (minimum compressive strength for structural masonry)
- Grout type: ASTM C476 (fine or coarse)

18.2.2 Masonry Accessories

- Metals:
 - Cold-drawn steel wire, ASTM A82
 - Welded steel wire fabric, ASTM A185 or A497
 - Sheet metal, ASTM A366
 - Plate, headed, and bent bar ties, ASTM A36
- Reinforcing steel:
 - Billet steel deformed bars, ASTM A615
 - Rail steel deformed bars, ASTM A616
 - Axle steel deformed bars, ASTM A617
- Corrosion protection:
 - Stainless steel, ASTM A167, Type 304
 - Hot-dip galvanized steel, ASTM A153, Class B
- Masonry ties: manufacturer, model number, type of metal
- Veneer anchors: manufacturer, model number, type of metal
- Fasteners: list appropriate types
- Joint reinforcement: ASTM A951, wire gauge, type (ladder or truss), corrosion protection (see above)
- Accessories: through-wall flashing, weep-hole accessories, drainage accessories, control joint shear keys, compressible expansion joint filler, cleaning agents

18.2.3 Masonry Units

- Facing brick: ASTM C216, Grade (MW or SW), Type (FBX, FBS, or FBA), unit size, color and texture, manufacturer, minimum compressive strength
- Glazed brick: ASTM C1405, Class (exterior or interior), Grade (S or SS), Type (I or II), unit size, color and texture, manufacturer, minimum compressive strength
- Building brick: ASTM C62, Grade (SW, MW, or NW), unit size, minimum compressive strength
- Hollow brick: ASTM C652, Grade (SW or MW), Type (HBX, HBS, HBA, or HBB), unit size, color and texture, manufacturer, minimum compressive strength

- Hollow or solid loadbearing CMU: ASTM C90, weight (normal, medium, or light), unit size, color and texture (architectural block only), minimum compressive strength
- Non-loadbearing CMU: ASTM C129, weight (normal, medium, or light), unit size, color and texture (architectural block only), minimum compressive strength
- Concrete brick: ASTM C55, Grade (N or S), weight (normal or light), unit size, color and texture, manufacturer, minimum compressive strength

18.2.4 Construction

- Preconstruction conference
- Submittals, sample panels, mock-ups, testing
- Storage and protection of materials, hot and cold weather protection procedures
- Tolerances for placement and alignment of masonry
- Mortar mixing, retempering, placement, joint tooling, and pointing
- Wetting of brick with high IRA, unit blending, unit placement
- Installation of flashing and weep holes, connectors, joint reinforcement, control joints, and/or expansion joints
- Placing reinforcement, grouting methods
- Temporary bracing and shoring, protection during construction, protection of finished work, moist curing

18.2.5 Quality Control Tests

Laboratory testing of materials and assemblages is usually limited to structural masonry rather than veneer systems. Mortar, grout, and masonry prisms may all be tested before construction to establish quality standards, and tested during construction to verify compliance (refer to Chapter 17). Tests may also be used as part of the material selection process.

When mortar is specified to have a certain minimum compressive strength for structural masonry, it is required to meet the property specification of ASTM C270 rather than the default proportion specification. To verify that the contractor's proposed mortar mix meets the strength requirements, a sample can be tested in accordance with ASTM C270, but the results will not be comparable for testing later field samples, because the methods of preparing the lab sample are not the same as those used in the field. If subsequent testing of field samples will also be required, both preconstruction and construction testing should be done in accordance with ASTM C780, *Standard Test Method for Preconstruction and Construction Evaluation of Mortars for Plain and Reinforced Unit Masonry*. The preconstruction test sets a quality standard against which field-tested samples may be compared. ASTM C780 actually includes several different types of tests, including compressive strength, board life, mortar-aggregate ratio, water content, air content, and tensile strength. Specify only those tests that are needed.

Grout testing before and during construction can be done by a single test, ASTM C1019, *Standard Method of Sampling and Testing Grout*, which applies to both laboratory-prepared and field-prepared samples.

The compressive strength (f'_m) of structural masonry may be verified by the unit strength method or by the prism test method (refer to Chapter 12).

If f'_m must be verified by the prism test method rather than the unit strength method, an assemblage of the selected units and mortar must be constructed and tested in accordance with ASTM C1314, *Standard Test Method for Constructing and Testing Masonry Prisms Used to Determine Compliance with Specified Compressive Strength of Masonry*. This test may be used both for preconstruction and construction evaluation of the masonry.

18.2.6 Sample Panels and Mock-Ups

A sample panel is defined as a site-constructed panel of masonry to be used as a basis of judgment for *aesthetic* approval of the appearance of the materials and workmanship. Judging the appearance of masonry can be very subjective, but there are several basic things that should be considered:

- Compliance with allowable unit chippage and warpage
- Compliance with allowable size tolerances
- Unit placement
- Mortar joints and tooling
- Overall workmanship

Typical sample panels range in size from 4 ft × 4 ft to 4 ft × 6 ft or larger. The Masonry Standards Joint Committee (MSJC) *Specification for Masonry Structures* (ACI 530.1/ASCE 6/TMS 602) requires a minimum sample panel size of 4 ft × 4 ft. Larger panels which incorporate technical as well as aesthetic criteria can be more effective in establishing project standards.

A mock-up panel goes a step beyond the sample panel because it includes other elements of the work not related to aesthetics (refer to Chapter 17). Mock-ups may be required instead of or in addition to sample panels. They may serve the dual purpose of setting criteria for both aesthetic and technical consideration, and they may also be built for testing purposes. Mock-ups should include all of the basic components of the masonry system and backing wall, including reinforcement, connectors, shelf angles, flashing, weep holes, and expansion and control joints. If more elaborate mock-ups are required to show specific areas or details of the work such as window detailing, the panels should be delineated on the drawings or described adequately in the specifications to clearly identify the work required. Mock-up panels are often larger than sample panels. The size will vary with complexity, but a basic panel without a window element or other special components should be at least 4 ft × 6 ft.

Sample panels and mock-ups can be built free-standing or as part of the permanent construction. If free-standing, they should be located where they will not interfere with subsequent construction or other job-site activities because they must remain in place until the masonry work has been completed and accepted. Sample panels and mock-ups should be constructed early enough in the construction schedule to allow for rejection and reconstruction without delay to the work.

Since many of the items required in a mock-up will be concealed, and since acceptance is based on procedure as well as appearance, the architect or engineer should try to be present during construction of the panel to observe the work. Documentation of concealed elements and procedural items may best be accomplished by photographing the work in progress. A cursory examination of a completed mock-up panel will tell the observer

nothing about what's inside the wall (or isn't inside the wall). Acceptance on such a basis does not give adequate criteria on which to accept or reject the project masonry.

Specifications typically say too little about sample panels and mock-ups. The construction documents should allow bidders to accurately estimate the cost of constructing the mock-up. Size and number of panels required and all of the components to be included should be specified. Complex mock-ups that include various design elements should be illustrated on the drawings in plan, elevation, and section, and referenced to specific project details. The specifications should designate the accepted mock-up as the project standard. They should also clearly establish the aesthetic and technical criteria on which acceptance or rejection of the panel will be based, as well as the person who will be responsible for evaluation (i.e., architect, engineer, construction manager, independent inspector, owner, etc.). Only specified products and materials or accepted substitutes should be used to construct the mock-up. Units should be of the same production run that will be supplied for the project, and should represent the full range of color variation to be expected in the project. Mortar ingredients, including sand and water, should also be those that will be used for project construction, since they have a significant effect on mortar color. The specification should also stipulate that the panel be built by a mason whose work is typical of that to be expected in the finished wall. A mason contractor would not be wise to assign the best available bricklayer to build the sample, because if the rest of the crew cannot match that workmanship, there may be a basis for rejection of the finished work. Before construction of a sample panel or mock-up begins, all project submittals should be reviewed for conformance to contract document requirements, and any required preconstruction testing should be complete.

18.3 SPECIFYING WITH THE MSJC CODE

The *International Building Code* requirements for masonry construction are based primarily on the Masonry Standards Joint Committee (MSJC) *Building Code Requirements for Masonry Structures* (ACI 530/ASCE 5/TMS 402), which is jointly written by the American Concrete Institute (ACI), the American Society of Civil Engineers (ASCE), and The Masonry Society (TMS). IBC 2000 is based on the 1999 MSJC Code and IBC 2003 is based on the 2002 MSJC Code. Both editions of the MSJC Code incorporate ACI 530.1/ASCE 6/TMS 602, *Specification for Masonry Structures*, as part of the Code.

The MSJC Specifications establish a minimum quality standard for materials and construction, and attempt to ensure a level of testing and inspection commensurate with that required for concrete and steel structures. The document, however, must be coordinated with individual project specifications to avoid overlaps, duplications, conflicts, and omissions.

The MSJC Specifications are intended to be "modified and referenced" in the project specifications. Individual sections, articles, or paragraphs should not be copied into the project specifications, since taking them out of context may change their meaning. A statement such as the following will serve to incorporate the standard into the project spec.

Masonry construction and materials shall conform to requirements of the Masonry Standards Joint Committee *Specification for Masonry Structures* (ACI 530.1/ASCE 6/TMS 602) except as modified by this Section.

The project specifications may stipulate more stringent requirements. They must supplement the MSJC Specifications in order to customize their application to each particular project and design.

The MSJC Specifications are not written as a guide specification with instructions or recommendations to the specifier. There is a commentary published with the Code and the Specifications, which gives some background information and suggestions on using the standards. A much more comprehensive handbook has been written by The Masonry Society, entitled the *Masonry Designers' Guide Based on Building Code Requirements for Masonry Structures* (ACI 530/ASCE 5/TMS 402) and *Specification for Masonry Structures* (ACI 530.1/ASCE 6/TMS 602). A *Masonry Designers Guide* has been published for each edition of the Code and Specification published. The MSJC Specification also includes a checklist of mandatory items to which the specifier must respond, and a checklist of optional items where methods and materials other than the standard requirements may be specified. Items required in addition to the MSJC Specifications must also be addressed in the project specifications. The MSJC Specifications must be well coordinated with the project specifications (including Division 1 requirements) to avoid overlaps, duplications, conflicts, and omissions.

The Code mandates use of the MSJC Specifications, and at the same time states that the MSJC Specifications do not govern where different provisions are specified. This allows the specifier to alter requirements through the project specifications. While the intent is to permit the project specification to impose more stringent requirements, it is equally possible that less stringent requirements could be specified, and these would take precedence over the MSJC Specifications.

The Masonry Society's *Annotated Guide to Masonry Specifications* is the best resource available for detailed description and discussion of typical masonry specification requirements. It is based on the MSJC Code and Specification and is intended to guide the specifier through the many decisions required in compiling masonry project specifications. The following discussion is intended to provide general guidance on preparing project specifications which must be coordinated with the MSJC Specification. Topics are listed in the order in which they appear in CSI's SectionFormat™.

18.3.1 General

References. The correct title, document number, issuing body, and date of the MSJC Specification should be given in the list of references. The MSJC Specification includes a list of ASTM references, which should be checked for conflicts and omissions. The mandatory checklist then requires that sections, parts, and articles of the MSJC Specifications excluded from the project specs be indicated, and articles at variance with the project specifications be listed. This list will vary for each project.

Quality assurance. The checklists use the term "quality assurance" ambiguously to indicate both construction submittals, inspection, and preconstruction testing. The mandatory checklist asks that the specifier define the submittal reporting and review procedure, which should be the same as requirements outlined in Division 1 of the project specifications. The mandatory checklist also requires that the specifier designate the quality assurance level appropriate to the project (refer to Chapter 17 for a discussion of MSJC Level 1, Level 2, and Level 3 quality assurance). The level of quality assurance designated includes minimum requirements for testing, submittals, and inspection. Check the articles on inspection agency and testing agency services and duties for conflicts with Division 1 requirements.

Loadbearing masonry. The mandatory checklist requires that the specifier designate when grout strength must be verified by test.

18.3.2 Products

Materials. The mandatory checklist contains a number of product-related items. The MSJC Specification lists all of the ASTM clay, concrete, and stone masonry unit and material standards that are applicable to structural masonry systems. The specifier must indicate which units will be used and specify the required grade, type, size, and color as applicable. Mortar and grout ingredients must be specified, including any acceptable admixtures. The type and grade of reinforcement are required by the MSJC Code to be shown on the drawings, and by the MSJC Specifications to be given in the project specs. Wire fabric, if used, must be designated as either smooth or deformed. While the Specification does list ASTM requirements for the materials used for anchors and ties, it does not specify the anchors and ties themselves. The exact types and sizes required for the project, including any proprietary products, must be given in the project specifications.

Although the Code includes design requirements for masonry veneers, only passing reference is made to flashing and weep holes. The MSJC Specifications do not include material or installation requirements for these items, so flashing and weep holes must still be covered in the project specifications. All required accessories, including flashing and weep-hole materials, must be specified, as well as the size and shape of joint fillers, and the size and spacing of pipes and conduits to be furnished and installed by the mason. If prefabricated masonry elements are used, specify any requirements supplemental to ASTM C901, *Standard Specification for Prefabricated Masonry Panels*.

The optional checklist includes requirements to specify if acid cleaners are permitted.

Mixes. Specify grout requirements at variance with the MSJC Specification.

18.3.3 Execution

Preparation. The optional checklist asks the specifier to note when wetting of the masonry units is required to ensure good bond between units and mortar. However, the wording in the Specification itself prescribes these limits correctly as high-suction clay masonry units with initial rates of absorption in excess of 1 g/min/sq in., when tested in accordance with ASTM C67, *Standard Method of Sampling and Testing Brick and Structural Clay Tile*. The specifier should indicate, though, when tests are required, whether suction tests are to be laboratory or field conducted, and the method of wetting to be used when it is determined necessary. Units should not be wetted when the initial rate of absorption is acceptable, nor during winter construction.

Installation. There are several items on the optional checklist that apply to installation of the masonry. The specifier must indicate, first of all, if the pattern of units in the project is anything other than one-half running bond, and if the joints are other than $\frac{3}{8}$ inch. Collar joints $\frac{3}{4}$ in. wide or less are to be solidly filled with mortar unless otherwise required

by the project specs. Face shell bedding of hollow units also governs except in piers, columns, pilasters, starting courses at the foundation, and at grouted cells or cavities, where cross webs must also be mortared. If there are other locations that require full mortar bedding, these should be identified in the project specification. Variations from the standard full bedding requirements for solid units should also be noted, such as beveling to minimize mortar droppings in the cavity. The location of embedded sleeves for pipes and conduits should be shown on the drawings, and only the requirements for their installation covered in the specifications. Requirements for the size and spacing of both rigid and adjustable wall ties, if different from those in the specification, should be given. The location and types of movement of joints are required to be indicated on the drawings.

The construction tolerances listed in the MSJC Specifications are structural tolerances intended to limit the eccentricity of applied loads. For veneer and other exposed masonry applications, tighter tolerances for aesthetic considerations may be included in the project specifications.

Cleaning. If acid or other caustic cleaning materials are permitted, the optional checklist requires that the project specification cover methods of neutralization following cleaning.

There are many items not mentioned in the MSJC Specification that still must be covered in the project spec. Among these are delivery, storage, handling, and protection of materials; placement requirements for flashing and weep holes; and protection of walls during construction. Coordinate your office master specs with the requirements of the MSJC to make sure that all Specification material and workmanship requirements are covered.

18.4 FIELD OBSERVATION AND INSPECTION

Field observation and inspection have become increasingly important with the explosion of construction litigation. The intent of these site visits is to ensure that the finished work complies with the contract documents, and that the workmanship meets the required standards.

Good workmanship affects masonry performance, and is essential to high-quality construction. Masonry construction requires skilled craftsmen working cooperatively with the architect and engineer to execute the design. The goal of quality workmanship is common to all concerned parties for various reasons of aesthetics, performance, and liability.

Responsibility for construction in design-bid-build projects rests with the contractor. The A/E is not a party to the construction contract, but acts solely as the owner's representative in the field. As part of the team, the architect can assist the contractor and offer expertise in solving or avoiding potential problems. The architect must also act as interpreter of design intent, and safeguard the project quality by assuring proper execution of the work according to the requirements of the contract documents.

Independent inspection agencies or testing laboratories serve a different function. If required by the specifications, it is their responsibility to test various materials and assemblies to verify compliance with reference standards, design strengths, and performance criteria. Field observation and inspection procedures are necessary to assure the successful translation of the design, drawings, and specifications into a completed structure that functions as intended. An independent inspector's authority does not extend to supervision of the work, or to revision of details or methods without the written approval of the architect, owner, and contractor.

The following is intended as a comprehensive guide to field observation of masonry construction. It is not intended for structural inspection of load-bearing masonry. For a discussion of structural inspection requirements, refer to Chapters 12 and 17.

18.4.1 Materials

An inspector must be familiar with the project specifications and must verify compliance of materials at the job site with the written requirements. Manufacturers must supply test certificates showing that the material properties meet or exceed the referenced standards as to ingredients, strength, dimensional tolerances, durability, and so on.

Unit masonry may be visually inspected for color, texture, and size and compared to approved samples. Units delivered to the job site should be inspected for physical damage, and storage/protection provisions checked. Stone, brick, or concrete masonry that has become soiled, cracked, chipped, or broken in transit should be rejected. If the manufacturer does not supply test certificates, random samples should be selected and sent to the testing agency for laboratory verification of minimum standards. The inspector should also check the moisture condition of clay masonry at the time of laying since initial rates of absorption affect the bond between unit and mortar, and the strength of the mortar itself. Visual inspection of a broken unit can indicate whether field tests of absorption rates should be performed (refer to Chapter 15).

Mortar and grout ingredients should be checked on delivery for damage or contamination, and to assure compliance with the specified requirements. Packaged materials should be sealed with the manufacturer's identifying labels legible and intact. Cementitious ingredients that show signs of water absorption should be rejected. If material test certificates are required, check compliance with the specifications.

Acceptable mixing and batching procedures should be established at the preconstruction conference to assure quality and consistency throughout the job. If field testing of mortar prisms is required, preconstruction laboratory samples should be prepared and tested sufficiently in advance of construction to serve as a benchmark. Retempering time should be monitored to preclude the use of mortar or grout that has begun to set.

Accessories must also be checked for design compliance. The inspector must assure use of proper anchoring devices, ties, inserts, flasing, weep and drainage accessories, and reinforcement. Steel shelf angles and lintels should carry certification of yield strength and be properly bundled and identified for location within the structure.

18.4.2 Construction

Foundations, beams, floors, and other structural elements that will support the masonry should be checked for completion to proper line and grade before the work begins. Adequate structural support must be assured, and areas cleaned of dirt, grease, oil, laitance, or other materials that might impair bond of the mortar or grout. Overall dimensions and layout must be verified against the drawings and field adjustments made to correct discrepancies. Steel reinforcing dowels must be checked for proper location in relation to cores, joints, or cavities. The inspector should also keep a log of weather conditions affecting the progress or performance of the work. Inspectors should

not interfere with the workers or attempt to direct their activities. If methods or procedures are observed that appear to conflict with the specifications or which might jeopardize the quality or performance of the work, they should be called to the attention of the contractor or foreman, and adjustments made as necessary.

18.4.3 Workmanship

Perhaps the single most important element in obtaining strong, water-resistant masonry walls is full mortar joints and proper joint tooling. Partially filled head joints or furrowed mortar beds will produce voids that offer only minimal resistance to moisture infiltration. Poorly tooled joints allow excessive water infiltration (refer to Chapter 9). The first course of masonry must be carefully aligned vertically and horizontally, and fully bedded to assure that the remainder of the wall above will be plumb and level. Even if hollow CMU construction requires only face-shell bedding, this critical base course must have full mortar under face shells and webs. Head joints must be buttered with mortar and shoved tight against the adjacent unit to minimize water infiltration. Units must not be moved, tapped, or realigned after initial placement, or the mortar bond will be destroyed. If a unit is displaced, all head and bed mortar must be removed and replaced with fresh material. Spot checks for proper bond can be made by lifting a fresh unit out of place to see if both faces are fully covered with adhered mortar.

The inspector should check for proper embedment and coverage of anchors, ties, and joint reinforcement, and should monitor vertical coursing and joint uniformity. Differential widths or thicknesses of mortar joints can misalign the modular coursing and interfere with proper location of openings, lintels, and embedded items. Storypoles, string lines, and tapes or templates should be used to check coursing between corner leads. Nail and line pinholes must be filled with mortar when string lines are removed to avoid water penetration through these voids. Work of other trades that penetrates the masonry should be incorporated during construction of the wall and not cut in later. Drainage cavities must be kept free of mortar fins and droppings to avoid plugging weep holes, damaging flashing, or interfering with grout pours. When they become thumbprint hard, joints should be tooled to compress the mortar surface.

The mason should place all vertical and horizontal reinforcement as the work progresses, holding the bars in correct alignment with spacers or wire. Minimum clearances should be maintained, and bar splices lapped and securely tied. The inspector should check to see that reinforcement is free of rust, loose scale, or other materials that could impair bond to the mortar. Care should be taken to avoid moving or jarring vertical steel that is already embedded in lower grouted courses.

Inspection should also include proper installation of flashing, control joints, expansion joints, lintels, sills, caps, copings, and frames. Door frames must be adequately braced until the mortar has set and the masonry work surrounding them is self-supporting.

Grouting is important to the structural integrity of reinforced masonry walls. Cavities and cores should be inspected before the grout is placed, and any remaining dirt, debris, mortar droppings, or protrusions removed before the work proceeds. Cleanout plugs left for high-lift pours allow visual inspection from below by use of a mirror inserted through the opening. Cleanout units should be fully mortared and shoved into place after inspection, then

braced against blowout from the fluid pressure of the grout against the uncured mortar. The consistency of the grout should allow for easy pouring or pumping, and complete filling of the space. Vibrating or consolidation to remove air bubbles and pockets also ensures that the grout covers fully around and between ties and reinforcement. Grout consolidation should occur 5 to 10 minutes after placement, and reconsolidation after initial water loss and settlement. Reconsolidation should occur within 30 minutes of initial consolidation. A low-velocity electric vibrator placed into each grouted core or at 12- to 16-in. intervals in a grouted cavity for a few seconds is considered sufficient. Timing of grout pours should be monitored to avoid excessive lateral pressure on uncured joints.

18.4.4 Protection and Cleaning

Throughout the construction period, both the masonry materials and the work must be protected from the weather. Materials must be stored off the ground to prevent contamination or staining. Exposed tops of unfinished walls must be covered each night to keep moisture out of the cores and cavities by draping waterproof plastic or canvas 2 ft down each side. Cold weather may require heating of materials and possibly the application of heat during the curing period. Hot, dry climates cause rapid evaporation, and mortar mixes may have to be adjusted to compensate for premature drying. Both hot and cold weather may necessitate moist curing. The inspector must assure that the required precautions are taken to avoid harmful effects, and must also see that completed work is protected from damage during other construction operations.

Suitable cleaning methods must be selected on the basis of the type of stain involved and the type of material to be cleaned. Improper use of cleaning agents can create more problems than are solved by their application. Mortar smears on the face of the masonry should be removed daily before they are fully hardened, and dry-brushed when powdery to prevent stains. Paints, textured coatings, or clear water repellents, if specified, should be applied carefully over clean, dry walls, and adjacent work protected against splatters and drips.

It is the inspector's job to see that the instructions and requirements of the drawings and specifications are carried out in the field. Safeguarding the quality of the work without impeding its progress is best achieved through cooperation with the contractor and workers. Good design and good intentions are not sufficient in themselves to assure quality of the finished product. The inspector can facilitate the proper execution of the work, ensuring masonry structures that are as durable and lasting as the materials of which they are made.

18.4.5 Moisture Drainage

Early in the construction, the drainage system should be checked to assure the unobstructed flow of water to the weeps and rapid drainage of moisture from the wall. A quick field check involves briefly placing a water hose in the cavity after the mortar has had a chance to set (see Fig. 18-3). Water should drain immediately and freely from the weep just below the test location (see Fig. 18-4). As water travels laterally along the flashing, it should begin to drain from adjacent weeps as well. The test should be brief to avoid saturating the cavity, but is a quick and effective means of detecting blocked weeps.



Figure 18-3 Garden hose placed briefly in wall cavity to test for obstruction of water flow to weeps.



Figure 18-4 Water should drain immediately and freely from the weep hole immediately below the test location.

This page intentionally left blank.

Appendix

A

GLOSSARY

A

Absorption The amount of water that a masonry unit absorbs when immersed in water under specified conditions for a specified length of time.

Absorption Rate The weight of water absorbed when a brick is partially immersed for 1 minute, usually expressed in either grams or ounces per minute. Also called suction or **initial rate of absorption**.*

Abutment (1) That part of a pier or wall from which an arch springs, specifically the support at either end of an arch, beam, or bridge. (2) A skewback and the masonry that supports it.

Accelerator Ingredient added to mortar or grout to speed hydration of cementitious components to hasten set time.

ACI American Concrete Institute.

Adhered Attached by adhesion rather than mechanical anchorage, as in adhered veneer.

*Boldface type within entries denotes terms for which there are glossary entries.

Adhesion-Type Ceramic Veneer Thin sections of ceramic veneer, held in place by adhesion of mortar to unit and to backing. No metal anchors are required.

Admixture A material other than water, aggregates, hydraulic cement, or fiber reinforcement used as an ingredient of grout or mortar and added to the batch immediately before or during its mixing.

Adobe Soil of diatomaceous content mixed with sufficient water so that plasticity can be developed for molding into masonry units.

Aggregate Granular mineral material such as natural sand, manufactured sand, gravel, crushed stone, or air-cooled blast furnace slag.

Air Drying The process of drying block or brick without any special equipment, simply by exposure to ambient air.

Air Entraining The capability of a material or process to develop a system of minute bubbles of air in cement paste, mortar, or grout during mixing.

AISC American Institute of Steel Construction.

Alumina The oxide of aluminum; an important constituent of the clays used in brick, tile, and refractories.

Anchor See **Connector, Anchor**.

Anchored-Type Ceramic Veneer Thick sections of ceramic veneer held in place by grout and wire anchors connected to backing wall.

Angle Closer A special-shaped brick used to close the bond at the corner of a wall.

ANSI American National Standards Institute (formerly USAS).

Arch A vertically curved compressive structural member spanning openings or recesses; may also be built flat by using special masonry shapes or placed units.

Abutment The skewback of an arch and the masonry that supports it.

Arch Axis The median line of the arch ring.

Back Arch A concealed arch carrying the back of a wall where the exterior facing is carried by a lintel.

Camber The relatively small rise of a jack arch.

Constant-Cross-Section Arch An arch whose depth and thickness remain constant throughout the span.

Crown The apex of the arch ring. In symmetrical arches, the crown is at midspan.

Depth The depth (d) of any arch is the dimension that is perpendicular to the tangent of the axis. The depth of a jack arch is taken to be its greatest vertical dimension.

Extradados The exterior curve that bounds the upper extremities of the arch.

Fixed Arch An arch whose skewback is fixed in position and inclination. Plain masonry arches are, by the nature of their construction, fixed arches.

Gothic or Pointed Arch An arch with relatively high rise, whose sides consist of arcs or circles, the centers of which are at the level of the spring line. The Gothic arch is often referred to as a drop, equilateral, or laced arch, depending on whether the spacings of the center are respectively less than, equal to, or more than the clear span.

Intrados The interior curve that bounds the lower extremities of the arch (see **Soffit**). The distinction between soffit and intrados is that the intrados is linear, whereas the soffit is a surface.

Jack Arch An arch having horizontal or nearly horizontal upper and lower surfaces. Also called flat or straight arch.

Major Arch Arch with span greater than 6 ft and having equivalent uniform loads greater than 1000 lb/ft. Typically, a Tudor arch, semicircular arch, Gothic arch, or parabolic arch. Rise-to-span ratio greater than 0.15.

Minor Arch Arch with maximum span of 6 ft and loads not exceeding 1000 lb/ft. Typically, a jack arch, segmental arch, or multi-centered arch. Rise-to-span ratio less than or equal to 0.15.

Multi-Centered Arch An arch whose curve consists of several arcs of circles which are normally tangent at their intersections.

Relieving Arch One built over a lintel, flat arch, or smaller arch to divert loads, thus relieving the lower member from excessive loading. Also known as discharging or safety arch.

Rise The rise (r) of a minor arch is the maximum height of arch soffit above the level of its spring line. The rise (f) of a major parabolic arch is the maximum height of arch axis above its spring line.

Roman arch A semicircular arch. If built of stone, all units are wedge shaped.

Segmental Arch An arch whose curve is circular but less than a semicircle.

Semicircular Arch An arch whose curve is a semicircle.

Skewback The inclined surface on which the arch joins the supporting wall. For jack arches the skewback is indicated by a horizontal dimension (K).

Soffit The undersurface of the arch.

Span The horizontal distance between abutments. For minor arch calculations the clear span (S) of the opening is used. For a major parabolic arch the span (L) is the distance between the ends of the arch axis at the skewback.

Spring Line For minor arches, the line where the skewback cuts the soffit. For major parabolic arches, the term commonly refers to the intersection of the arch axis with the skewback.

Trimmer Arch An arch (usually a low-rise arch of brick) used for supporting a fireplace hearth.

Tudor Arch A pointed four-centered arch of medium rise-to-span ratio.

Voussoir One of the wedge-shaped masonry units which forms an arch ring.

Arch Stone Voussoir stone.

Arching Action The distribution of loads in masonry over an opening. The load is usually assumed to occur in a triangular pattern above the opening extending from a maximum at the center of the span to zero at the supports.

Architectural Terra Cotta Hard-burned, glazed or unglazed clay building units, plain or ornamental, machine extruded or hand molded, and generally larger in size than brick or facing tile. See **Ceramic Veneer**.

Arris A sharp edge of brick, stone, or other building element.

ASCE American Society of Civil Engineers.

ASHRAE American Society for Heating, Refrigeration, and Air Conditioning Engineers.

ASTM American Society for Testing and Materials.

Autoclave A type of curing system in the production of concrete masonry units which utilizes superheated steam under pressure to promote strength of units.

Autoclaved Aerated Concrete (AAC) A cementitious product based on calcium silicate hydrates in which low density is attained by the inclusion of an agent resulting in macroscopic voids and which is subjected to high-pressure steam curing.

Axhammer An axe for spalling or dressing rough stone; has either one cutting edge and one hammer face, or two cutting edges. Also called **mason's hammer**.

B

Back Filling (1) Rough masonry built behind a facing or between two faces. (2) Filling over the extrados of an arch. (3) Brickwork in spaces between structural timbers, sometimes called brick nogging.

Backing Surface or assembly to which veneer is attached.

Backup That part of a masonry wall behind the exterior facing.

Band Course A continuous, horizontal band of masonry marking a division in the wall elevation. Sometimes called **belt course**, **string course**, or sill course.

Basalt Dark, fine-grained igneous rock used extensively as a paving stone and occasionally as a building stone.

Basketweave A checkerboard pattern of bricks or pavers, flat or on edge. Bricks or modular groups of bricks laid at right angles to those adjacent.

Bat A broken brick or piece of brick with one undamaged end. Also called a brickbat. Usually about one-half brick.

Batter Masonry that is recessed or sloping back in successive courses; the opposite of a corbel; to rack back.

Bearing Plate A plate placed under a truss, beam, or girder to distribute the load.

Bed (1) In masonry and bricklaying, the side of a masonry unit on which it lies in the course of the wall; the underside when placed horizontally. (2) The layer of mortar on which the masonry unit is set.

Bed Joint See **Joint, Bed**.

Bedding Course The first layer of mortar at the bottom of a masonry wall.

Belt Course A narrow horizontal course of masonry, sometimes slightly projected, such as window sills which are made continuous. Sometimes called **string course** or sill course.

BIA Brick Industry Association (formerly known as Brick Institute of America and **SCPI**).

Blind Header A concealed header in the interior of a wall, not showing on the faces of the wall.

Block, Concrete See **Concrete Masonry Unit**.

Blocking A method of bonding two adjoining or intersecting walls, not built at the same time, by means of offsets whose vertical dimensions are not less than 8 in.

Blockwork Masonry of concrete block and mortar.

Bolster A blocking chisel for masonry work. A broad-edged chisel made in a number of sizes, shapes, and weights.

Bond

Adhesion Bond Adhesion between masonry units and mortar or grout.

Masonry Bond Connection of masonry wythes with overlapping header units.

Metal Tie Bond Connection of masonry wythes with metal ties or joint reinforcement.

Mortar Bond or Grout Bond Adhesion between mortar or grout and masonry units, reinforcement, or connectors.

Pattern Bond Patterns formed by the exposed faces of the masonry units, for example, running bond or Flemish bond.

American Bond Bond pattern in which every sixth course is a header course and the intervening courses are stretcher courses.

Basketweave Bond Modular groups of units laid at right angles to those adjacent to form a pattern.

Blind Bond Bond pattern to tie the front course to the wall where it is not desirable that any headers should be seen in the face work.

Common Bond Bond pattern in which five to seven stretcher courses are laid between headers.

Cross Bond Bond pattern in which the joints of the stretcher in the second course come in the middle of the stretcher in the first course composed of headers and stretchers intervening.

Dutch Cross Bond A bond having the courses made up alternately of headers and stretchers. Same as an **English cross bond**.

English Bond Bond pattern with alternating courses of headers and stretchers. The headers and stretchers are situated plumb over each other. The headers are divided evenly over the vertical joints between the stretchers.

English Cross Bond A variation of English bond, but with the stretchers in alternate courses centered on the stretchers above and below. Also called **Dutch cross bond**.

Flemish Bond Bond pattern in which each course consists of alternate stretchers and headers, with the headers in alternate courses centered over the stretchers in intervening courses.

Flemish Garden Bond Bond pattern in which units are laid so that each course has a header to every three to five stretchers.

Header Bond Bond pattern showing only headers on the face, each header divided evenly on the header under it.

Herringbone Bond Arrangement of units in a course in a zigzag fashion, with the end of one unit laid at right angles against the side of a second unit.

Random Bond Masonry constructed without a regular pattern.

Running Bond Placement of masonry units such that head joints in successive courses are horizontally offset at least one-quarter of the unit length.

Stack Bond (1) Placement of units such that the head joints in successive courses are vertically aligned. (2) Units laid so that no overlap occurs; head joints form a continuous vertical line. Also called **plumb joint bond, straight stack, jack bond, jack on jack,** and **checkerboard bond**.

Reinforcing Bond Adhesion between steel reinforcement and mortar or grout.

Bond Beam A course or courses of a masonry wall grouted and usually reinforced in the horizontal direction serving as an integral beam in the

wall. May serve as a horizontal tie, as a bearing course for structural members, or as a flexural member itself.

Bond Beam Unit A hollow masonry unit with depressed sections forming a continuous channel in which reinforcing steel can be placed for embedment in grout.

Bond Breaker A material used to prevent adhesion between two surfaces.

Bond Course The course consisting of units that overlap more than one wythe of masonry.

Bond Strength The resistance of mortar or grout to separation from masonry units or reinforcement with which it is in contact.

Bonder A bonding unit. Also called a **header**.

Brick A manufactured masonry unit made from fired clay or shale, concrete, or sand-lime materials, which is usually formed in the shape of a rectangular prism, and typically placed with one hand.

Acid-Resistant Brick Brick suitable for use in contact with chemicals, usually in conjunction with acid-resistant mortars.

Adobe Brick An unfired, air-dried, roughly molded brick of earth or clay. When made with an emulsifier or fibers, called "stabilized adobe."

Angle Brick Any masonry unit shaped to an oblique angle to fit a salient corner.

Arch Brick Wedge-shaped masonry unit (usually a manufactured clay unit) for special use in an arch. Arch bricks provide uniformity of mortar joint thicknesses as the arch is turned. Also refers to the hard burned brick units found in the arch section of a scove kiln.

Building Brick Brick for building purposes not especially produced for texture or color (formerly called common brick).

Bullnose Brick A brick having one or more rounded corners.

Calcium Silicate Brick Brick made from sand and lime, with or without the inclusion of other materials.

Clay Brick A solid or hollow masonry unit of clay or shale, usually formed into a rectangular prism while plastic and burned or fired in a kiln.

Clinker Brick A very hard-burned brick whose shape is distorted due to nearly complete vitrification.

Common Brick See **Building Brick**.

Concrete Brick Brick made from portland cement, water, and suitable aggregates, with or without the inclusion of other materials.

Cored Brick A brick in which the holes consist of less than 25% of the section.

Dry Press Brick Brick formed in molds under high pressures from relatively dry clay (5 to 7% moisture content).

Economy Brick A brick whose nominal dimensions are 4 in. \times 4 in. \times 8 in.

Facing Brick Brick made especially for facing purposes.

Fire Brick (1) Any type of refractory brick, specifically fire-clay brick.
(2) Brick made of refractory ceramic material that will resist high temperatures.

Firebox Brick Brick manufactured from clay, fire clay, shale, or similar naturally occurring earthy substances and subjected to heat treatment at elevated temperatures.

Floor Brick Smooth, dense brick, highly resistant to abrasion, used as finished floor surface.

Gauged Brick (1) Brick that has been ground or otherwise produced according to accurate dimensions. (2) A tapered arch brick.

Glazed Brick A brick prepared by fusing on the surface a ceramic glazing material; brick having a glassy surface.

Hollow Brick Brick whose net cross-sectional area (solid area) in any plane parallel to the surface containing the cores, cells, or deep frogs is less than 75% of its gross cross-sectional area measured in the same plane.

Jumbo Brick A generic term indicating a brick larger in size than the standard. Some producers use this term to describe oversize brick of specific dimensions manufactured by them.

Norman Brick A brick whose nominal dimensions are 4 in. \times 2 $\frac{2}{3}$ in. \times 12 in.

Paving Brick, Heavy Vehicular Brick intended for use in areas with a high volume of heavy vehicular traffic.

Paving Brick, Light Traffic Brick intended for use as paving material to support pedestrian and light vehicular traffic.

Roman Brick A brick whose nominal dimensions are 4 in. \times 2 in. \times 12 in.

Salmon Brick Generic term for underburned brick that is more porous and lighter colored than hard-burned brick. Usually pinkish-orange in color.

Sand-Lime Brick See **Calcium Silicate Brick**.

Sand-Struck Brick See **Soft-Mud Brick**.

SCR Brick Brick whose nominal dimensions are 6 in. \times 2 $\frac{2}{3}$ in. \times 12 in.

Sewer Brick Low-absorption, abrasion-resistant brick intended for use in drainage structures.

Soft-Mud Brick Brick produced by molding (often by a hand process) relatively wet clay (20 to 30% moisture).

Stiff-Mud Brick Brick produced by extruding a stiff but plastic clay (12 to 15% moisture) through a die.

Wire-Cut Brick Brick formed by forcing plastic clay through a rectangular opening designed to shape the clay into bars. Before burning, wires pressed through the plastic mass cut the bars into brick units.

Brick Ax See **Brick Hammer**.

Brick Facing See **Brick Veneer**.

Brick Grade Designation denoting durability of clay brick, expressed as SW (severe weathering), MW (moderate weathering), and NW (negligible weathering).

Brick Hammer A steel tool, one end of which has a flat, square surface used as a hammer, for breaking bricks, driving nails, and so on. The other end forms a chisel peen used for dressing bricks. (Also called brick ax or bricklayer's hammer.)

Brick Ledge A ledge on a footing or wall which supports a course of masonry.

Brick Trowel A trowel having a flat, triangular steel blade in an offset handle used to pick up and spread mortar. The narrow end of the blade is called the "point"; the wide end, the "heel."

Brick Type Designation for clay brick that indicates qualities of appearance including tolerance, chippage, and distortion. Expressed as face brick standard (FBS), face brick extra (FBX), and face brick architectural (FBA) for solid brick; and hollow brick standard (HBS), hollow brick extra (HBX), hollow brick architectural (HBA), and hollow building brick (HBB) for hollow brick.

Brickbat See **Bat**.

Building Ecology The study of the dynamic interaction of a building with its external environment and its occupants, equipment, and processes.

Bullnose Unit A brick or concrete masonry unit having one or more rounded exterior corners.

Buttering Placing mortar on a masonry unit with a trowel.

Buttress A projecting structure built against a wall or building to give it greater strength and stability.

C

Carbonation A process of chemical weathering whereby minerals that contain sodium oxide, calcium oxide, potassium oxide, or other basic oxides are changed to carbonates by the action of carbonic acid derived from atmospheric carbon dioxide and water.

Cast Stone See **Stone, Cast**.

Cavity An unfilled space.

C/B Ratio The ratio of the weight of water absorbed by a masonry unit during immersion in cold water for 24 hours to the weight absorbed during

immersion in boiling water for 5 hours. An indication of the probable resistance of brick to freezing and thawing. Also called **saturation coefficient**. (See ASTM C67.)

Cell See **Core**.

Cellular Concrete See **Autoclaved Aerated Concrete (AAC)**.

Cement A general term for an adhesive or binding material. See specific terms such as **Portland Cement** or **Masonry Cement**.

Cement Mortar A mixture of cement, sand, or other aggregates and water used for plastering over masonry or to lay masonry units.

Cementitious Material When proportioning masonry mortars, the following are considered cementitious materials: portland cement, blended hydraulic cement, masonry cement, quicklime, and hydrated lime.

Cementitious Material, Hydraulic An inorganic material or a mixture of inorganic materials, which sets and develops strength by chemical reaction with water by formation of hydrates and is capable of doing so under water.

Cement-Lime Mortar A mixture of cement, lime, sand, or other aggregates and water used for plastering over masonry or to lay masonry units.

Centering Temporary formwork for the support of masonry arches, hearth extensions, or lintels during construction. Also called center(s).

Ceramic Broad term for products made from heat-resistant, non-metallic, inorganic materials such as clay, bauxite, alumina, silicon carbide, etc., which have been fired to incipient fusion.

Ceramic Veneer A type of architectural terra cotta, characterized by large face dimensions and thin sections ranging from $1\frac{1}{8}$ to $2\frac{1}{4}$ in. in thickness.

Chimney Lining Fire clay or terra cotta material or refractory cement made to be built inside a chimney throat. That part of a chimney directly above the fireplace where the walls are brought close together.

Cinder An aggregate, sometimes used in the manufacture of concrete Masonry Units, made from the combustion of coal or volcanic lava.

Cinder Block See **Concrete**.

Clay An earthy or stony mineral aggregate consisting of hydrous silicates of alumina, plastic when sufficiently pulverized and wetted, rigid when dry, and vitreous when fired to a sufficiently high temperature.

Clay Mortar Finely ground clay used as a plasticizer for masonry mortars.

Cleanout An opening at the bottom of a grout space of sufficient size and spacing to allow the removal of debris.

Closer (1) The last masonry unit laid in a course. It may be whole or a portion of a unit. (2) A stone course running from one window sill to another (a variety of string course).

Closure Supplementary or short-length units used at corners or jambs to maintain bond patterns.

CMU Concrete masonry unit.

Cold Weather Construction Procedures used in constructing masonry when ambient air temperature or the temperature of the masonry units is below 40°F.

Collar Joint see **Joint, Collar**.

Color Pigment Inorganic matter used in concrete and mortar to vary the color.

Combustible Capable of undergoing combustion.

Composite Action Transfer of stress between components of a member designed so that in resisting loads, the combined components act together as a single member.

Concrete Block See **Concrete Masonry Unit**.

Concrete Brick See **Brick, Concrete**.

Concrete Masonry Unit Manufactured masonry unit made from portland cement, mineral aggregates, and water, with or without the inclusion of other materials.

Concrete Block Hollow concrete masonry unit made from portland cement and suitable aggregates such as sand, crushed stone, cinders, burned clay or shale, pumice, scoria, or air-cooled or expanded blast furnace slag, with or without the inclusion of other materials.

"A" Block Cored masonry unit with one end closed by a cross web and the opposite end open or lacking an end cross web, typically forming two cells when laid in running bond. Also called open end block.

Cap Block Solid flat slab, usually $2\frac{1}{4}$ in. thick, used as a capping unit for parapet and garden walls. Also used for stepping stones, patios, veneering, etc.

Channel Block Hollow unit with web portions depressed less than $1\frac{1}{4}$ in. to form a continuous channel for reinforcing steel and grout.

Concrete Block Hollow or solid unit consisting of portland cement and suitable aggregates combined with water. Other materials such as lime, fly ash, air-entraining agent, or other admixtures may be permitted.

Ground Faced Block Concrete masonry unit in which the exposed surface is ground to a smooth finish.

Jamb Block Block specially formed for the jamb of windows or doors, generally with a vertical slot to receive window frames, etc.

Offset Block Concrete masonry unit that is not rectangular. Usually used as a corner block to maintain the masonry pattern on the exposed face of a single-wythe wall whose thickness is less than half the length of the unit.

Return Corner Block Concrete masonry unit that has one flat end for corner construction.

Screen Block Open-faced masonry units used for decorative purposes or to partially screen areas from the sun or outside viewers.

Sculptured Block Block with decorative formed or molded surfaces.

Shadow Block Block with a face formed in planes to develop surface shadow patterns.

Sill Block Solid concrete masonry unit used for the sills of a wall.

Slump Block Concrete masonry unit produced so it will slump or sag in irregular fashion before it hardens.

Split-Faced Block Concrete masonry unit with one or more faces purposely fractured to expose the rough aggregate texture, to provide architectural effects in masonry wall construction.

Concrete Masonry Unit, Architectural Architectural concrete masonry unit having textured or sculptured surfaces. Methods used to obtain different surface textures include splitting, grinding, forming vertical striations, and causing the units to “slump.” Sculptured faces are obtained by forming projecting ribs or flutes, either rounded or angular, as well as vertical and horizontal scoring, recesses, and curved faces.

Concrete Masonry Unit, Lightweight Concrete masonry unit whose oven-dry density is less than 105 lb/cu ft.

Concrete Masonry Unit, Medium Weight Concrete masonry unit whose oven-dry density is at least 105 lb/cu ft and less than 125 lb/cu ft.

Concrete Masonry Unit, Moisture-Controlled Concrete masonry unit whose moisture content conforms to the requirements for Type I classification of ASTM Specification C55, C90, or C129.

Concrete Masonry Unit, Normal Weight Concrete masonry unit whose oven-dry density is at least 125 lb/cu ft or more.

Concrete Masonry Unit, Prefaced Concrete or calcium silicate masonry unit with the exposed-to-view-in-place surfaces covered at the point of manufacture with resin, resin and inert filler, or cement and inert filler, to produce a smooth resinous tile facing.

Connector Mechanical device, including anchors, wall ties, and fasteners, for securing two or more pieces, parts, or members together.

Connector, Anchor Metal rod, wire, or strap that secures masonry to its structural support.

Connector, Fastener Device used to attach non-masonry materials to masonry.

Connector, Wall Tie Metal connector which connects wythes of masonry walls together.

Control Joint See **Joint, Control**.

Coping Masonry units laid on top of a finished wall. (1) A covering on top of a wall exposed to the weather, usually sloped to carry off water. (2) The materials or masonry units used to form a cap or a finish on top of a wall, pier, chimney, or pilaster to protect the masonry below from water penetration. Commonly extended beyond the wall face and cut with a drip.

- Coping Unit** Solid masonry unit for use as the top and finished course in wall construction.
- Corbel** (1) The projection of successive courses of masonry out from the face of the wall to increase the wall thickness or to form a shelf or ledge. (2) A shelf or ledge formed by successive courses of masonry projecting out from the face of a wall, pier, or column.
- Corbeled Vault** Masonry roof constructed from opposite walls or from a circular base, by shifting courses slightly and regularly inward until they meet. The resulting stepped surface may be smoothed or curved, but no true arch action is involved.
- Core** (1) Molded open space in a concrete masonry unit. (2) Hollow space within a concrete masonry unit formed by the face shells and webs. (3) The holes in clay units. Also called **cell**.
- Corner Pole** See **Story Pole**.
- Cornerstone** (1) Generally, a stone that forms a corner or angle in a structure. (2) More specifically, a stone situated prominently, near the base of a corner of a building, carrying information recording the dedicatory dates and other pertinent information. In some buildings, these stones contain or cap a vault in which contemporary memorabilia are preserved.
- Corrosion** Chemical or electrochemical reaction between a material, usually a metal, and its environment that produces a deterioration of the material and its properties.
- Corrosion Resistant** Material that is inherently resistant to, or treated or coated to retard, harmful oxidation or other corrosive action.
- Course** Horizontal layer of units in masonry other than paving.
- Crack** Flaw consisting of complete or incomplete separation within a single element or between contiguous elements of constructions.
- Crack Control** Methods used to control the extent, size, and location of cracking in masonry, including reinforcing, movement joints, and dimensional stability of masonry materials.
- Cramp Anchor** U-shaped metal connector used to hold adjacent units of masonry together, as in a parapet or wall coping, or to secure stone slab veneers together.
- Crazing** (1) The cracking that occurs in fired glazes or other ceramic coatings due to tensile stresses. (2) A network of apparent fine cracks at or beneath the surface of materials such as in transparent plastics, glazed ceramics, glass, or coatings.
- Creep** Time-dependent deformation due to sustained load.
- Cross-Sectional Area, Gross** (1) Area delineated by the out-to-out dimensions of masonry in the plane under consideration. (2) Total cross-sectional area of a specified section.
- Cross-Sectional Area, Net** (1) Area of masonry units, grout, and mortar crossed by the plane under consideration based on out-to-out dimensions. (2) Gross cross-sectional area minus the area of ungrouted cores, notches,

cells, and unbedded areas. Net area is the actual surface area of a cross section of masonry.

Curing Maintenance of proper conditions of moisture and temperature during initial set to develop required strength and reduce shrinkage in concrete products and mortar.

Curtain Wall See **Wall, Curtain**.

D

Dampcheck Impervious horizontal layer to prevent vertical penetration of water in a wall, consisting of either a course of solid masonry or metal or a thin layer of asphaltic or bituminous material. Generally near grade to prevent upward migration of moisture by capillary action. Also called **damp course**.

Damping Reduction of amplitude of vibrations due to energy loss (as in damping of vibrations from seismic shock).

Dampproofing Preparation of a wall to prevent moisture from penetrating through it.

Density Ratio of the mass of an object to its volume.

Density (of Masonry Units) Oven-dry weight per unit volume.

Diaphragm Roof or floor system designed to transmit lateral forces to shear walls or other vertical resisting elements.

Differential Movement Movement of two elements relative to one another that differs in rate or direction.

Dimension Stone See **Stone, Dimension**.

Dimensions of Masonry Units

Actual Measured dimensions of a masonry unit.

Height (1) Vertical dimension of the unit in the face of a wall. (2) Vertical dimension of masonry units or masonry, measured parallel to the intended face of the unit or units.

Length (1) Horizontal dimension of the unit in the face of the wall. (2) Horizontal dimension of masonry units or masonry, measured parallel to the intended face of the unit or units.

Nominal (1) Dimension greater than the specified (standard) dimension by the thickness of one joint, but not more than 13 mm or $\frac{1}{2}$ in. (2) A dimension that may be greater than the specified masonry dimension by the thickness of a mortar joint.

Specified (1) Nominal dimension less the thickness of a standard mortar joint, that is, net dimension of the masonry unit. (2) Dimensions to which masonry units or constructions are required to conform. (3) Standard dimensions of a masonry unit, plus or minus any allowable size tolerances.

Thickness (1) Dimension designed to lie at right angles to the face of the wall, floor, or other assembly. (2) *Thickness (width)* Horizontal dimension of masonry units or masonry measured perpendicular to the intended face of the masonry unit or units.

Dog's Tooth A brick laid with its corners projecting from the wall face.

Dolomite Sedimentary carbonate rock (a variety of limestone) that consists largely or entirely of the mineral dolomite.

Dolomitic Lime Trade term for high-magnesium lime. Also a misnomer, as the product does not contain dolomite.

Dolomitic Limestone See **Limestone**.

Dovetail Anchor Splayed tenon shaped like a dove's tail, that is, broader at its base, that fits into the recess of a corresponding mortise.

Dowel Straight metal bar used to connect two sections of masonry.

Drip Groove or slot cut beneath and slightly behind the forward edge of a projecting stone member, such as a sill, lintel, or coping, to cause rainwater to drip off and prevent it from penetrating a wall.

Dry-Stack Masonry Masonry work laid without mortar.

Durability Ability of a material to resist weathering action, chemical attack, abrasion, and other conditions of service.

Durability (Freeze-Thaw) Ability of masonry units to maintain integrity under the forces caused by the cyclic action of freezing and thawing in the presence of moisture.

E

Eccentricity (1) Distance between a vertical load reaction and a centroidal axis of masonry. (2) Normal distance between the centroidal axis of a member and the parallel resultant load.

Effective Height (1) Clear height of a braced member between lateral supports, used for calculating the slenderness ratio of a member. (2) Height of a member that is assumed when calculating the slenderness ratio.

Effective Thickness Thickness of a member that is assumed when calculating the slenderness ratio.

Effective Width That part of the width of a member taken into account when designing T or L beams.

Efflorescence, Water-Insoluble Crystalline deposit, usually white, of water-soluble compounds which, on reaching the masonry surface, become water-insoluble, primarily through carbonation (also sometimes called lime run or calcium carbonate stain). Normally requires acid washing for removal.

Efflorescence, Water-Soluble Crystalline deposit, usually white, of water-soluble compounds on the surface of masonry. Normally can be removed with water washing.

Embodied Energy Amount of energy required to produce a given quantity of material, from raw materials acquisition through processing, manufacture, and distribution.

Empirical Design Design based on application of physical limitations learned from experience or observations gained through experience, without structural analysis.

End-Construction Tile Structural clay tile units designed to be laid with the axis of the cells vertical.

Engineered Masonry Masonry which has been analyzed for vertical and lateral load resistance and members proportioned to resist design loads in accordance with working stress design or strength design principles.

Equivalent Thickness (1) Solid thickness to which a hollow unit would be reduced if the material in the unit were recast with the same face dimensions but without voids. (2) Percent solid volume times actual width divided by 100. (3) $E_T = \text{net volume} \div (\text{specified unit length} \times \text{specified unit height})$. (4) Average thickness of solid material in a unit.

Exfoliation Peeling or scaling of stone or clay brick surfaces caused by chemical or physical weathering.

Expansion Joint See **Joint, Expansion**.

Extrados Exterior curve in an arch or vault.

F

Face (1) Exposed surface of a wall or masonry unit. (2) Surface of a wall or masonry unit. (3) Surface of a unit designed to be exposed in the finished masonry.

Face-Bedded Stone set with the stratification vertical.

Face Shell Side wall of a hollow concrete masonry or clay masonry unit.

Face Shell Bedding Mortar is applied only to the horizontal surface of the face shells of hollow masonry units and in the head joints to a depth equal to the thickness of the face shell.

Facing Tile Structural clay tile for exterior and interior masonry with exposed faces (covered by ASTM C212 and ASTM C126).

Field Expanse of wall between openings, corners, etc., composed principally of stretcher units.

Fire Box Interior of a fireplace furnace, serving as combustion space.

Fire Clay Sedimentary clay of low flux content.

Fire Clay Mortar, Ground Refractory mortar consisting of finely ground raw fire clay.

- Fire Resistance** Property of a material or assemblage to withstand fire or give protection from it.
- Flagging** (1) Collective term for flagstones. (2) Surface paved with flagstones. (3) Process of setting flagstones.
- Flagstone** Type of stone that splits easily into flags or slabs; also a term applied to irregular pieces of such stone split into slabs from 1 to 3 in. thick, and used for walks, patios, etc.
- Flashing** (1) Impermeable material placed in masonry to provide water drainage or prevent water penetration. (2) Technique during brick firing to produce a range of colors by controlling the atmospheric conditions in the kiln.
- Flow** Laboratory-measured property of mortar that indicates the percent increase in diameter of the base of the truncated cone of mortar when it is placed on a flow table and mechanically raised and dropped a specified number of times under specified conditions.
- Flow after Suction** Flow of mortar measured after subjecting it to a vacuum to simulate suction of dry masonry units.
- Flue Lining** (1) Manufactured tubular non-loadbearing fired clay unit, normally used for conveying hot gases in chimneys. (2) Smooth, hollow clay or concrete tile unit used for the inner lining of masonry chimneys.
- Fly Ash** Finely divided residue resulting from the combustion of ground or powdered coal.
- Freeze-Thaw** Freezing and thawing of moisture in materials and the resultant effects on these materials and on structures of which they are a part or with which they are in contact.
- Fretwork** In masonry, any ornamental openwork or work in relief.
- Frog** Indentation in one bed surface of a brick, manufactured by molding or pressing.
- Furring** Method of finishing the interior face of a masonry wall to provide space for insulation, to prevent moisture transmittance, or to provide a smooth or plane surface for finishing.
- Furring Tile** Tile for lining the inside of walls and carrying no superimposed loads.
- Furring Unit** Thin masonry unit used as furring.
- Furrowing** Striking a V-shaped trough in a mortar bed.

G

- Glass Block** Hollow or solid glass masonry unit.
- Glaze** Hard, glassy, fused ceramic coating which may have a matte or glossy finish.

Clear Ceramic Glaze Ceramic glaze that is translucent or slightly tinted with a gloss finish.

Color Ceramic Glaze Opaque glaze of satin or gloss finish obtained by spraying the clay body with a compound of metallic oxides, chemicals, and clays.

Salt Glaze Lustrous glazed finish from thermochemical reaction of silicates of the clay body with vapors of salt or chemicals.

Gneiss Coarse-grained metamorphic rock with discontinuous foliation caused by planar alignment of platy- and lath-shaped minerals.

Gradation Particle size distribution of aggregate as determined by separation with standard screens. Gradation of aggregate is expressed in terms of the individual percentages passing standard screens. Sieve analysis, screen analysis, and mechanical analysis are terms used synonymously in referring to gradation of aggregate.

Granite Visibly granular, igneous rock generally ranging in color from pink to light or dark gray and consisting mostly of quartz and feldspars, accompanied by one or more dark minerals. The texture is typically homogeneous but may be gneissic or porphyritic. Some dark granular igneous rocks, though not geologically granite, are included in the definition.

“Green” Building Building structure that is designed, constructed, operated, and demolished in an environmentally enhanced manner.

“Green” Masonry Molded clay masonry unit before it has been fired in a kiln; an uncured concrete masonry unit.

Green Mortar Mortar that has set but not cured.

Greenstone Metamorphic rock, typically with poorly defined granularity, ranging in color from medium green or yellowish green to black.

Grid Paver Open-type masonry unit which allows grass to grow through openings, used for soil stabilization.

Ground Nailing strips placed in masonry walls as a means of attaching trim or furring.

Grout, Masonry Mixture of cementitious materials, aggregates, and water, with or without admixtures, used to fill voids in masonry; initially mixed to a consistency suitable for pouring or pumping without segregation of constituents.

Grout Lift (1) Increment of grout height within the total pour. A pour may consist of one or more lifts. (2) The height to which grout is placed in a cell, collar joint, or cavity without intermission.

Grout Pour Total height of a masonry wall to be grouted prior to erection of additional masonry. A grout pour will consist of one or more grout lifts.

Grout Pumping Method of installing masonry grout.

Grouted Hollow-Unit Masonry That form of grouted masonry construction in which certain designated cells of hollow units are continuously filled with grout.

Grouted Masonry Masonry construction composed of hollow units where designated hollow cells are filled with grout, or multi-wythe construction in which spaces between wythes are filled with grout.

Grouting, High-Lift Technique of grouting in which the masonry is constructed in excess of 5 ft high prior to grouting.

Grouting, Low-Lift Technique of grouting as the wall is constructed, usually to scaffold or bond beam height, but not greater than 4 ft.

H

Hard-Burned Nearly vitrified clay products which have been fired at high temperatures.

Head Joint See **Joint, Head**.

Header Masonry unit that overlaps two or more adjacent wythes of masonry to bind or tie them together. Also called a **header bond**. (1) Masonry unit that connects two or more adjacent wythes of masonry. (2) Masonry unit that overlaps two or more adjacent wythes of masonry to tie them together. Also called a **bonder**.

Header, Blind Concealed brick header in the interior of a wall, not showing on the faces.

Header, Clipped Bat that does not extend into the backup, placed to look like a header for purposes of establishing a pattern. Also called a false header.

Header Course Continuous bonding course of header brick. Also called a heading course.

Hearth (1) Masonry floor of a fireplace together with an adjacent area of fireproof material that may be a continuation of the flooring in the embrasure or some more decorative surfacing, as tile or marble. (2) Area permanently floored with fireproof material beneath and surrounding a stove.

Height of Wall Vertical distance from a foundation wall, or other similar intermediate support, to the top of a wall, or the vertical distance between intermediate supports.

Height-Thickness (*H/T*) Ratio Height of a masonry wall divided by its nominal thickness. The thickness of cavity walls is taken as the overall thickness minus the width of the cavity.

Hot-Weather Construction Procedures used in constructing masonry when ambient air temperature exceeds 100°F, or 90°F with a wind velocity greater than 8 mph.

Hysteresis Irreversible expansion of marble building stone with cycles of heating and cooling.

Igneous Rock Rock formed by change of the molten material called magma to the solid state.

IMI International Masonry Institute.

Initial Rate of Absorption (IRA) Measure of the capillary suction of water into a dry masonry unit from a bed face during a specified length of time over a specified area.

Initial Set Beginning change from a plastic to a hardened state.

Inspection Observation to verify that construction meets the requirements of the contract documents.

Interlocking Block Paver Solid masonry unit capable of transferring loads and stresses laterally by arching or bridging action between units when subjected to vehicular traffic.

Intrados Curve that bounds the lower side of an arch.

J

Joint In building construction, space or opening between two or more adjoining surfaces.

Mortar Joint In mortared masonry construction, joints between units that are filled with mortar.

Bed Joint Horizontal layer of mortar on which a masonry unit is laid.

Collar Joint Vertical, longitudinal joint between wythes of masonry or between masonry wythe and backing.

Head Joint Vertical transverse mortar joint placed between masonry units within the wythe at the time the masonry units are laid.

Raked Joint Mortar joint in which $\frac{1}{4}$ to $\frac{1}{2}$ in. of mortar is removed from the outside surface of the joint.

Shoved Joint Vertical joint filled by shoving a unit against the next unit when it is being laid in a bed of mortar.

Slushed Joint Head or collar joint constructed by “throwing” mortar in with the edge of a trowel.

Struck Joint Joint from which excess mortar has been removed by a stroke of the trowel, leaving an approximately flush joint.

Tooled Joint Mortar joint between two masonry units shaped manually or compressed with a jointing tool such as a concave or vee-notched jointer.

Movement Joint In building construction, a joint designed to accommodate movement of adjacent elements.

Control Joint (1) In concrete masonry, a continuous joint or plane to accommodate unit shrinkage; may contain mortar or grout. (2) In building construction, a formed, sawed, tooled, or assembled joint acting to regulate the location and degree of cracking and separation resulting from the dimensional change of different elements of a structure. (3) In concrete, concrete masonry, stucco, or coating systems, a formed, sawed, or assembled joint acting to regulate the location of cracking, separation, and distress resulting from dimensional or positional change.

Expansion Joint (1) Continuous joint or plane to accommodate expansion, contraction, and differential movement; does not contain mortar, grout, reinforcement, or other hard material. (2) In building construction, a structural separation between building elements that allows independent movement without damage to the assembly. (3) Discontinuity between two constructed elements or components, allowing for differential movement (such as expansion) between them without damage.

Saddle Joint Vertical joint along which the stone is lapped on either side to rise above the level of the wash on a coping or sill, thus diverting water from the joint.

Joint Reinforcement Metal bar or wire, usually prefabricated, to be placed in mortar bed joints.

Jointing Finishing of joints between courses of masonry units before the mortar has hardened.

K

Keystone Wedge-shaped stone at the center or summit of an arch or vault, binding the structure actually or symbolically.

Kiln A furnace, oven, or heated enclosure used for burning or firing brick or other clay material.

Kiln Run Bricks from the kiln that have not yet been sorted or graded for size or color variations.

King Closer Brick cut diagonally to have one 2-in. end and one full-width end.

L

Lap (1) The distance that one masonry unit extends over another. (2) The distance that one piece of flashing or reinforcement extends over another.

Lateral Support Bracing of walls, either vertically or horizontally, by columns, pilasters, cross walls, beams, floors, roofs, etc.

Lead Section of a wall built up and racked back on successive courses. A line is attached to leads as a guide for constructing a wall between them.

Leakage See **Water Leakage**.

Lewis Any of several metal devices for lifting stone blocks in a quarry or mill or for hoisting columns or other heavy masonry units in construction.

Lewis Bolt Bolt used to hang soffit stones or suspend the center part of a lintel. Conical or tapered and fit into slots cut from the back. It may also be leaded into stone, or combined with expansion sleeves. Carries the weight on an I-beam or other supporting member above.

Lewis Box Assembly of metal components, some or all of which are tapered upward, that is inserted into a downward-flaring hole (dovetail mortise) and cut into the tops of a column or other heavy masonry unit for hoisting.

Lewis Hole Opening cut or drilled into a stone block, column, or other heavy masonry unit to receive a lewis hoisting device. The shape and size of the hole vary with the lewis that is to be used.

Lewis Pin Metal peg, usually with its eye at the upper end, used for lifting a stone block or masonry unit. Lewis pins are used in pairs and are dependent on lever-action compression for gripping.

Lightweight Aggregate Aggregate of low density, such as expanded or sintered clay, shale, slate, diatomaceous shale, perlite, vermiculite, slag, natural pumice, scoria, volcanic cinders, tuff, diatomite, sintered fly ash, or industrial cinders.

Lime General term for the various chemical and physical forms of quicklime, hydrated lime, and hydraulic hydrated lime.

Hydrated Lime Quicklime to which sufficient water has been added to convert the oxides to hydroxides.

Lime Mortar Lime putty mixed with an aggregate, suitable for masonry purposes.

Lime Putty Product obtained by slaking quicklime with water according to the directions of the manufacturer or by mixing hydrated lime and water to a desired consistency.

Quicklime Hot, unslaked lime. A calcined material, a major part of which is calcium oxide (or calcium oxide in natural association with lesser amounts of magnesium oxide), capable of slaking with water.

Slaked Lime Formed when quicklime is treated with water; same as hydrated lime.

Limestone (1) Rock of sedimentary origin composed principally of calcium carbonate (the mineral calcite), or the double carbonate of calcium and magnesium (the mineral dolomite), or some combination of these two minerals. (a) *Oolitic Limestone* A limestone composed largely of spherical or sub-spherical particles called oolites or ooliths. (2) An initially sedimentary rock

consisting chiefly of calcium carbonate or of carbonates of calcium and magnesium. Limestone may be of high calcium, magnesium, or dolomite. (a) *Dolomitic Limestone* Limestone containing 35 to 46% magnesium carbonate ($MgCO_3$). (b) *Magnesium Limestone* Limestone containing 5 to 35% $MgCO_3$. (c) *High-Calcium Limestone* Limestone containing 0 to 5% $MgCO_3$.

Limestone Marble Compact, dense limestone that will take a polish is classified as marble in trade practice. Limestone marble may be sold as limestone or marble.

Line String stretched taut from lead to lead as a guide for laying the top edge of a masonry course.

Line Pin Metal pin used to attach line used for alignment of masonry units.

Lintel Beam placed or constructed over an opening in a wall to carry the superimposed load and the masonry above the opening.

Load, Allowable Permitted and projected safe load capacity through testing or calculated for a given structural element or combination of elements, including an acceptable safety factor for a given material.

M

Marble Carbonate rock that has acquired a distinctive crystalline texture by recrystallization, most commonly by heat and pressure during metamorphism, and is composed principally of the carbonate minerals calcite and dolomite, singly or in combination.

Mason Worker skilled in laying brick, tile, stone, or block.

Masonry (1) Construction, usually set in mortar, of natural building stone or manufactured units such as brick, concrete block, adobe, glass block, tile, manufactured stone, or gypsum block. (2) Assemblage of structural clay masonry units, concrete masonry units, stone, etc., or combination thereof, bonded with mortar or grout. (3) Construction of brick, block, or stone that is set in mortar, dry-stacked, or anchored mechanically.

Masonry Cement Hydraulic cement for use in mortars for masonry construction, containing one or more of the following materials: portland cement, portland blast-furnace slag cement, portland-pozzolan cement, natural cement, slag cement, or hydraulic lime; and in addition usually containing one or more materials such as hydrated lime, limestone, chalk, calcareous shell, talc, slag, or clay, as prepared for this purpose.

Masonry Cement Mortar Mortar produced using masonry cement.

Masonry Unit (1) Manufactured material, such as brick, concrete block, structural tile, or stone, suitable for the construction of masonry. (2) Natural or manufactured building unit of clay, concrete, stone, glass, or calcium silicate.

Masonry Unit, Clay Hollow or solid masonry unit of clay or shale, including clay brick, structural clay tile, and adobe brick.

Masonry Unit, Concrete Manufactured masonry unit made from portland cement, mineral aggregates, and water, with or without the inclusion of other materials.

Masonry Unit, Hollow Masonry unit whose net cross-sectional area in any plane parallel to the bearing surface is less than 75% of its gross cross-sectional area measured in the same plane.

Masonry Unit, Modular Masonry unit whose nominal dimensions are based on a 4-in. module.

Masonry Unit, Solid Masonry unit whose net cross-sectional area in any plane parallel to the bearing surface is 75% or more of its gross cross-sectional area measured in the same plane.

Mason's Hammer Hammer with a heavy steel head, one face of which is shaped like a chisel, for trimming brick or stone.

Mason's Level Similar to a carpenter's level, but longer.

Mechanical Bond Tying masonry units together with metal ties, reinforcing steel, or keys.

Metamorphic Rock Rock altered in appearance, density, and crystalline structure, and in some cases mineral composition, by high temperature or high pressure or both.

Mix Design Proportions of ingredients to produce mortar, grout, or concrete.

Mixer Machine employed for blending the constituents of concrete, grout, mortar, or other mixtures.

Modular Coordination Dimensional coordination of masonry and other construction components through the use of standard incremental units.

Modulus of Elasticity Ratio of normal stress to corresponding strain for tensile or compressive stresses below proportional limit of material.

Moisture Content Amount of water contained in a material, expressed as a percentage of total absorption.

Mortar Mixture of cementitious materials, fine aggregate, and water, with or without admixtures, used to construct masonry.

Fat Mortar Mortar mixture containing a high ratio of binder to aggregate.

Harsh Mortar Mortar that is difficult to spread; not workable.

Lean Mortar Mortar that is deficient in cementitious components, usually harsh and difficult to spread.

Ready-Mixed Mortar Mortar consisting of cementitious materials, aggregate, water, and set-control admixtures which are measured and mixed at a central location, using weight- or volume-control equipment. This mortar as delivered to a construction site is generally usable for a period in excess of 2½ hours.

Surface Bonding Mortar Product containing hydraulic cement, glass fiber reinforcement with or without inorganic fillers, or organic modifiers in a prepackaged form, requiring only the addition of water prior to application.

Mortar Bedding Construction of masonry assemblages with mortar.

Mortar Board Board, approximately 3 ft square in area, to hold mortar ready for the use by a mason.

Mortar Joint See **Joint, Mortar**.

Movement Joint See **Joint, Movement, Control, and Joint, Movement, Expansion**.

N

NBS National Bureau of Standards.

NCMA National Concrete Masonry Association.

Neat Cement In masonry, a pure cement undiluted by sand aggregate or admixtures.

Net Cross-Sectional Area Gross cross-sectional area of a unit minus the area of cores or cellular spaces.

NFPA National Fire Protection Association.

Noncombustible (1) Not combustible. (2) Any material that will neither ignite nor actively support combustion in air at a temperature of 1200°F when exposed to fire.

O

Overhand Work Masonry laid from the interior side of a wall rather than from the exterior side.

P

Parging Application of a coat of cement mortar to the back of the facing or the face of the backing in multi-wythe construction.

Paver Paving stone, brick, or concrete masonry unit.

Paving, Unit Vehicular or pedestrian traffic surfacing of unit masonry pavers.

Paving Brick See **Brick, Paving**.

Paving Stone Stone used in exterior pedestrian-wearing surfaces, such as patios, walkways, driveways, and the like.

PCA Portland Cement Association.

Pendentive Triangular segment of vaulting used to effect a transition at the angles from a square or polygon base to a dome above.

Perlite (1) Aggregate used in lightweight insulating concrete, concrete masonry units, and plaster. (2) Insulation composed of natural perlite ore expanded to form a cellular structure.

Permeability Property of allowing passage of fluids.

Pick-and-Dip Method of laying brick whereby the bricklayer simultaneously picks up a brick with one hand and, with the other hand, enough mortar on a trowel to lay the brick. Sometimes called the Eastern, New England, or English method.

Pier Isolated column of masonry, or a bearing wall not bonded at the sides to associated masonry.

Pilaster Portion of a wall serving as an integral vertical column and usually projecting from one or both wall faces. Sometimes called a **pier**.

Pilaster Block Concrete masonry unit designed for use in construction of plain or reinforced concrete masonry pilasters and columns.

Plasticizer Substance incorporated into a material to increase its workability, flexibility, or extensibility.

Point (1) A wedge-shaped or pyramidal chisel. (2) To engage in the act of "pointing" mortar joints.

Pointing Troweling mortar into a joint after the masonry units are laid.

Repointing Filling in cut-out or defective mortar joints in masonry with fresh mortar.

Tuckpointing Decorative method of pointing masonry with a surface mortar that is different from the bedding mortar.

Portland Cement Hydraulic cement produced by pulverizing portland cement clinker, and usually containing calcium sulfate.

Prefabricated Masonry Masonry fabricated at a location other than its final location in the structure. Also known as preassembled, panelized, and sectionalized masonry.

Prefabrication To fabricate the parts at a factory or on site so that construction consists mainly of assembling and utilizing standard parts in a building structure.

Preservation, Building

Conservation Management of a natural resource, structure, or artifact to prevent misuse, destruction, or neglect. It may include detailed characterization and recording (technical or inventory) or provenance and history and application of measures.

Preservation Act or process of applying measures to sustain the existing form, integrity, or materials of a building, structure, or artifact and the existing form or vegetative cover of a site.

Protection Act or process of applying measures designed to affect the physical condition of a building, structure, or artifact by guarding it from deterioration, loss, or attack; or, to cover or shield it from damage.

Rehabilitation, of a Structure Act or process of returning a structure to a state of utility through repair or alteration which makes possible an efficient contemporary use.

Restoration Act or process of reestablishing accurately the form and details of a structure, site, or artifact as it appeared at a particular period in time, by means of removal of later work or by the reconstruction of missing earlier work.

Prism Assemblage of masonry units and mortar with or without grout, used as a test specimen for determining properties of the masonry.

Prism Strength Maximum compressive strength (force) resisted per unit of net cross-sectional area of masonry, determined by testing masonry prisms.

Prism Testing Testing an assemblage of masonry units, mortar, or grout to determine the compressive strength of masonry.

Productivity (1) Rate of production of masonry materials or assemblies. (2) Number of masonry units that a mason can install in a building structure during a given period of time.

Pumice Material of volcanic origin, being of cellular structure and highly porous, which is used as an aggregate for lightweight concrete or concrete masonry units.

Q

Quarry An open excavation at the earth's surface for the purpose of extracting usable stone.

Quarry Run Unselected materials of building stone within the ranges of color and texture available from the source quarry.

Quarry Sap Colloquial term for the natural moisture in stone as it comes from the quarry ledge. Varies in amount with the porosity of the structure.

Quartzite Geologically, metamorphic rock resulting from the annealing of quartz sandstone. See also **Sandstone, Quartzite**.

Queen Closer Cut brick having a nominal 2-in. horizontal face dimension.

Quoin Projecting courses of brick or stone at the corners and angles of buildings as ornamental features.

R

Racking Stepping back successive courses of masonry.

Racking Test Laboratory test for shear strength of masonry wall panels measured as diagonal tension.

Rain Penetration See **Water Penetration**.

R.B.M. Reinforced brick masonry.

Reglet (1) Groove or recess to receive and secure metal flashing. (2) Groove in a wall or other surface adjoining a roof surface for the attachment of counterflashing.

Reinforced Masonry Masonry units and reinforcing steel bonded with mortar and/or grout in such a manner that the components act together in resisting forces.

Repointing See **Pointing**.

Retempering To add more water to a hydraulic-setting compound after the initial mixing, but before partial set has occurred.

Retrofit In building, to add new materials or equipment not provided at the time of the original construction.

Riprap Irregularly broken and random-sized large pieces of rock.

Rowlock Brick laid on its face edge with the end surface visible in the wall face. Frequently spelled rolok.

Rustic (1) Masonry, generally of local stone, that is roughly hand dressed, and intentionally laid with high relief in relatively modest structures of rural character. (2) A grade of building limestone characterized by coarse texture.

Rustic Joint A deeply sunk mortar joint that has been emphasized by having the edges of the adjacent stones chamfered or recessed below the surface of the face. Also called rusticated joint.

Rusticated Cut stone with strongly emphasized recessed joints and smooth or roughly textured block faces. The border of each block may be rebated, chamfered, or beveled on all four sides, at top and bottom only, or on two adjacent sides. The face of the block may be flat, pitched, or diamond point, and if smooth, may be hand or machine tooled.

S

Sand-Rubbed Finish Type of stone surface obtained by rubbing with a sand-and-water mixture under a block. Commonly applied with a rotary or belt sander.

Sandstone Sedimentary rock composed mostly of mineral and rock fragments within the sand size range (2 to 0.06 mm) and having a minimum of 60% free silica, cemented or bonded to a greater or lesser degree by vari-

ous materials including silica, iron oxides, carbonates, or clay, and which fractures around (not through) the constituent grains.

Quartzite Highly indurated, typically metamorphosed sandstone containing at least 95% free silica, which fractures conchoidally *through* the grains.

Quartzitic Sandstone Sandstone containing at least 90% free silica (quartz grains plus siliceous cement), which may fracture *around or through* the constituent grains.

Saturation Coefficient Ratio of the weight of water absorbed by a masonry unit when immersed 24 hours in cold water to the weight of water absorbed after an additional immersion for 5 hours in boiling water. An indication of the probable resistance of brick to freezing and thawing. Also called **C/B ratio**.

SCPI Structural Clay Products Institute, now called Brick Industry Association (**BIA**).

SCR Trademark of the Brick Institute of America.

SCR Brick Brick whose nominal dimensions are $6 \times 2\frac{2}{3} \times 12$ in.

SCR Masonry Process Process providing greater efficiency, better workmanship, and increased production in masonry construction using story poles, marked lines, and adjustable scaffolding.

Screen Tile Clay tile manufactured for masonry screen wall construction.

Sedimentary Rock Rock formed from materials deposited as sediments in the sea or fresh water, or on land. The materials are transported to their site of deposition by running water, wind, moving ice, marine energy, or gravitational movements, and they may deposit as fragments or by precipitation from solution.

Serpentine Marble Rock consisting mostly or entirely of serpentine (hydrated magnesium silicate), green to greenish black in color, and commonly veined with calcite, and dolomite or magnesite, or both (magnesium carbonate).

Set Change in consistency from a plastic to a hardened state.

Shale (1) Thinly stratified, consolidated, sedimentary clay with well-marked cleavage parallel to the bedding. (2) Laminated sedimentary rock composed of clay minerals.

Shelf Angle Metal angle attached to a structural member, used to support masonry.

Shrinkage Volume change due to loss of moisture or decrease in temperature.

Side-Construction Tile Structural clay tile intended for placement with the axis of the cells horizontal.

Skewback Inclined surface on which an arch joins the supporting wall.

Slate Microcrystalline metamorphic rock most commonly derived from shale and composed mostly of micas, chlorite, and quartz. The micaceous minerals have a subparallel orientation and thus impart strong cleavage to the rock, which allows the latter to be split into thin but tough sheets.

Slenderness Ratio (1) Effective unsupported length of a uniform column divided by the least radius of gyration of the cross-sectional area. (2) Ratio of the effective height of a wall or column to its effective thickness; used as a means of assessing the stability of a masonry wall or column.

Smoke Chamber Space in a fireplace immediately above the throat, where the smoke gathers before passing into the flue; narrowed by corbelling to the size of the flue lining above.

Soap Masonry unit of normal face dimension, having a nominal 2-in. thickness.

Soapstone Massive soft rock that contains a high proportion of talc and that is cut into dimension stone.

Soffit The underside of a beam, lintel, or arch.

Solar Screen Perforated wall used as a sunshade.

Soldier Stretcher set on end, with the face showing on the wall surface.

Spall (1) To break away protrusions or edges on stone blocks with a sledge. (2) To flake or split away through frost action or pressure. (3) A chip or flake.

Specified Compressive Strength of Masonry, f'_m Minimum compressive strength expressed as force per unit of net cross-sectional area required of the masonry used in construction by the project documents, and on which the project design is based. Whenever the quantity f'_m is under a radical sign, the square root of the numerical value only is intended, and the result has units of pounds per square inch (psi).

Squinch Arch or corbelling at the upper interior corner of a square tower for support of a circular or octagonal superstructure.

Stone

Building Stone Natural rock of adequate quality to be quarried and cut as dimension stone, as it exists in nature, and used in the construction industry.

Cast Stone Architectural precast concrete building unit intended to simulate natural cut stone.

Cut Stone Stone fabricated to specific dimensions.

Dimension Stone Natural stone that has been selected, trimmed, or cut to specified or indicated shapes or sizes, with or without one or more mechanically dressed surfaces.

Fieldstone Natural building stone as found in the field.

Finished Stone Dimension stone with one or more mechanically dressed surfaces.

Flagstone Flat stone, thin in relation to its surface area, commonly used as a stepping stone, for a terrace or patio, or for floor paving. Usually either naturally thin or split from rock that cleaves readily.

Stone Masonry Masonry composed of natural or cast stone.

Stone Masonry, Ashlar Stone masonry composed of rectangular units having sawed, dressed, or squared bed surfaces and bonded by mortar.

Ashlar Pattern Pattern bond of rectangular or square stone units, always of two or more sizes. If the pattern is repeated, it is patterned ashlar. If the pattern is not repeated, it is random ashlar.

Coursed Ashlar Ashlar masonry laid in courses of stone of equal height for each course, although different courses may be of varying height.

Random Ashlar Stone masonry pattern of rectangular stones set without continuous joints and laid up without drawn patterns. If composed of material cut to modular heights, discontinuous but aligned horizontal joints are discernible.

Stone Masonry, Rubble Stone masonry composed of irregularly shaped units bonded by mortar.

Coursed Rubble Masonry composed of roughly shaped stones fitting on approximately level beds, well bonded, and brought at vertical intervals to continuous level beds or courses.

Random Rubble Masonry wall built of unsquared or rudely squared stones that are irregular in size and shape.

Squared Rubble Wall construction in which squared stones of various sizes are combined in patterns that make up courses as high as, or higher than, the tallest stones.

Stonemason Building craftsman skilled in constructing stone masonry.

Story Pole Marked pole for measuring masonry coursing during masonry construction.

Stretcher Masonry unit laid with its greatest dimension horizontal and its face parallel to the wall face.

Strike To remove excess mortar from the surface of a joint by cutting it flush with the unit surface using the edge of a trowel. See also **Tooling**.

String Course Horizontal band of masonry, generally narrower than other courses, extending across the facade of a structure and in some structures encircling such decorative features as pillars or engaged columns.

Stringing Mortar Procedure of spreading enough mortar on a bed to lay several masonry units.

Structural Clay Tile Hollow masonry building unit composed of burned clay, shale, fire clay, or combinations of these materials.

End-Construction Tile Tile designed to be laid with the axis of its cells vertical.

Facing Tile Tile for exterior and interior masonry with exposed faces.

Fireproofing Tile Tile designed for protecting steel structural members from fire.

Side-Construction Tile Tile intended for placement with the axis of the cells horizontal.

Suction See **Initial Rate of Absorption**.

Surface Bonded Masonry Bonding of masonry units by parging with a thin layer of fiber-reinforced mortar.

Surface Bonding Mortar Product containing hydraulic cement, glass fiber reinforcement with or without inorganic fillers, or organic modifiers in a prepackaged form, requiring only the addition of water prior to application.

Sustainable Architecture/Design Building design that fulfills the needs of the current generation without limiting the ability of future generations to produce what they need to sustain themselves.

T

Temper (1) In hydraulic setting compounds, to bring to a usable state by mixing in or adding water. (2) To moisten and mix mortar to a proper consistency.

Terra Cotta A fired clay product used for ornamental work.

Tie See **Connector, Tie**.

Thermal Inertia Lag time required for a mass to heat or cool.

Thermal Mass Dense material capable of absorbing and storing heat.

Thermal Resistance The reciprocal of thermal transmittance (expressed by the notation R).

Tolerance Specified allowance of variation from a size specification.

Tooling Compressing and shaping the surface of a mortar joint. See also **Strike**.

Toothing Constructing the temporary end of a wall with the end stretcher of every alternate course projecting. Projecting units are toothers.

Travertine Variety of crystalline or microcrystalline limestone distinguished by layered structure. Pores and cavities commonly are concentrated in some of the layers, giving rise to an open texture.

Travertine Marble Porous or cellularly layered, partly crystalline calcite of chemical origin.

Tuckpointing See **Pointing**.

U

UBC Uniform Building Code.

Unit Masonry Construction of brick or block that is set in mortar, dry-stacked, or mechanically anchored.

Unreinforced Masonry (1) Masonry whose tensile resistance is considered in design, and the resistance of any reinforcing steel present is neglected. (2) Masonry constructed without steel reinforcement, except that which may be used for bonding or reducing the effects of dimensional changes due to variations in moisture content or temperature.

V

Veneer A single facing wythe of masonry, anchored or adhered to a structural backing, but not designed to carry axial loads.

Vermiculite Micaceous aggregate used in lightweight insulating concrete, concrete masonry units, and plaster. (2) Insulation composed of natural vermiculite ore expanded to form an exfoliated structure.

Virtual Eccentricity Eccentricity of a resultant axial load required to produce axial and bending stresses equivalent to those produced by applied axial loads and moments. It is normally found by dividing the moment at a section by the summation of axial loads occurring at the section.

Vitrification Progressive reduction in porosity of a ceramic composition as a result of heat treatment, or the process involved.

Vousoir One of the truncated, wedge-shaped masonry units which form an arch ring.

W

Wall (1) Vertical element with a horizontal length-to-thickness ratio greater than 3, used to enclose space.

Bearing Wall Wall supporting a vertical load in addition to its own weight.

Bonded Wall Masonry wall in which two or more wythes are bonded to act as a structural unit.

Composite Wall Multi-wythe wall in which at least one of the wythes is dissimilar to the other wythe or wythes with respect to type of masonry unit.

Curtain Wall Nonbearing exterior wall, secured to and supported by the structural members of the building.

Masonry Bonded Hollow Wall Wall with an internal air space, the facing and backing wythes of which are connected with masonry headers.

Multi-Wythe Wall Masonry wall composed of two or more wythes.

Panel Wall Exterior non-loadbearing wall wholly supported at each story.

Parapet Wall That part of any wall that is entirely above the roof.

Partition Wall Interior wall one story or less in height. It is generally non-loadbearing. In Canada, partition means an interior wall of one-story or part-story height that is never loadbearing.

Perforated Wall See **Wall, Screen**.

Pierced Wall See **Wall, Screen**.

Prestressed Wall Reinforced concrete or masonry wall in which internal stresses have been introduced to reduce potential tensile stresses in the wall resulting from imposed loads.

Retaining Wall Wall that does not enclose a portion of a building; designed to resist the lateral displacement of soil or other material.

Screen Wall Masonry wall in which an ornamental pierced effect is achieved by alternating rectangular or shaped blocks with open spaces.

Serpentine Wall Wall that is sine wave in plan.

Single-Wythe Wall Masonry wall that is only one unit in thickness.

Solid Masonry Wall Wall built of solid masonry units, laid contiguously, or with the collar joint between the units filled with mortar or grout.

Trombe Wall Masonry wall designed to absorb solar heat and release it into the interior of a building.

Water Absorption Process in which water enters a material or system through capillary pores and interstices and is retained without transmission.

Water Infiltration Process in which water passes through a material or system and reaches an area that is not directly or intentionally exposed to the water source.

Water Leakage Water infiltration that is unintended or uncontrolled, exceeds the resistance, retention, or discharge capacity of the system, or causes damage or accelerated deterioration.

Water Penetration Process in which water enters a material or system through an exposed surface, joint, or opening.

Water Permeation Process in which water enters, flows within, and spreads throughout a material or system.

Water Repellant Material or treatment for surfaces, to provide resistance to penetration by water.

Water Retentivity That property of a mortar which prevents the rapid loss of water to masonry units of high suction. It prevents bleeding or water gain when mortar is in contact with relatively impervious units.

Water Saturation Maximum amount of water a material or system can retain without discharge or transmission.

Water Vapor Permeance Time rate of water vapor transmission through unit area of a flat material or construction induced by unit vapor pressure difference between two specified surfaces, under specified temperature and humidity conditions.

Waterproof Impervious to water.

Waterproofing (1) Treatment of a surface or structure to prevent the passage of water under hydrostatic pressure. (2) In building construction, treatment of a surface or structure to prevent the passage of liquid water under hydrostatic, dynamic, or static pressure.

Weep Hole (1) Opening in mortar joints or faces of masonry units to permit the escape of moisture. (2) A small hole allowing drainage of fluid.

Wind-Driven Rain Rain driven by the wind.

Workability Ability of mortar to be easily placed and spread.

Workmanship The art or skill of a worker; craftsmanship; the quality imparted to a thing in the process of creating it.

Wythe (1) Each continuous vertical section of a wall, one masonry unit in thickness. (2) The portion of a wall which is one masonry unit in thickness. A collar joint is not considered a wythe.

This page intentionally left blank.

Appendix

B

ASTM REFERENCE STANDARDS

The following reference standards of the American Society for Testing and Materials (ASTM) are related to masonry products, testing, and construction.

Clay Masonry Units

ASTM C27, *Fire Clay and High Alumina Refractory Brick*

ASTM C32, *Sewer and Manhole Brick*

ASTM C34, *Structural Clay Loadbearing Wall Tile*

ASTM C43, *Terminology Relating to Structural Clay Products*

ASTM C56, *Structural Clay Non-Loadbearing Tile*

ASTM C62, *Building Brick*

ASTM C106, *Fire Brick Flue Lining for Refractories and Incinerators*

ASTM C126, *Ceramic Glazed Structural Clay Facing Tile, Facing Brick, and Solid Masonry Units*

ASTM C155, *Insulating Fire Brick*

ASTM C212, *Structural Clay Facing Tile*

ASTM C216, *Facing Brick*

ASTM C279, *Chemical Resistant Brick*

ASTM C315, *Clay Flue Linings*

ASTM C410, *Industrial Floor Brick*

ASTM C416, *Silica Refractory Brick*

ASTM C530, *Structural Clay Non-Loadbearing Screen Tile*
ASTM C652, *Hollow Brick*
ASTM C902, *Pedestrian and Light Traffic Paving Brick*
ASTM C1261, *Firebox Brick for Residential Fireplaces*
ASTM C1272, *Standard Specification for Heavy Vehicular Paving Brick*
ASTM C1405, *Glazed Brick (Single Fired, Solid Brick Units)*

Cementitious Masonry Units

ASTM C55, *Concrete Building Brick*
ASTM C73, *Calcium Silicate Face Brick (Sand-Lime Brick)*
ASTM C90, *Loadbearing Concrete Masonry Units*
ASTM C129, *Nonloadbearing Concrete Masonry Units*
ASTM C139, *Concrete Masonry Units for Construction of Catch Basins and Manholes*
ASTM C744, *Prefaced Concrete and Calcium Silicate Masonry Units*
ASTM C936, *Solid Concrete Interlocking Paving Units*
ASTM C1319, *Concrete Grid Paving Units*
ASTM C1364, *Architectural Cast Stone*
ASTM C1372, *Segmental Retaining Wall Units*
ASTM C1386, *Precast Autoclaved Aerated Concrete (PAAC) Wall Construction Units*
ASTM C1452, *Reinforced Autoclaved Aerated Concrete Elements*

Natural Stone

ASTM C119, *Terminology Relating to Dimension Stone*
ASTM C503, *Marble Dimension Stone*
ASTM C568, *Limestone Dimension Stone*
ASTM C615, *Granite Dimension Stone*
ASTM C616, *Quartz-Based Dimension Stone*
ASTM C629, *Slate Dimension Stone*

Mortar and Grout

ASTM C5, *Quicklime for Structural Purposes*
ASTM C33, *Aggregates for Concrete*
ASTM C91, *Masonry Cement*
ASTM C144, *Aggregate for Masonry Mortar*
ASTM C150, *Portland Cement*
ASTM C199, *Pier Test for Refractory Mortar*
ASTM C207, *Hydrated Lime for Masonry Purposes*
ASTM C270, *Mortar for Unit Masonry*
ASTM C330, *Lightweight Aggregates for Structural Concrete*
ASTM C331, *Lightweight Aggregates for Concrete Masonry Units*
ASTM C404, *Aggregates for Masonry Grout*
ASTM C476, *Grout for Reinforced and Nonreinforced Masonry*
ASTM C658, *Chemical Resistant Resin Grouts*
ASTM C887, *Packaged, Dry, Combined Materials for Surface Bonding Mortar*
ASTM C1142, *Extended Life Mortar for Unit Masonry*
ASTM C1329, *Mortar Cement*
ASTM C1384, *Modifiers for Masonry Mortar*

Reinforcement and Accessories

- ASTM A82, *Cold Drawn Steel Wire for Concrete Reinforcement*
ASTM A153, *Zinc Coating (Hot-Dip) on Iron or Steel Hardware*
ASTM A165, *Electro-Deposited Coatings of Cadmium on Steel*
ASTM A167, *Stainless and Heat Resisting Chromium-Nickel Steel Plate, Sheet and Strip*
ASTM A185, *Welded Steel Wire Fabric for Concrete Reinforcement*
ASTM A496, *Deformed Steel Wire for Concrete Reinforcement*
ASTM A615, *Deformed and Plain Billet-Steel Bars for Concrete Reinforcement*
ASTM A616, *Rail-Steel Deformed and Plain Bars for Concrete Reinforcement*
ASTM A617, *Axle-Steel Deformed and Plain Bars for Concrete Reinforcement*
ASTM A641, *Standard Specification for Zinc Coated (Galvanized) Carbon Steel Wire*
ASTM A951, *Masonry Joint Reinforcement for Masonry*
ASTM B227, *Hard-Drawn Copper-Covered Steel Wire, Grade 30HS*
ASTM C1242, *Guide for Design, Selection and Installation of Exterior Dimension Stone Anchors and Anchoring Systems*
ASTM C1472, *Guide for Calculating Movement and Other Effects When Establishing Sealant Joint Width*

Sampling and Testing

- ASTM C67, *Sampling and Testing Brick and Structural Clay Tile*
ASTM C97, *Absorption and Bulk Specific Gravity of Natural Dimension Stone*
ASTM C109, *Method of Test for Compressive Strength of Hydraulic Cement Mortars*
ASTM C140, *Sampling and Testing Concrete Masonry Units*
ASTM C170, *Compressive Strength of Natural Dimension Stone*
ASTM C241, *Method of Test for Abrasion Resistance of Stone*
ASTM C267, *Chemical Resistance of Mortars, Grouts and Monolithic Surfacing*
ASTM C426, *Test Method for Drying Shrinkage of Concrete Block*
ASTM C780, *Prognostication and Construction Evaluation of Mortars for Plain and Reinforced Unit Masonry*
ASTM C880, *Flexural Strength of Natural Dimension Stone*
ASTM C952, *Method of Test for Bond Strength of Mortar to Masonry Units*
ASTM C1006, *Test Method for Splitting Tensile Strength of Masonry Units*
ASTM C1019, *Sampling and Testing Grout*
ASTM C1028, *Determining the Static Coefficient of Friction of Ceramic Tile and Other Like Surfaces by the Horizontal Dynamometer Pull-Meter Method* (used to measure slip-resistance of stone flooring and paving)
ASTM C1072, *Method of Measurement of Masonry Flexural Bond Strength*
ASTM C1093, *Accreditation of Testing Agencies for Unit Masonry*
ASTM C1148, *Test Method for Measuring the Drying Shrinkage of Masonry Mortar*
ASTM C1194, *Compressive Strength of Architectural Cast Stone*
ASTM C1195, *Absorption of Architectural Cast Stone*
ASTM C1196, *In Situ Compressive Stress within Solid Unit Masonry Estimated Using Flatjack Method*
ASTM C1197, *In Situ Measurement of Masonry Deformability Using the Flatjack Method*

ASTM C1262, *Evaluating the Freeze-Thaw Durability of Manufactured Concrete Masonry and Related Concrete Units*
ASTM C1314, *Method of Constructing and Testing Masonry Prisms Used to Determine Compliance with Specified Compressive Strength of Masonry*
ASTM C1324, *Examination and Analysis of Hardened Masonry Mortar*
ASTM C1357, *Methods for Evaluating Masonry Bond Strength*
ASTM D75, *Sampling Aggregates*
ASTM E72, *Conducting Strength Tests of Panels for Building Construction*
ASTM E447, *Test for Compressive Strength of Masonry Prisms*
ASTM E488, *Strength of Anchors in Concrete and Masonry Elements*
ASTM E514, *Test Method for Water Permeance of Masonry*
ASTM E518, *Test for Flexural Bond Strength of Masonry*
ASTM E519, *Test for Diagonal Tension in Masonry Assemblages*
ASTM E754, *Pullout Resistance of Ties and Anchors Embedded in Masonry Mortar Joints*

Assemblages

ASTM C901, *Prefabricated Masonry Panels*
ASTM C946, *Construction of Dry Stacked, Surface Bonded Walls*
ASTM E835, *Guide for Dimensional Coordination of Structural Clay Units, Concrete Masonry Units, and Clay Flue Linings*
ASTM C1283, *Standard Practice for Installing Clay Flue Lining*
ASTM C1400, *Guide for Reduction of Efflorescence Potential in New Masonry Walls*
ASTM E1602, *Guide for the Construction of Solid Fuel-Burning Masonry Heaters*

Bibliography

- ALLEN, EDWARD. *Fundamentals of Building Construction*. New York: John Wiley & Sons, 1999.
- ALLEN, EDWARD. *Stone Shelters*. Cambridge, MA: The MIT Press, 1969.
- AMERICAN INSTITUTE OF ARCHITECTS. *General Conditions of the Contract for Construction*, AIA Document A201, 1997 ed. American Institute of Architects, Washington, DC.
- AMERICAN SOCIETY OF HEATING, REFRIGERATING AND AIR CONDITIONING ENGINEERS. *Fundamentals*, ASHRAE Handbook. Atlanta: ASHRAE, 1989.
- AMRHEIN, JAMES E. *Grout...The Third Ingredient*. Los Angeles: Masonry Institute of America, 1980.
- AMRHEIN, JAMES E. *Reinforced Masonry Engineering Handbook*. 5th ed. Los Angeles: Masonry Institute of America, 1992.
- AMRHEIN, JAMES E. *Steel in Masonry*. Los Angeles: Masonry Institute of America, 1977.
- AMRHEIN, JAMES E., ET AL. *Masonry Design Manual*, 3d ed. Los Angeles: Masonry Industry Advancement Committee, 1979.
- AMRHEIN, JAMES E., AND MICHAEL W. MERRIGAN. *Marble and Stone Slab Veneer*, 2d ed. Los Angeles: The Masonry Institute of America, 1989.

- AMRHEIN, JAMES E., AND MICHAEL W. MERRIGAN. *Reinforced Concrete Masonry Construction Inspector's Handbook*, 2d ed. Los Angeles: The Masonry Institute of America and the International Conference of Building Officials, 1989.
- ARUMI, FRANCISCO N. *Thermal Inertia in Architectural Walls*. Herndon, VA: National Concrete Masonry Association, 1977.
- BALCOMB, J. DOUGLAS, ET AL. *Passive Solar Design Handbook*. Sacramento, CA: Solar Energy Information Services, 1981.
- BALLAST, DAVID KENT. *Handbook of Construction Tolerances*. New York: McGraw-Hill, 1994.
- BEALL, CHRISTINE. *Masonry and Concrete for Residential Construction*. New York: McGraw-Hill Complete Construction Series, 2001.
- BEALL, CHRISTINE. *Thermal and Moisture Protection Manual*. New York: McGraw-Hill, 1999.
- BEALL, CHRISTINE, AND ROCHELLE JAFFE. *Concrete and Masonry Databook*. New York: McGraw-Hill, 2003.
- BELL, JOSEPH, ET AL. *From the Carriage Age...To the Space Age*. Herndon, VA: National Concrete Masonry Association, 1970.
- BERRYMAN, NANCY D., AND SUSAN M. TINDALL. *Terra Cotta: Preservation of an Historic Material*. Chicago: Landmarks Preservation Council of Illinois, 1984.
- BORCHELT, J. GREGG, ED. *Masonry: Materials, Properties, and Performance*, ASTM STP 778. Philadelphia: American Society for Testing and Materials, 1982.
- BOUDREAU, EUGENE H. *Making the Adobe Brick*. Berkeley: Fifth Street Press, 1971.
- BRICK INDUSTRY ASSOCIATION. *Recommended Practice for Engineered Brick Masonry*. Reston, Va., 1969.
- BRICK INDUSTRY ASSOCIATION. *Bricklaying Brick and Block Masonry*. Reston, VA: BIA, 1988.
- BRICK INDUSTRY ASSOCIATION. *Principles of Brick Masonry*. Reston, VA: BIA, 1989.
- BRICK INDUSTRY ASSOCIATION. *Technical Notes on Brick Construction*, Nos. 1-45. Reston, VA: BIA.
- CANADIAN HOMEBUILDERS ASSOCIATION. *Builder's Manual*. Ottawa, Ontario: CHBA, 1994.
- CAST STONE INSTITUTE. *Technical Manual with Case Histories*. Tucker, GA: Cast Stone Institute.
- CATANI, MARIO J., AND STANLEY E. GOODWIN. "Heavy Building Envelopes and Dynamic Thermal Response," *Journal of the American Concrete Institute*, February 1976.
- CLIFTON, JAMES R., ED. *Cleaning Stone and Masonry*, ASTM STP 935. Philadelphia: American Society for Testing and Materials, 1986.
- COLLINS, GEORGE R. *Antonio Gaudi*. New York: George Braziller, 1960.
- CONDIT, CARL W. *American Building*. Chicago: University of Chicago Press, 1968.

- CONDIT, CARL W. *The Rise of the Skyscraper*. Chicago: University of Chicago Press, 1952.
- CONSTRUCTION SPECIFICATIONS INSTITUTE AND ASSOCIATION FOR PRESERVATION TECHNOLOGY INTERNATIONAL. *Guide to Preparing Design and Construction Documents for Historic Projects* (CSI Document TD-2-8). Alexandria, VA: CSI, 1996.
- CONSTRUCTION SPECIFICATIONS INSTITUTE. *Manual of Practice*. Alexandria, VA: CSI, 1992/1994.
- CONSTRUCTION SPECIFICATIONS INSTITUTE. *MasterFormat™ Master List of Titles and Numbers for the Construction Industry*. Alexandria, VA: Construction Specifications Institute and Construction Specifications Canada, 1988.
- CONSTRUCTION SPECIFICATIONS INSTITUTE. *SpecGUIDE 04290 Adobe Unit Masonry*. Alexandria, VA: CSI, 1994.
- COX, WARREN J. *Brick Architectural Details*. Reston, VA: Brick Institute of America, 1973.
- DALZELL, J. RALPH. *Simplified Concrete Masonry Planning and Building*. New York: McGraw-Hill, 1972.
- DAVEY, NORMAN A. *A History of Building Materials*. London: Phoenix House, 1961.
- DAVIS, GERALD, ED. *Building Performance: Function, Preservation, and Rehabilitation*, ASTM STP 901. Philadelphia: American Society for Testing and Materials, 1986.
- DETHIER, JEAN. *Down to Earth: Adobe Architecture*. New York: Facts on File, 1983.
- DEZETTELL, LOUIS, M., *Masons and Builders Library*, Vol. II. New York: Macmillan Publishing Co., 1986.
- DONALDSON, BARRY, ED. *New Stone Technology, Design and Construction for Exterior Wall Systems*, ASTM STP 996. Philadelphia: American Society for Testing and Materials, 1988.
- DRYSDALE, ROBERT, AHMAD HAMID, AND LAWRIE BAKER. *Masonry Structures Behavior and Design*, 2d ed. Boulder, CO: The Masonry Society, 1999.
- DUNCAN, S. BLACKWELL. *The Complete Book of Outdoor Masonry*. Blue Ridge Summit, PA: TAB Books, 1978.
- EGAN, M. DAVID. *Concepts in Building Fire Safety*. New York: John Wiley & Sons, 1978.
- ELMINGER, A. *Architectural and Engineering Concrete Masonry Details for Building Construction*. Herndon, VA: National Concrete Masonry Association, 1976.
- FEININGER, ANDREAS. *Man and Stone*. New York: Crown Publishers, 1961.
- FITCH, JAMES MARSTON. *Historic Preservation*. New York: McGraw-Hill, 1982.
- GLOAG, JOHN. *The Architectural Interpretation of History*. New York: St. Martin's Press, 1975.
- GOODWIN, STANLEY E., AND MARIO J. CATANI. *Simplified Thermal Design of Building Envelopes for Use with ASHRAE Standard 90-75*. Skokie, IL: Portland Cement Association, 1976.
- GRIMM, CLAYFORD T. *Cleaning Masonry—A Review of the Literature*. Arlington, TX: Construction Research Center of the University of Texas at Arlington, 1988.

- GRIMM, CLAYFORD T. *Conventional Masonry Mortar—A Review of the Literature*. Arlington, TX: Construction Research Center of the University of Texas at Arlington, 1994.
- GRIMMER, ANNE E. *Keeping it Clean: Removing Exterior Dirt, Paint, Stains and Graffiti from Historic Masonry Buildings*. Washington, DC: U.S. Dept. of the Interior, National Parks Service, Preservation Assistance Division, Technical Preservation Services, 1988.
- GROGAN, J. C., AND J. T. CONWAY, EDS. *Masonry: Research, Application, and Problems*, ASTM STP 871. Philadelphia: American Society for Testing and Materials, 1985.
- HARRIS, HARRY A., ED. *Masonry: Materials, Design, Construction, and Maintenance*, ASTM STP 992. Philadelphia: American Society for Testing and Materials, 1988.
- HEYMAN, JACQUES. *The Masonry Arch*. New York: John Wiley & Sons, 1982.
- HUFF, DARREL. *How to Work with Concrete and Masonry*. New York: Popular Science Publishing, 1968.
- INDIANA LIMESTONE INSTITUTE. *Indiana Limestone Handbook*, 17th ed. Bedford, IN: ILI.
- INTERNATIONAL CONFERENCE OF BUILDING OFFICIALS. *Uniform Building Code*. Whittier, CA: ICBO, 1991.
- INTERNATIONAL MASONRY INDUSTRY ALL-WEATHER COUNCIL. *Recommended Practices and Guide Specifications for Cold Weather Masonry Construction*. Washington, DC: International Masonry Institute, 1970.
- INTERNATIONAL MASONRY INDUSTRY ALL-WEATHER COUNCIL TECHNICAL TASK COMMITTEE. *All-Weather Masonry Construction State-of-the-Art Report*. Washington, DC: International Masonry Institute, 1968.
- JOHNSON, FRANKLIN B., ED. *Designing, Engineering and Constructing with Masonry Products*. Taken from the *Proceedings of the International Conference on Masonry Structural Systems*, The University of Texas at Austin, 1967. Houston: Gulf Publishing, 1969.
- KREH, R. T., SR. *Masonry Skills*. New York: Van Nostrand Reinhold, 1976.
- LEBA, THEODORE, JR. *Design Manual—The Application of Non-reinforced Concrete Masonry Loadbearing Walls in Multistory Structures*. Herndon, VA: National Concrete Masonry Association, 1969.
- LEONTOVICH, VALERIAN. *Frames and Arches*. New York: McGraw-Hill, 1959.
- LEWIS, MICHAEL. *Modern Stone Cladding*, ASTM Manual 21. Philadelphia: ASTM, 1995.
- LIEFF, M., AND H. R. TRECHSEL, EDS. *Moisture Migration in Buildings*, ASTM STP 779. Philadelphia: American Society for Testing and Materials, 1982.
- LONDON, MARK. *Masonry: How to Care for Old and Historic Brick and Stone*. Washington, DC: The Preservation Press, 1988.
- LOS ALAMOS SCIENTIFIC LABORATORY. *Passive Solar Design Handbook*. Washington, DC: U.S. Dept. of Energy, 1980.
- MACKINTOSH, ALBIN. *Design Manual—The Application of Reinforced Concrete Masonry Loadbearing Walls in Multi-Story Structures*. Herndon, VA: National Concrete Masonry Association, 1973.
- MARS, G. C., ED. *Brickwork in Italy*. Chicago: American Face Brick Association, 1925.

- MASONRY INSTITUTE OF AMERICA. *Masonry Veneer*. Los Angeles: MIA, 1974.
- MASONRY INSTITUTE OF AMERICA. *Reinforcing Steel in Masonry*. Los Angeles: MIA.
- MASONRY STANDARDS JOINT COMMITTEE. *Building Code Requirements for Masonry Structures* (ACI 530/ASCE 5/TMS 402). Detroit: American Concrete Institute, 1992.
- MASONRY STANDARDS JOINT COMMITTEE. *Specifications for Masonry Structures* (ACI 530.1/ASCE 6/TMS 602). Detroit: American Concrete Institute, 1992.
- MATTHYS, JOHN H., ED. *Masonry: Components to Assemblages*, ASTM STP 1063. Philadelphia: American Society for Testing and Materials, 1990.
- MATTHYS, JOHN H., ED. *Masonry Designers' Guide, 3d ed., Based on Building Code Requirements for Masonry Structures* (ACI 530-99/ASCE 5-99/TMS 402-99 and *Specifications for Masonry Structures* (ACI 530.1-99/ASCE 6-99/TMS 602-99)). The Masonry Society, 2001.
- MAZRIA, EDWARD. *The Passive Solar Energy Book*. Emmaus, PA: Rodale Press, 1979.
- MCHEMRY, PAUL GRAHAM, JR. *Adobe and Rammed Earth Buildings: Design and Construction*. New York: John Wiley & Sons, 1984.
- MCKEE, HARLEY J. *Introduction to Early American Masonry—Stone, Brick, Mortar and Plaster*. Washington, DC: The Preservation Press, 1973.
- MCLAUGHLIN, JACK. *Jefferson and Monticello: The Biography of a Builder*. New York: Henry Holt, 1988.
- MCRAVEN, CHARLES. *Building with Stone*. Pownal, VT: Storey Communications, 1989.
- NASHED, FRED. *Time Saver Details for Exterior Wall Design*. New York: McGraw-Hill, 1996.
- NATIONAL BUREAU OF STANDARDS. *Fire-Resistance Classifications of Building Construction*, Report BMS 92. Washington, DC: U.S. Government Printing Office, 1942.
- NATIONAL BUREAU OF STANDARDS. *Fire-Resistance of Structural Clay Tile Partitions*, Report BMS 113. Washington, DC: U.S. Government Printing Office, 1948.
- NATIONAL BUREAU OF STANDARDS. *Fire Tests of Brick Walls*, Report BMS 143. Washington, DC: U.S. Government Printing Office, 1954.
- NATIONAL CODES AND STANDARDS COUNCIL OF THE CONCRETE AND MASONRY INDUSTRIES. *Thermal Mass Handbook: Concrete and Masonry Design Provisions Using ASHRAE/IES 90.1-1989*. Herndon, VA: NCMA, 1995.
- NATIONAL CONCRETE MASONRY ASSOCIATION. *Design Manual for Segmental Retaining Walls (Modular Concrete Block Retaining Wall Systems)*. Simac, Michael R., et al., Herndon, VA: NCMA, 1993.
- NATIONAL CONCRETE MASONRY ASSOCIATION. *TEK Bulletins*, nos. 1-164. Herndon, VA: NCMA.
- NATIONAL FIRE PROTECTION ASSOCIATION. *Fire Protection Handbook*, 17th ed. Quincy, MA: NFPA, 1991.
- NATIONAL FIRE PROTECTION ASSOCIATION. *Life Safety Code Handbook*. Quincy, MA: NFPA, 1991.
- NATIONAL LIME ASSOCIATION. *Masonry Mortar Technical Notes Series*. Arlington, VA: NLA.

- NATIONAL PARK SERVICE, U.S. Dept. of the Interior. *Preservation Briefs*, nos. 1–23. Washington, DC: U.S. Government Printing Office.
- NEWMAN, MORTON. *Structural Details for Masonry Construction*. New York: McGraw-Hill, 1986.
- O'BRIEN, JAMES J. *Construction Inspection Handbook*, 3d ed. New York: John Wiley & Sons, 1991.
- O'CONNOR, THOMAS F., ED. *Building Sealants: Materials, Properties and Performance*. ASTM STP 1069. Philadelphia: American Society for Testing and Materials, 1990.
- O'NEILL, HUGH. *Stone for Building*. London: William Heinemann, 1965.
- OLGYAY, ALADAR AND VICTOR. *Solar Control and Shading Devices*. Princeton, NJ: Princeton University Press, 1957.
- OLGYAY, VICTOR. *Design with Climate*. Princeton, NJ: Princeton University Press, 1963.
- ONTARIO MINISTRY OF CITIZENSHIP AND CULTURE. *Annotated Master Specifications for the Cleaning and Repointing of Historic Masonry*. Toronto: Heritage Branch of the Ontario Ministry of Citizenship and Culture, 1985.
- PATTERSON, TERRY L., *Illustrated 2000 Building Code Handbook*, New York: McGraw-Hill, 2001.
- PAULAY, TOM, AND M. J. N. PRIESTLY. *Seismic Design of Reinforced Concrete and Masonry Buildings*. New York: John Wiley & Sons, 1992.
- PLUMMER, HARRY C. *Brick and Tile Engineering*. Reston, VA: Brick Institute of America, 1962.
- Proceedings: Third Canadian Masonry Symposium*, The University of Alberta at Edmonton, 1983.
- Proceedings: Fourth Canadian Masonry Symposium*, The University of New Brunswick at Fredericton, 1986.
- Proceedings: Fifth Canadian Masonry Symposium*, The University of British Columbia at Vancouver, 1989.
- Proceedings: Second North American Masonry Conference*, University of Maryland. Boulder, CO: The Masonry Society, 1982.
- Proceedings: Third North American Masonry Conference*, University of Texas at Arlington. Boulder, CO: The Masonry Society, 1985.
- Proceedings: Fourth North American Masonry Conference*, University of California at Los Angeles. Boulder, CO: The Masonry Society, 1988.
- Proceedings: Fifth North American Masonry Conference*, University of Illinois at Urbana-Champaign. Boulder, CO: The Masonry Society, 1991.
- PRZETAK, LOUIS. *Standard Details for Fire-Resistive Building Construction*. New York: McGraw-Hill, 1977.
- QUIROUETTE, R. L. *The Difference Between a Vapor Barrier and an Air Barrier*. Ottawa, Ontario: National Research Council of Canada, 1985.
- RAMSEY, CHARLES G., AND HAROLD S. SLEEPER. *Architectural Graphic Standards*, 6th ed. New York: John Wiley & Sons, 1970.
- RAMSEY, CHARLES G., AND HAROLD S. SLEEPER. *Architectural Graphic Standards*, 8th ed. New York: John Wiley & Sons, 1988.
- RANDALL, FRANK A., AND WILLIAM C. PANARESE. *Concrete Masonry Handbook*, 5th ed. Skokie, IL: Portland Cement Association, 1991.

- REDSTONE, LOUIS G. *Masonry in Architecture*. New York: McGraw-Hill, 1984.
- RITCHIE, THOMAS, AND J. IVAN DAVISON. *Cement-Lime Mortars*. Ottawa, Ontario: National Research Council, Division of Building Research, 1964.
- SAHLIN, SVEN. *Structural Masonry*. Englewood Cliffs, NJ: Prentice Hall, 1970.
- SCHEFFLER, MICHAEL J., IAN R. CHIN, AND DEBORAH SLATON. *Moisture Expansion of Fired Bricks in Proceedings 5NAMC*, June 1990, vol. II, pp. 549–562.
- SCHNEIDER, ROBERT R., AND WALTER L. DICKEY. *Reinforced Masonry Design*, 2d ed. Englewood Cliffs, NJ: Prentice Hall, 1989.
- SCHWARTZ, THOMAS A., ED. *Water in Exterior Building Walls: Problems and Solutions*, ASTM STP 1107. Philadelphia: American Society for Testing and Materials, 1991.
- SMITH, BAIRD M. *Moisture Problems in Historic Masonry Walls: Diagnosis and Treatment*. Washington, DC: U.S. Dept. of the Interior, National Park Service, Preservation Assistance Division, 1984.
- SOLES, EARL L., JR. *The Colonial Williamsburg Historic Trades Annual*, vol. II. Williamsburg, VA: The Colonial Williamsburg Foundation, 1990.
- SOUTHERN BUILDING CODE CONGRESS. *Standard Building Code*. Birmingham, AL: SBCC, 1991.
- STAHL, FREDERICK S. *A Guide to the Maintenance, Repair, and Alteration of Historic Buildings*. New York: Van Nostrand Reinhold, 1984.
- STOKOE, JAMES. *Decorative and Ornamental Brickwork*. New York: Dover Publications, 1982.
- SZOKOLAY, S. V. *Solar Energy and Building*. London: The Architectural Press, 1975.
- THE UNDERGROUND SPACE CENTER, University of Minnesota. *Earth Sheltered Housing Design*. New York: Van Nostrand Reinhold, 1978.
- TOBIASSON, WAYNE, "Vapor Retarders to Control Summer Condensation," *Proceedings of the ASHRAE/DOE/BTECC Conference on Thermal Performance of the Exterior Envelope of Buildings IV*, Orlando, Fla., 1989.
- TOBIASSON, WAYNE, AND MARCUS HARRINGTON, "Vapor Drive Maps of the U.S.," *Proceedings of the ASHRAE/DOE/BTECC Conference on Thermal Performance of the Exterior Envelope of Buildings III*, Clearwater Beach, Fla., 1985.
- TRECHSEL, HEINZ R., AND MARK BOMBERG, EDs. *Water Vapor Transmission Through Building Materials and Systems: Mechanisms and Measurement*, ASTM STP 1039. Philadelphia: American Society for Testing and Materials, 1989.
- WATSON, DONALD, ED. *Energy Conservation Through Building Design*. New York: McGraw-Hill, 1979.
- WOODFORDE, JOHN. *Bricks to Build a House*. London: Routledge & Kegan Paul, 1976.

This page intentionally left blank.

INDEX

This page intentionally left blank.

A

- Acoustical characteristics, 77, 103, 224
 - noise reduction coefficient (NRC), 225–227
 - sound absorption coefficient (SAC) 225–226
 - sound transmission class (STC), 225, 228–232, 233
 - sound transmission loss (STL), 225, 228–229
- Actual dimensions, 61
- Adhered veneer, 184, 326, 328
- Admixtures, 22, 32, 33, 36–37, 558–559
- Adobe, 78–81
- Aggregates, 20, 30, 39, 88, 103–104, 194, 468, 552, 557–559, 573
- Air entrainment, 27, 28, 29, 34
- Allowable stress design, 395, 405–410
- Analytical design, 316–317, 395, 396, 399, 405–418
- Anchor bolts, 162, 164
- Anchored veneer, 244, 245, 328–358
- Anchors, 159–162, 242–246, 329, 330, 333, 519, 559–560
- Arches, 4, 368–378, 484, 486, 488, 510, 515
- Arching action, 360–363
- ASTM A82, 147, 148, 159, 559, 573
- ASTM A153, 149, 150, 151, 154, 158, 311, 559, 573
- ASTM A167, 148, 150, 155, 158, 162, 573
- ASTM A185, 159, 573
- ASTM A615, 560, 573
- ASTM A616, 573
- ASTM A617, 573
- ASTM A641, 149, 150, 151, 154
- ASTM A951, 154, 559, 573
- ASTM C5, 558
- ASTM C32, 61
- ASTM C33, 20, 85, 87, 557
- ASTM C34, 64
- ASTM C55, 83, 103, 557–558, 574
- ASTM C56, 64–65
- ASTM C62, 43, 44, 45, 47, 73, 421, 555, 556, 573
- ASTM C67, 531, 533, 555, 556, 578
- ASTM C73, 84, 103
- ASTM C90, 88, 89, 103, 366, 421, 517, 557, 574
- ASTM C91, 29, 126, 558, 573
- ASTM C97, 107
- ASTM C126, 44, 55, 64, 66, 72, 73, 77, 556
- ASTM C129, 88, 103, 294, 517, 557, 574
- ASTM C140, 557–558
- ASTM C144 30–32, 449, 558, 573
- ASTM C150, 558, 572
- ASTM C170, 107
- ASTM C199, 143
- ASTM C207, 28, 131, 558, 573
- ASTM C212, 64, 66, 77
- ASTM C216, 44, 45, 46, 47, 55, 64, 73, 279, 294, 421, 516, 554, 556, 573
- ASTM C241, 107
- ASTM C270, 32, 34, 127, 137–138, 139, 140–142, 364, 366, 411–412, 421, 542, 558–561, 565, 573–574
- ASTM C279, 61
- ASTM C315, 455
- ASTM C331, 21, 87, 557
- ASTM C404, 30, 143–144, 558, 573
- ASTM C410, 60
- ASTM C476, 143–144, 145, 366, 411–412, 421, 558, 573
- ASTM C503, 117
- ASTM C530, 70, 71, 294
- ASTM C568, 115
- ASTM C615, 113
- ASTM C616, 118
- ASTM C629, 117
- ASTM C652, 44, 45, 47, 54, 66, 73, 421, 556, 573
- ASTM C744, 94, 99
- ASTM C780, 142, 412, 558, 560, 574
- ASTM C880, 107
- ASTM C901, 578
- ASTM C902, 56, 58, 453
- ASTM C936, 97, 452
- ASTM C952, 129
- ASTM C1019, 146, 412, 560, 574
- ASTM C1072, 129
- ASTM C1093, 554
- ASTM C1142, 470, 559, 560
- ASTM C1242, 162, 340
- ASTM C1261, 57, 60
- ASTM C1272, 57, 59, 453
- ASTM C1283, 455
- ASTM C1314, 412, 560–561, 575

- ASTM C1319, 97, 453
 ASTM C1324, 142, 541
 ASTM C1329, 29, 30, 135–136, 558, 573
 ASTM C1357, 129
 ASTM C1364, 86
 ASTM C1372, 421
 ASTM C1384, 33
 ASTM C1386, 87
 ASTM C1400, 533
 ASTM C1405, 44, 55, 73, 556, 573
 ASTM C1452, 87
 ASTM C1472, 247, 252, 518
 ASTM E72, 129
 ASTM E488, 164
 ASTM E518, 129
 ASTM E1857, 528
 ASTM E2260, 541
 Autoclaved aerated concrete (AAC), 87, 88
 Autogenous healing, 28, 133
 Axial load distribution, 379–381, 382
- B**
- Beams, 389–391
 Bond:
 beams, 253, 256
 masonry unit, 180, 182, 294, 299, 322, 324,
 401, 402, 404, 407, 432, 484, 479, 480,
 481, 484, 485–486
 mortar, 127–129, 134
 patterns, 220, 297, 299, 304, 454, 455
 stack, 46, 70, 219, 296, 309, 379, 406, 516,
 517, 554, 570
 strength, 127–129
 Bracing, 509–510, 513, 514, 515, 574
 Brick:
 calcium silicate, 83–84
 clinker, 12, 18, 49
 fire, 54–55
 glazed, 17, 55–56, 556
 grade, 43, 45, 46, 54, 55, 61
 hollow, 52, 53–54
 initial rate of absorption, 75, 76, 126, 128,
 138, 279, 472–473, 523, 578, 580
 paving, 56–57, 58–59, 445–454, 456, 457
 refractory, 54, 60
 salmon, 11, 12, 18, 46, 49, 76
 type, 45, 46, 54, 55, 56, 57, 60, 61, 516–517,
 554
- C**
- Calcium carbonate stains, 131, 135, 511, 530,
 533–534, 537
 Calcium chloride, 22, 34, 149, 522, 564, 573
 Calcium silicate brick, 83–84
 Carbonation, 133, 135
 Cast stone, 85–86, 87, 346, 364, 563
 Cavity walls, 180, 182–184, 185, 322–323,
 324–326, 327, 382, 406
 Cellular concrete (see Autoclaved aerated
 concrete)
- Chimneys, 265, 274, 454–456, 459, 462, 463
 Cleaning, 527–539, 582
 Clinker brick, 12, 18, 49
 Coatings, 22, 38–39, 49, 87, 183, 286–290,
 430, 566
 Cold weather construction, 521–523
 Composite walls, 177, 179, 180, 183, 184,
 322–324, 325, 381, 382, 400, 406
 Concrete masonry units, 20–26, 83–104
 calcium silicate brick, 83–84
 concrete block, 87–104
 concrete brick, 83–84
 paving, 96, 100, 101, 445–454, 455
 prefaced, 93–94, 99
 sand-lime brick, 83–84
 screen block, 93, 97, 98, 220
 segmental retaining walls, 97, 102, 421,
 435–439
 slump block, 23
 Condensation, 182–183, 201, 213, 216, 218,
 283–286, 287, 428, 532
 Connectors, 147, 156, 326
 anchors, 159–163, 242–246, 329, 330, 333,
 502, 519, 559–560
 fasteners, 164–166, 334, 573
 ties, 34, 90, 147, 149, 151, 153–154,
 156–159, 180, 182, 299, 322–324, 326,
 328, 346, 400–401, 405, 408, 413, 424,
 432, 473, 479, 484, 496, 502, 523,
 559–560, 564, 566, 572–573, 578–582
 Construction tolerances, 46, 57, 66, 86, 94,
 116–117, 137, 155, 247, 250–251, 258,
 263, 266, 340, 490, 498, 513–521,
 552–557, 559, 567, 574–575, 579–580
 Control joints, 166, 167, 239, 246–248,
 250–254, 255–259, 339, 421, 493, 496,
 500, 501, 518
 Coping, 263, 273–275, 280–282, 302, 312,
 343, 346
 Corbeling, 334, 405, 410
 Corrosion protection, 147–152, 153, 502,
 573
 Coursing, 49, 474, 478–479
 Curing, 128, 135, 273, 413, 524–525, 543,
 574, 582
 Curtain walls, 177, 180, 184, 312–314, 350,
 570
- D**
- Dampproofing, 183, 282–283, 325
 (See also Waterproofing)
 Deflection, 240, 242, 309, 314, 328, 331, 348,
 359, 383, 390, 518–519
 Design:
 analytical, 316–317, 395, 396, 399,
 405–418
 empirical, 7–8, 291, 313–314, 399–405,
 410
 strength, 395, 399, 410, 572
 Differential movement, 153, 235, 240–242,
 273, 317, 323–324, 328, 343, 346, 348,
 349, 412–414

Dimensions:

- actual, 61
- nominal, 49, 62, 66, 90, 400, 406, 454, 572
- Drainage accessories, 173
- Drainage walls, 10, 260–270, 333, 582–583

E

- Efflorescence, 131, 259, 285–286, 288, 290, 468, 492, 511, 522, 530–533, 534, 555–556
- Empirical design, 7–8, 291, 313–314, 399–405, 410
- Environmental impact, 37–39
- Equivalent thickness, 193–194
- Expansion joints, 76, 166, 232, 235, 240–242, 246–247, 249–262, 276, 346, 451, 493, 495–496, 501, 566

F

- Fasteners, 164–166, 334, 573
- FBA brick, 46, 516–517, 554
- FBS brick, 46, 516–517, 554
- FBX brick, 46, 516–517, 554
- Fences, 294, 297, 299–312, 313, 314
- Field observation, 553–554, 579–580, 582–583
(See also Inspection)
- Fire brick, 54–55
- Fire insurance rates, 199
- Fire resistance, 21, 63, 77, 84, 103, 144, 186–199
- Fireplaces, 57, 142–143, 454–456, 458–462
- Flagstone, 110–111, 113, 118
- Flashing, 10, 92, 167–170, 178, 182, 241, 260–276, 280–281, 288, 290, 302, 319, 321, 324–325, 331, 334, 343, 346, 348–350, 363, 456, 467–468, 490, 492, 493, 494–495, 496, 497, 518–519, 563, 566–567, 572, 575
- Flexible anchorage, 242–246, 328
- Footings, 297, 299, 301–302, 307, 310, 311, 421, 427–428, 430–433
- Foundation walls, 91, 392, 401, 421, 423–429, 430, 431, 432, 434, 435
- Foundations, 138, 241, 251, 297, 299, 334, 392, 401, 419–436, 437

G

- Gaudi, Antonio, 5, 7
- Glass block, 61–62, 63, 180, 219, 309–311, 315, 316, 317, 318, 319
- Glazed brick, 55–56, 556
- Granite, 112–113, 115
- Grout, 26–28, 30, 34, 36–37, 143–146, 558–559
- Grouting, 498–501, 503–509, 510, 511–512, 520, 568, 574, 581–582

H

- h/t* ratios, 291, 292, 294, 312–313
- Headers, 180, 299, 324, 401, 484, 486
- Hot weather construction, 34, 133, 523–525
- Hysteresis, 120

I

- Initial rate of absorption, 75, 76, 126, 128, 138, 279, 472–473, 523, 578, 580
- Inspection, 406, 506, 549, 551–554, 565, 567, 576, 579–581
(See also Field observation)
- Insulation, 153, 183, 207, 211–218, 328, 484

J

- Joint reinforcement, 152–156, 239–240, 247, 253–254, 257–258, 296–297, 299, 310–311, 323–324, 334, 339, 346, 379, 399, 401, 404, 405–406, 408–409, 414, 424–425, 493, 496, 500, 501, 502, 559, 573
- Joints:
 - control, 166, 167, 239, 246–248, 250–254, 255–259, 339, 421, 493, 496, 500, 501, 518
 - expansion, 76, 166, 232, 235, 240–242, 246–247, 249–262, 276, 346, 451, 493, 495–496, 501, 566
 - mortar, 10, 49, 129, 271, 273, 277, 278, 281, 287, 319, 323, 346, 467, 479, 486–490, 491, 492, 517–518, 532–533, 540–543, 544, 575, 581
 - sealant, 237, 247–251, 258–259, 268, 273, 275–276, 286, 340, 346, 348, 493, 495–496, 517–518

L

- Lateral support, 291–294, 297, 312, 314, 399–401, 423–425, 495
- Lime, 27–29, 101, 123, 126, 128–134, 136–141, 281, 469–470, 524, 531, 533, 541–542, 558, 573
- Limestone, 114–116, 121
- Limit states design (see Design, strength)
- Lintels, 148, 328, 334, 359–368, 559, 563, 570, 580–581
- Loadbearing walls, 5, 8, 178–180, 181, 246, 322–325, 379–385, 393, 395, 413, 572

M

- Manganese stains, 528, 534–535
- Marble, 116–117
- Masonry cement, 29, 33, 36, 125–126, 130, 133–137, 533, 558, 573
- Masonry unit bond, 180, 182, 294, 299, 322, 324, 401, 402, 404, 407, 432, 479, 480, 481, 484, 485–486

- Minimum wall thickness, 399, 424, 427
- Mock-ups, 566–568, 575
- Modular coordination, 50–51, 66, 474–478, 485, 570, 572
- Moist curing (see Curing)
- Moisture:
- control, 10, 30, 35, 91–92, 127–128, 136–137, 167, 170–173, 177–178, 182, 184, 213, 215, 242, 247, 259–290, 317, 319, 320, 324–327, 331–339, 344–349, 428, 467–468, 479, 484, 488, 490–500, 533, 540, 581, 582
 - expansion, 76, 166, 231, 237, 239–242, 247, 302, 323–324, 346, 413, 430, 495
 - shrinkage, 101–103, 130, 166, 231, 237, 239, 247, 323–324, 493, 525
 - vapor, 35, 185, 213, 217–218, 259, 283–290, 428, 532, 533, 541
- (See also Condensation)
- Mortar:
- bond, 127–129, 134
 - cement, 29, 126, 135–136, 558, 573
 - joints, 10, 49, 129, 271, 273, 277, 278, 281, 287, 319, 323, 346, 467, 479, 486–490, 491, 492, 517–518, 532–533, 540–543, 544, 575, 581
 - mixes, 124, 144, 412, 469, 471, 472, 542, 543, 582
 - placement, 479, 481–484
 - pointing, 138, 489, 541–543
 - retempering, 28, 34, 125, 127, 138, 471, 524, 580
 - slump, 126, 144, 146, 470
 - testing, 141–142, 560, 574
 - tuckpointing, 138, 541, 543
 - type, 137–141, 271, 558–559, 561, 573
- Multi-wythe walls, 9, 153, 177, 178, 180, 182–185, 212, 242, 322–346, 381, 401, 504
- N
- Noise reduction coefficient (NRC), 225–227
- Nominal dimensions, 49, 62, 66, 90, 400, 406, 454, 572
- Non-loadbearing walls, 8, 178, 180, 291–294, 309, 322, 326, 384, 385, 387, 555
- P
- Parapets, 241–242, 251, 253, 263, 273, 280–281, 283, 341, 343–348, 349, 350, 351–353, 400, 566
- Partition walls, 292–295
- Passive solar design, 38, 206–211, 212, 218–224
- Paving:
- brick, 56–57, 58–59, 445–454, 456, 457
 - concrete masonry, 96–97, 100, 101, 445–454, 455
- Pilasters, 321, 400, 402, 424, 426–427, 478, 480
- Pointing, 138, 489, 541–543
- Prefabricated masonry, 368, 513, 516, 578
- Prism test, 411–412, 560–561, 565, 574–575
- Q
- Quality assurance, 547–551, 554, 561, 564, 566, 572, 577
- Quality control, 34, 468, 513, 547–548, 551–554, 561, 564–565, 572, 574
- R
- Rainscreen wall, 261–263
- Refractory brick, 54, 60
- Refractory mortar, 55, 57, 142–143
- Reinforced masonry, 5, 8, 87, 90, 100, 144, 166, 184, 197, 239, 247, 253, 257, 292, 294, 297, 299, 334, 346, 359, 364, 367, 379, 384, 386, 390, 392–399, 403, 406, 413–414, 423, 496–500, 503, 504, 505, 506, 507, 508, 520, 560, 581
- Retaining walls, 97, 419–421, 429–444
- Retempering, 28, 34, 125, 127, 138, 471, 524, 580
- Rubble stone, 4, 85, 110, 113, 119, 307, 339
- S
- Sailor, 484
- Salmon brick, 11, 12, 18, 46, 49, 76
- Sample panel, 486, 545, 555–557, 564, 566, 575–576
- Sampling and testing, 72, 78, 141–142, 146, 411–412, 531, 555, 557–558, 560–561, 565, 574–575, 578
- Sandstone, 105–106, 108, 112, 118–119
- Screen block, 93, 97, 98, 220
- Screen tile, 70–71, 220, 296
- Screen walls, 10, 220, 294, 295–297, 298, 299, 301
- Sealant joints, 237, 247–251, 258–259, 268, 273, 275–276, 286, 340, 346, 348, 493, 495–496, 517–518
- Segmental retaining walls, 97, 421, 435–439
- Seismic requirements, 153, 162, 243, 328, 385, 400, 414–418, 456, 478
- Serpentine walls, 299, 301, 309
- Shear walls, 381, 383–389, 391, 393, 400, 405, 406, 414, 418, 478
- Shelf angles, 148, 185, 240, 242, 258, 261, 263, 312, 317, 326, 328, 348–350, 354–358, 491, 498, 513, 518–519, 559, 566, 570, 575, 580
- Single-wythe walls, 9, 51, 177, 178, 179, 180, 181, 194, 216, 260, 263, 265, 266, 290, 292, 294, 309, 312, 313, 317, 319–322, 324, 400, 413, 488, 504, 506, 570
- Slate, 105, 112, 117–118
- Slump, 126, 144, 146, 470
- Solar (see Passive solar design)
- Soldier, 449, 484
- Sound absorption coefficient (SAC), 225–226
- Sound transmission class (STC), 225, 228–232, 233
- Sound transmission loss (STL), 225, 228–229

- Spalling, 12, 66, 97, 240, 242, 247, 290, 387, 454, 481, 519, 522, 533, 540
- Stack bond, 46, 70, 219, 296, 309, 379, 406, 516, 517, 554, 570
- Strength design, 395, 399, 410, 572
- Structural clay tile, 62–64
- facing, 66
 - glazed, 66–70
 - loadbearing, 64, 67
 - non-loadbearing, 64–65
 - screen, 70–71, 220, 296
- Submittals, 411, 548–554, 561–566, 574, 576–577
- T
- Terra cotta, 11, 43, 64, 70–72, 138, 184, 326, 495, 537, 543
- Thermal expansion, 76, 103, 120, 235–237, 238, 247, 268, 305, 341, 413, 490, 493, 495, 522
- Ties, 34, 90, 147, 149, 151, 153–154, 156–159, 180, 182, 299, 322–324, 326, 328, 346, 400–401, 405, 408, 413, 424, 432, 473, 479, 484, 496, 502, 523, 559–560, 564, 566, 572–573, 578–582
- Tolerances, 46, 57, 66, 86, 94, 116–117, 137, 155, 247, 250–251, 258, 263, 266, 340, 490, 498, 513–521, 552–557, 559, 567, 574–575, 579–580
- Travertine, 105, 108, 116–117
- Tuckpointing, 138, 541, 543
- U
- UL ratings, 196
- Used brick, 46, 49, 454
- V
- Value engineering, 571
- Vanadium stains, 534
- Vapor (see Moisture, vapor)
- Veneer, 8, 9, 70–72, 106, 108, 110–113, 116–121, 129, 138, 156, 159–160, 162, 177, 178, 184–186, 201, 240, 242–243, 251, 260–261, 278, 317, 326, 328–341, 342, 346, 348–350, 363, 484, 517–519, 560
- W
- Walls:
- barrier, 10, 262
- Walls (Cont.):
- cavity, 180, 182–184, 185, 322–323, 324–326, 327, 382, 406
 - composite, 177, 179, 180, 183, 184, 322–324, 325, 381, 382, 400, 406
 - curtain, 177, 180, 184, 312–314, 350, 570
 - drainage, 10, 260–270, 333, 582–583
 - garden, 294, 296–309, 310, 311
 - loadbearing, 5, 8, 178–180, 181, 246, 322–325, 379–385, 393, 395, 413, 572
 - multi-wythe, 9, 153, 177, 178, 180, 182–185, 212, 242, 322–346, 381, 401, 504
 - non-loadbearing, 8, 178, 180, 291–294, 309, 322, 326, 384, 385, 387, 555
 - parapet, 241–242, 251, 253, 263, 273, 280–281, 283, 341, 343–348, 349, 350, 351–353, 400, 566
 - partition, 292–295
 - rainscreen, 261–263
 - retaining, 97, 419–421, 429–444
 - screen, 10, 220, 294, 295–297, 298, 299, 301
 - segmental retaining, 97, 421, 435–439
 - serpentine, 299, 301, 309
 - shear, 381, 383–389, 391, 393, 400, 405, 406, 414, 418, 478
 - single-wythe, 9, 51, 177, 178, 179, 180, 181, 194, 216, 260, 263, 265, 266, 290, 292, 294, 309, 312, 313, 317, 319–322, 324, 400, 413, 488, 504, 506, 570
 - veneer, 8, 9, 70–72, 106, 108, 110–113, 116–121, 129, 138, 156, 159–160, 162, 177, 178, 184–186, 201, 240, 242–243, 251, 260–261, 278, 317, 326, 328–341, 342, 346, 348–350, 363, 484, 517–519, 560
- Water repellents, 22, 35, 91, 101–102, 116, 289–290, 319, 321, 533, 537, 539, 566, 582
- Waterproofing, 282–283, 289, 290, 428, 430, 434, 435
(See also Dampproofing).
- Weep holes, 10, 137, 170–171, 173, 178, 215–216, 260–263, 270, 278, 288, 319–321, 324–326, 334, 348, 350, 421, 430, 432–434, 437, 467–468, 484, 489, 490–493, 498, 499, 533, 566, 578–583
- Wind loads, 242, 274, 291, 297, 299, 301, 312, 316, 322, 328, 331, 341, 343, 381, 399–400, 410, 413, 414, 427, 478, 487, 493, 509–510, 523

This page intentionally left blank.

ABOUT THE AUTHOR

Christine Beall has more than 25 years' experience in the design, specification and construction of a broad range of building types. A resident of Austin, Texas, she is a specialist in loadbearing and veneer masonry systems, stucco and EIFS cladding systems, joint sealants, building envelope mold and moisture problems, and vapor condensation analysis.

This page intentionally left blank.

This page intentionally left blank.

This page intentionally left blank.

This page intentionally left blank.

This page intentionally left blank.